

EL 16

ASSEMBLY INSTRUCTION

1. Remove lockers from boxes
2. Attach garment bar holders as shown with provided hardware.
Type A - is mounted to the horizontal section using the holes at the bottom edge on each side.
Type B - is mounted to the vertical locker sections at a position approximately 15 inches below the top. Note: Garment bar hardware needs to be mounted on the right side of one vertical section and the left side of the other vertical section.



Type A



Type B

3. Mark locations for drilled holes as follows.

15" deep lockers – Mark 2 locations 4" from the top and at 3" and 12" from the front. These locations will need to be marked on the inner sides of the two vertical lockers and both ends of the horizontal locker. All holes should now be aligned for assembly.

18" deep lockers – Mark 2 locations 4" from the top and at 3" and 15" from the front. These locations will need to be marked on the inner sides of the vertical lockers and both ends of the horizontal locker. All holes should now be aligned for assembly.

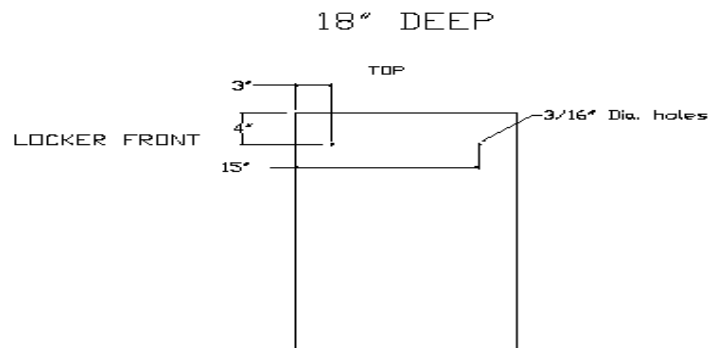
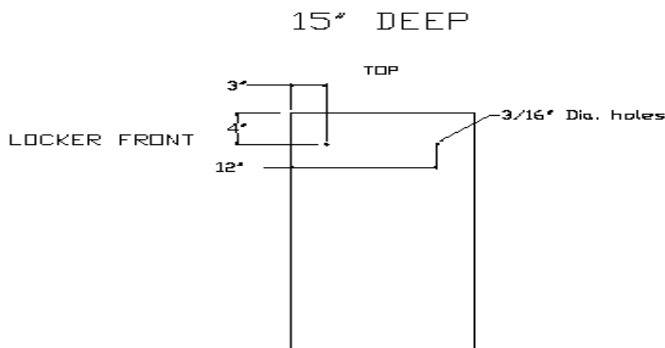

- 4. With 3/16" drill bit, Drill holes at the locations marked.**



- 5. Position locker sections as on their back sides and configure lockers as they will be after assembly. Place garment rod between garment rod holders. Fasten locker sections together using the hardware provided in the EL/Hardware kit.**

