

CONVECTION OVEN

C O N C E P T

COUNTERTOP CONVECTION OVENS

From pastries to entrees...Bakes fast and evenly, intensifies and seals in flavor

- Stainless steel exterior and interior construction
- Rear fan and heater assembly creates true convection pattern
- Unique air flow design ensures quick and uniform baking
- 450°F thermostat and 120 minute timer
- Safety glass door with handle
- Compact footprint
- Insulated exterior and door: FC-33/34/280/280V

WINDSTAR

FC-26 /1
120 V



FC-26
208/240 V

CAPACITY: 2 wire racks and 1 bake tray included;
4 bake trays (optional)
3 quarter size sheet pans (not included)

WINDSTAR

FC-280/1
120 V



FC-280
208/240 V

CAPACITY: 2 wire racks and 1 bake tray included;
4 bake trays (optional)
3 quarter size sheet pans (not included)

BRIZA-V

FC-280V/1
120 V

FC-280V
208/240 V



CAPACITY:

3 slotted shelves and 1 drip pan included
2 additional slotted shelves (optional)
3 quarter size sheet pans (not included)

SIROCCO

FC-34/1
120 V



FC-34
208/240 V

CAPACITY: 3 wire racks and 1 drip pan included
4 bake trays (optional)
3 quarter size sheet pans (not included)

TEMPEST

FC-33/1
120 V



*TurboQuartz feature



FC-33
208/240 V

Convection oven/broiler

All features of FC-34 with two quartz heating elements overhead - convection and broiling modes operate separately

CAPACITY: Same as FC-34 series



100 NIAN TIC AVENUE; SUITE 104 PROVIDENCE, RI 02907
TEL: (401)273-3300 FAX: (401)273-3328 E-mail: sales@equipex.com
www.equipex.com





CONVECTION OVEN/BROILER

FC-33/1 All features of FC-34 with two quartz heating elements overhead
FC-33 - convection and broiling modes operate separately

CONVECTION OVENS

FC-26, FC-26/1, FC-34, FC-34/1

FC-280V, FC-280V/1

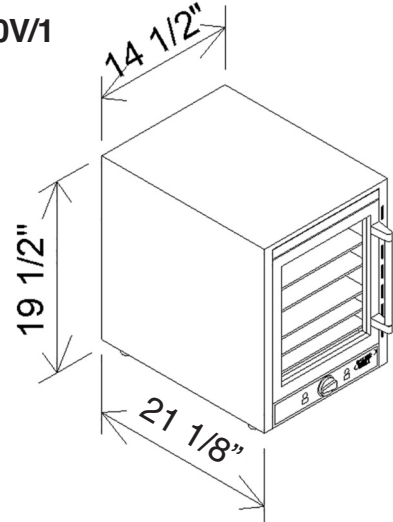
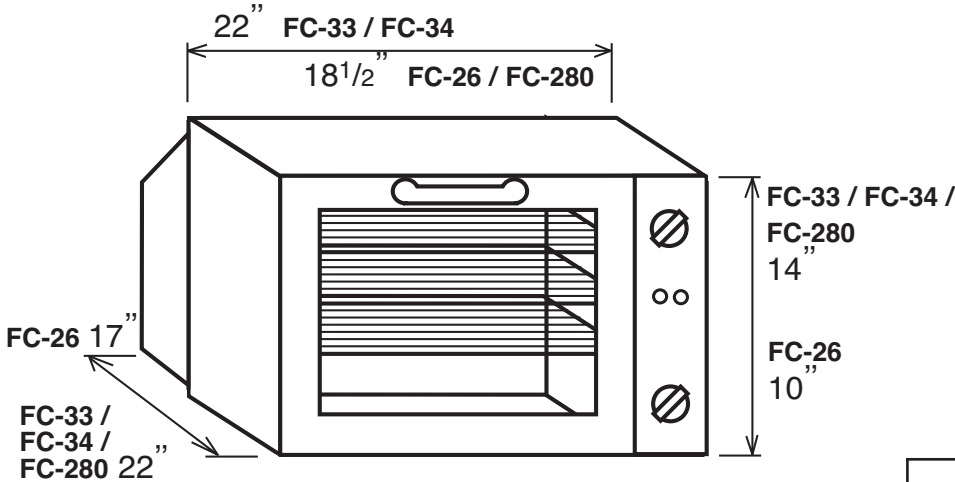

INSTALLATION CLEARANCE: 2" EACH SIDE, TOP AND 3" AT BACK

SPECIFICATIONS

MODEL	SHELF SIZE (WxD)
FC-26 SERIES	12 1/2" x 11 1/2"
FC-33/34 SERIES	14 1/2" x 11 3/4"
FC-280 SERIES	12 1/4" x 12"
FC-280V SERIES	10" x 12"

MODEL	ELECTRICAL	EXTERIOR DIMENSIONS	INTERIOR DIMENSIONS	SHIPPING WEIGHT	NEMA
FC-26	208/240V, 1PH, 2KW, 7/9 Amps	18 1/2"Wx17"Dx10"H	14"Wx12"Dx9"H	35 lbs	6-15 P
FC-26/1	120V, 1.7KW, 15 Amps	18 1/2"Wx17"Dx10"H	14"Wx12"Dx9"H	35 lbs	5-15 P
FC-33	208/240V, 1PH, 3KW, 13/15 Amps	22"Wx22"Dx14"H	16 3/8"Wx13 3/4"Dx10 3/8"H	45 lbs	6-15 P
FC-33/1	120V, 1.7KW, 15 Amps	22"Wx22"Dx14"H	16 3/8"Wx13 3/4"Dx10 3/8"H	45 lbs	5-15 P
FC-34	208/240V, 1PH, 3KW, 13/15 Amps	22"Wx22"Dx14"H	16 3/8"Wx13 3/4"Dx10 3/8"H	45 lbs	6-15 P
FC-34/1	120V, 1.7KW, 15 Amps	22"Wx22"Dx14"H	16 3/8"Wx13 3/4"Dx10 3/8"H	45 lbs	5-15 P
FC-280	208/240V, 1PH, 2KW, 7/9 Amps	18 1/2"Wx22"Dx14"H	12 3/8"W x 12 3/8"D x 10 3/8"H	44 lbs	6-15 P
FC-280/1	120V, 1.7KW, 15 Amps	18 1/2"Wx22"Dx14"H	12 3/8"W x 12 3/8"D x 10 3/8"H	44 lbs	5-15 P
FC-280V	208/240V, 1PH, 2KW, 7/9 Amps	14 1/2"Wx21 1/8"Dx19 1/2"H	10 1/4"Wx12 5/8"Dx13"H	44 lbs	6-15 P
FC-280V/1	120V, 1.7KW, 15 Amps	14 1/2"Wx21 1/8"Dx19 1/2"H	10 1/4"Wx12 5/8"Dx13"H	44 lbs	5-15 P

WARRANTY: Limited one year parts and labor



100 NIAN TIC AVENUE; SUITE 104 PROVIDENCE, RI 02907
 TEL: (401)273-3300 FAX: (401)273-3328 E-mail: sales@equipex.com
 www.equipex.com

