



Project Name:	
Location:	
Item:	Qty:
Model:	

HUBM-23RB / HUBM-48RB / HUBM-72RB

GLASS DOOR MERCHANDISER REFRIGERATORS



HUBM-23RB



HUBM-48RB
(Also comes with sliding doors)





HUBM-72RB
(Also comes with sliding doors)

FEATURES

Hubert Glass Door Merchandiser Refrigerators are designed for durability and visual appeal to increase the visibility of your product to promote sales and enhance profits. Featuring a bottom mounted compressor, the glass door merchandisers effectively keep product at exactly the right temperature while utilizing energy efficiency. The simple to use but precise digital controls allow for accurate and flexible use of the unit. For energy savings, durability, and visually appealing construction, Hubert Glass Door Merchandiser Refrigerators are sure to be a hit.

- Coated steel exterior and interior
- Electronic thermostat and digital LED temperature display for accurate control and easy reading
- CFC free refrigerant and foam
- Self-closing door
- Magnetic gasket
- Double pane glass
- Powder coated cold rolled steel walls and cabinet, stainless steel floor
- LED lamps
- Available in 120V/60Hz/1

 	Specifications subject to change without notice.
	Approvals: UL Listed, UL Environment and Public Health Certification



HUBM-23RB / HUBM-48RB / HUBM-72RB

GLASS DOOR MERCHANDISER REFRIGERATORS

DIMENSIONS

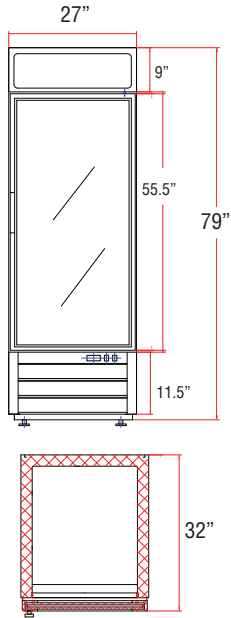

► HUBM-23RB

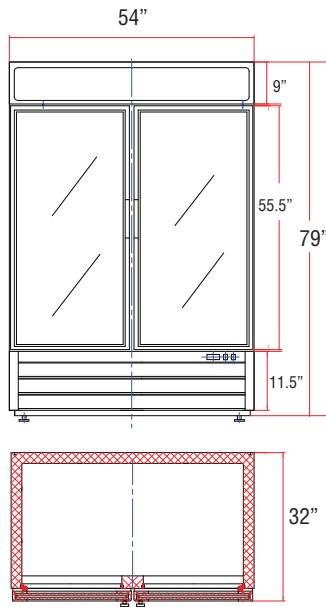

► HUBM-48RB

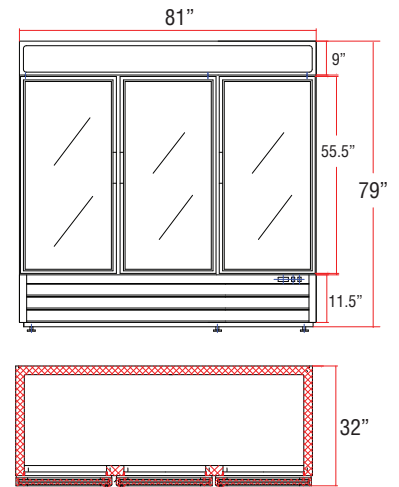

► HUBM-72RB

Model	Dim (W"xD"xH")	Capacity	Amps	Temp	Doors	Weight	Shelves
HUBM-23RB Refrigerator Black MDSR,Glass Door(1)	26.8 x 31.9 x 79.5 681 x 810 x 2019 mm	23 Cu Ft 651 L	6	33° to 41°F .5° to 5°C	1 Hinged	282 lb 128 kg	4
HUBM-48RB Refrigerator Black MDSR,Glass Door(2)	54 x 31.9 x 79.5 1372 x 810 x 2019 mm	48 Cu Ft 1359 L	7	33° to 41°F .5° to 5°C	2 Hinged	448 lb 203 kg	8
HUBM-72RB Refrigerator Black MDSR,Glass Door(3)	81 x 31.9 x 79.5 2057 x 810 x 2019 mm	72 Cu Ft 2,039 L	10	33° to 41°F .5° to 5°C	3 Hinged	618 lb 280 kg	12