



**INSTALLATION
AND
OPERATING
INSTRUCTIONS**

Models: XTRM-2 3", XTRM-3 3"

RADIANT CONVEYOR TOASTER

INTENDED FOR OTHER THAN HOUSEHOLD USE

**RETAIN THIS MANUAL FOR FUTURE REFERENCE
UNIT MUST BE KEPT CLEAR OF COMBUSTIBLES AT ALL TIMES**

! **FOR YOUR SAFETY:** Do not store or use gasoline or other flammable vapors and liquids in the vicinity of this or any other appliance. **!**

! **WARNING:** Improper installation, adjustment, alteration, service or maintenance can cause property damage, injury or death. Read the Installation, Operating and Maintenance Instructions thoroughly before installing or servicing this equipment. **!**

Initial heating of unit may generate smoke or fumes and must be done in a well ventilated area. Overexposure to smoke or fumes may cause nausea or dizziness.

This equipment has been engineered to provide you with year-round dependable service when used according to the instructions in this manual and standard commercial kitchen practices.



Phone: +1 (214) 421-7366
Fax: +1 (214) 565-0976
Toll Free: +1 (800) 527-2100
Website: www.apwwyott.com
E-mail: info@apwwyott.com

P/N 93030077 9/06

APW WYOTT
729 Third Avenue
Dallas, TX 75226

IMPORTANT FOR FUTURE REFERENCE

Please complete this information and retain this manual for the life of the equipment. For Warranty Service and/or Parts, this information is required.

Model Number

Serial Number

Date Purchased

Notes: _____

1. SAFETY PRECAUTIONS

Before installing and operating this equipment be sure everyone involved in its operation are fully trained and are aware of all precautions. Accidents and problems can result by a failure to follow fundamental rules and precautions.

The following words and symbols, found in this manual, alert you to hazards to the operator, service personnel or the equipment. The words are defined as follows:



DANGER: This symbol warns of imminent hazard which will result in serious injury or death.



WARNING: This symbol refers to a potential hazard or unsafe practice, which could result in serious injury or death.



CAUTION: This symbol refers to a potential hazard or unsafe practice, which may result in minor or moderate injury or product or property damage.



NOTICE: This symbol refers to information that needs special attention or must be fully understood even though not dangerous.



APW Wyott takes pride in the design and quality of our products. When used as intended and with proper care and maintenance, you will experience years of reliable operation from this equipment. To ensure best results, it is important that you read and follow the instructions in this manual carefully.

Installation and start-up should be performed by a qualified installer who thoroughly read, understands and follows these instruction.

If you have questions concerning the installation, operation, maintenance or service of this product, contact APW Wyott Foodservice Equipment Company's "Technical Service Department".

TABLE OF CONTENTS

SECTION	ITEM	PAGE
1	Safety Precautions	2
2	Important Safety Instructions	3
3	General Information	4
4	Installation Instructions	5
5	Operation Instructions	5
6	Cleaning Instructions	6
7	Specifications	6
8	Wiring Diagram	7
9	Parts Lists with Exploded Views	8
	XTRM-2 3"	8
	XTRM-3 3"	10
10	Warranty	12

2. IMPORTANT SAFETY INSTRUCTIONS

IMPORTANT: Read the following important safety instructions to avoid personal injury or death, and to avoid damage to the equipment or property.

WARNING: APW Wyott toasters are designed, built, and sold for commercial use. If positioned where the general public can use them, make sure that all cautions, warnings, and operating instructions are clearly posted near each unit to insure proper operation, reduce the chance of personal injury and/or equipment damage.

WARNING: Plug unit into a properly grounded electrical outlet of the correct voltage, size and plug configuration. If the plug and receptacle do not match, contact a qualified electrician to determine the proper voltage and size and install the proper electrical outlet.

WARNING: In Europe, appliance must be connected by an earthing cable to all other units in the complete installation and thence to an independent earth connection in compliance with EN 60335-1 and/or local codes

WARNING: Unit is not waterproof. Do not submerge in water. Do not operate if it has been submerged in water. Do not clean the unit with a water jet.

WARNING: To avoid any injury, turn the power switch off at the fuse disconnect switch/circuit breaker or unplug the unit from the power source and allow to cool completely before performing any maintenance or cleaning.



WARNING: To avoid electrical shock, always unplug the unit before performing cleaning or maintenance.



WARNING: An earthing cable must connect the appliance to all other units in the complete installation and from there to an independent earth connection.



WARNING: For safe and proper operation, the unit must be located a reasonable distance from combustible walls and materials. If safe distances are not maintained, discoloration or combustion could occur.



WARNING: To avoid electrical shock or personal injury, do not steam clean or use excessive water on the unit.



WARNING: If service is required on this unit, contact your authorized APW Wyott Service Agent, or contact the APW Wyott Service Department directly at (214) 421-7366 or (800) 527-2100; fax (214) 565-0976.



 **WARNING:** This product has no “user” serviceable parts. To avoid damage to the unit or injury to personnel, use only Authorized APW Wyott Service Agents and genuine APW Wyott Parts when service is required.. 



 **WARNING:** Genuine APW Wyott Replacement Parts are specified to operate safely in the environments in which they are used. Some aftermarket or generic replacement parts do not have the characteristics that will allow them to operate safely in APW Wyott equipment. It is essential to use APW Wyott Replacement Parts when repairing APW Wyott equipment. Failure to use APW Wyott Replacement Parts may subject operators of the equipment to hazardous electrical voltage, resulting in electrical shock or burn. 

 **CAUTION:** Some exterior surfaces on the unit will get hot. Use caution when touching these areas to avoid injury. 



 **CAUTION:** Locate the unit at the proper counter height, in an area that is convenient for use. The location should be level to prevent the unit or it’s contents from accidentally falling, and strong enough to support the weight of the unit and food. 

 **CAUTION:** Use only non-abrasive cleaners. Abrasive cleaners could scratch the finish of your unit, marring it’s appearance and making it susceptible to dirt accumulation. 

 **WARNING:** Failure to provide clearances will cause unit failure and invalidate warranty claims (see installation instructions). 

 **NOTICE:** Do not use toppings (butter, etc.) on product as product is inverted during normal operation. 

 **NOTICE:** Operating toaster without legs invalidates any warranty claims. 

 **NOTICE:** Neglecting to keep fan opening clean could result in toaster failure. 

3. GENERAL INFORMATION

- XTRM-2 3”:**
1. Overall Dimensions w/Wire Feeder - 16.067”H (408cm) x 16.254”W (41.13cm) x 20.511”D (521cm)
 2. Product Opening - 3.0”H (7.62cm) x 10.50”W (26.67cm)
 3. Electrical Requirements (Single phase):
 - A. 208 Volt, 2840 Watt, 13.7 Amp.
 - B. 230/240 Volt, 2840 Watt, 11.9 Amp.
 - C. Cordset configuration
 1. Each toaster equipped with three wire grounded cordset and standard 3 prong plug.
 4. Net/Shipping Weight – 51lb.(23.15kg) / 46lb.(20.865kg)

- XTRM-3 3”:**
1. Overall Dimensions w/Wire Feeder - 16.067”H (408cm) x 19.254”W (489cm) x 20.511”D (521cm)
 2. Product Opening - 3.0”H (7.62cm) x 13.50”W (34.29cm)
 3. Electrical Requirements (Single phase):
 - A. 208 Volt, 3340 Watt, 16.1 Amp.
 - B. 230/240 Volt, 3340 Watt, 14.0 Amp.
 - C. Cordset configuration
 1. Each toaster equipped with three wire grounded cordset and standard 3 prong plug.
 4. Net/Shipping Weight – 50 lb.(22.8kg) / 47 lb.(21.319kg)

4. INSTALLATION INSTRUCTIONS

I. Check Contents: Refer to Figure 1, account for the following parts:

- A. Remove foam pad and slide reflector tray in with wire feeder in upright position as shown.
- B. Ensure tray is properly engaged in tray slides. To do this simply hold the front of the tray higher than the rear as the back of the tray must slide under the slide on either side, You will know if done correctly because tray will be secure. No rocking or teetering will take place.
- C. Toast Drawer - shipped in place
- D. Instruction Manual - shipped loose

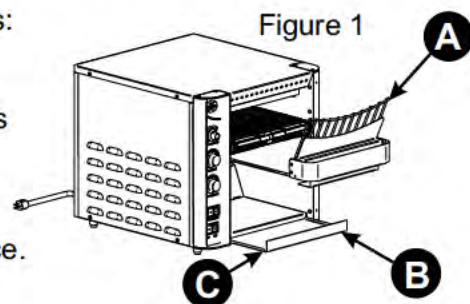

WARNING: Operating toaster without Reflector Tray reduces toasting capabilities.



2. Toaster Placement:

- A. Locate toaster near a grounded receptacle of the proper configuration (see below). Plug the cordset directly into receptacle (DO NOT USE AN EXTENSION CORD).
 1. In the U.S.: 208, 230/240V uses NEMA 6-20R.
- B. Place toaster on flat surface providing following minimum clearances:
 1. Base = one inch (provided with legs installed).
 2. Side and back walls = two inches
 3. Overhead = Enough space to allow adequate heat displacement.
- C. Position toaster where customers will not contact any surface labeled "CAUTION HOT".

5. OPERATION INSTRUCTIONS

1. Preparation

- A. Clean toaster thoroughly before first use (See cleaning instructions).
- B. Controls Familiarity
 1. Main Power Switch (located on very bottom of control panel): There are two rocker switches. The bottom switch powers the unit "ON". It also turns on the bottom element. The top switch is a standby switch that runs the top element. When the standby switch is in the "ON" position the unit is at full power. When the standby switch is in the "OFF" position the unit is running at 50%.
 - a) Full Power: Flip both rocker switches to the right.
 - b) Power Off: Flip both rocker switches to the left.
 - c) Warm-up time: Allow five (5) minutes.

2. Normal Use

- A. Loading Product
 1. Place product on Wire Feeder. The conveyor will automatically draw product through the toaster at a speed determined by conveyor speed control.
 2. Conveyor Speed Control: Set knob to the three (3) position for warm-up.

3. Thermostat Controls:

- A. The top thermostat runs the top element & the bottom thermostat runs the bottom element.
- B. Toasting Darkness: determined by conveyor speed & thermostat control.
 1. Darkest toasting - set conveyor speed control to far left setting & thermostat controls to highest setting.
 2. Lightest toasting - set conveyor speed control to far right setting.
 3. Other factors affecting toasting darkness.

- a) Product moistness - moister product requires slower speeds
 - b) Sugar content in product - product with more sugar requires slower speeds
 - c) Product Temperature - cooler product requires slower speeds
4. For best results, use day old bread stored room temperature.

6. CLEANING INSTRUCTIONS

1. Daily Cleaning

- A. With toaster off and cool, turn toaster on and set conveyor speed to four.
- B. Using a plastic abrasive pad, wipe the conveyor belt in a back and forth motion (side-to-side) motion to remove baked-on product. Wipe the conveyor belt in the same manner with a hot, damp cloth.
- C. Turn off toaster.
- D. Slide the reflector/crumb tray out of toaster by pulling forward. Dispose of crumbs and wash tray in hot, soapy water. Dry tray and place back in toaster.
- E. Remove toast drawer from toaster by sliding out and lifting up. Dispose of crumbs and wash drawer in hot, soapy water. Wipe crumbs from inside the toaster with a hot, damp cloth. Dry drawer and place back in toaster.
- F. Wipe the exterior surfaces of the toaster with a hot, damp cloth.

7. SPECIFICATIONS

XTRM-2 3 INCH

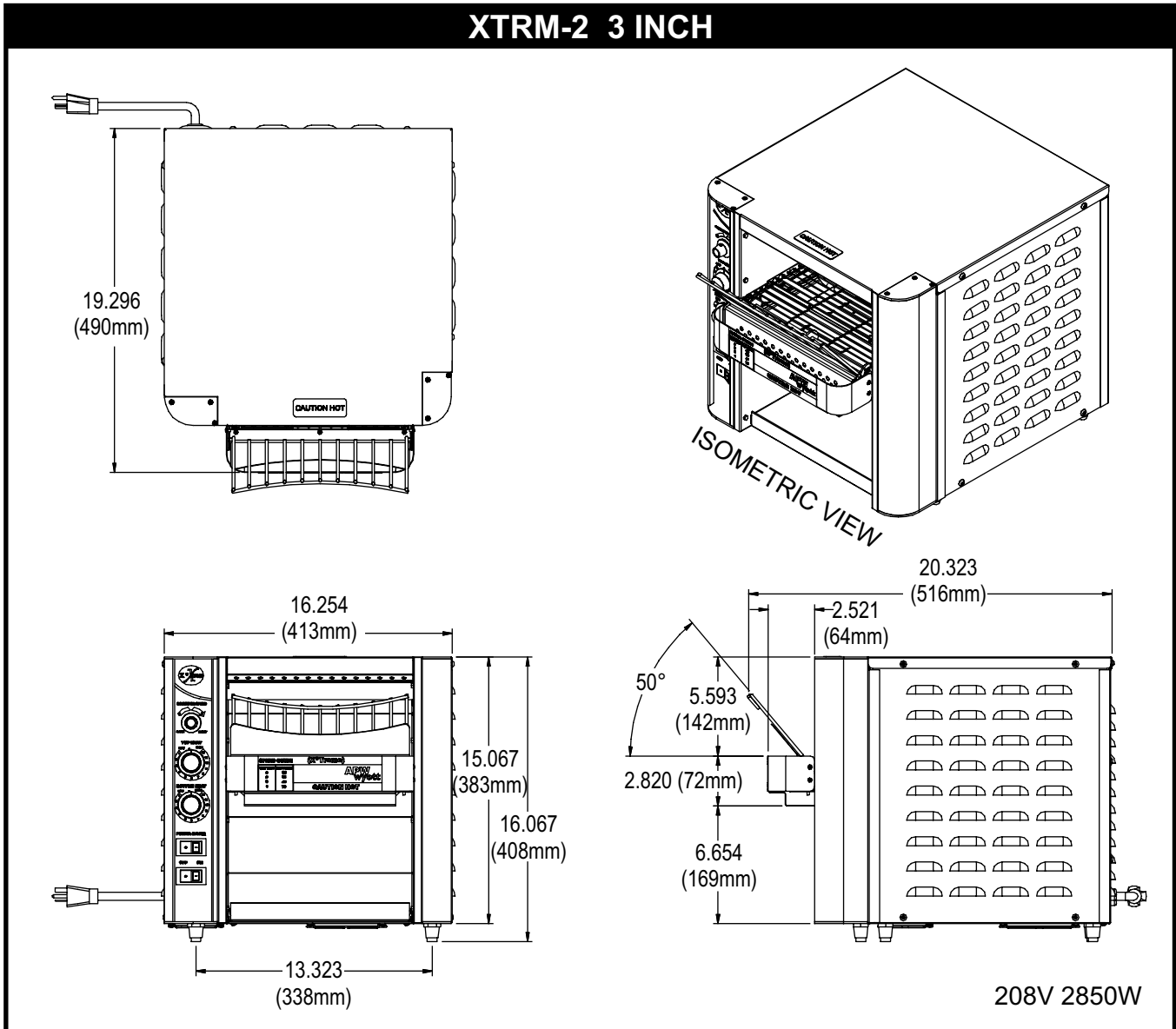

XTRM-3 3 INCH

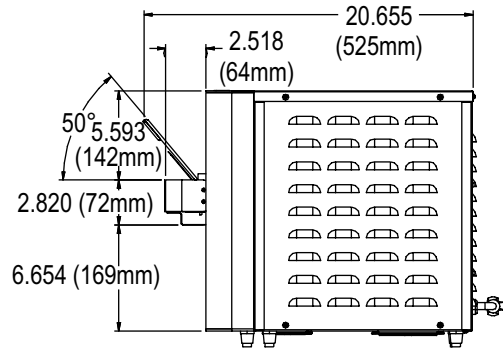
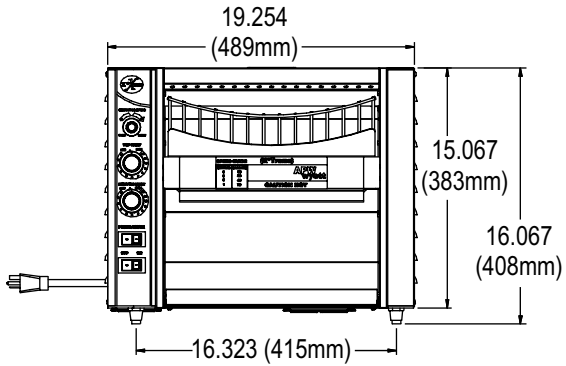
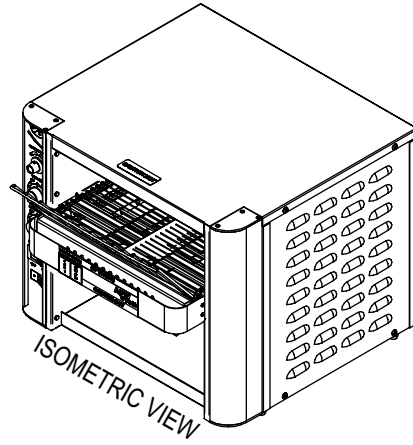
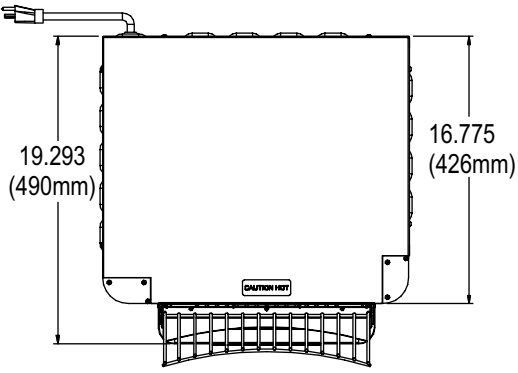

8. WIRING DIAGRAM

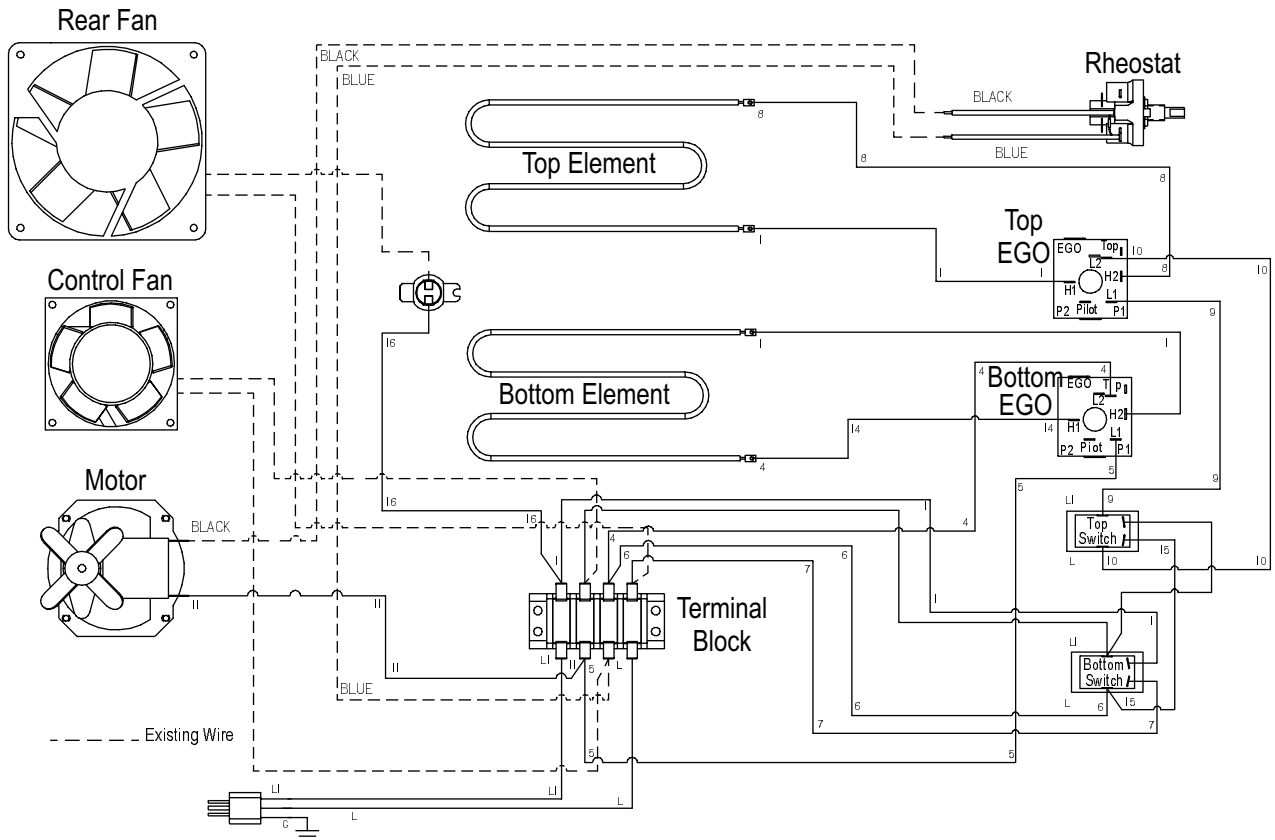

9. PARTS LISTS & EXPLODED VIEWS

XTRM-2 3 INCH - EXPLODED VIEW

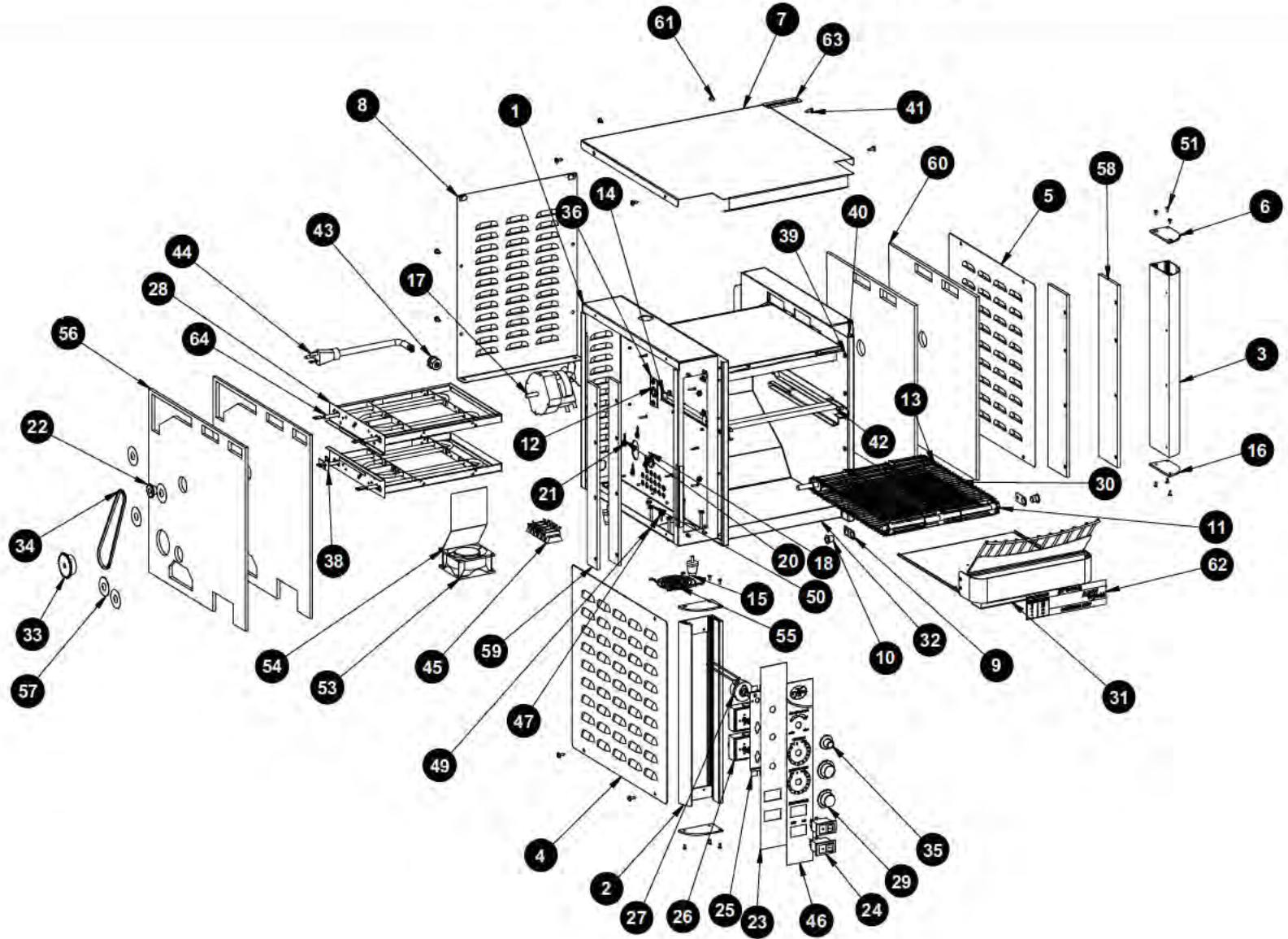

XTRM-2 3" PARTS LIST

ITEM	P/N	DESCRIPTION	QUAN	ITEM	P/N	DESCRIPTION	QUAN
1	93030040	XTRM-2 3", RIVIET ASSEMBLY	1	34	82902	CHAIN, 1/4" DRIVE 67 PITCH	1
2	93030158	XTRM-2 3"-CONTROL PANEL EXTRUSION	1	35	75617	KNOB W/NO'S. 0 TO 9	1
3	93030159	EXTRUSION, XTRM 2 3"	1	36	83821	BRACKET, BEARING	2
4	93030116	XTRM-2 3", PANEL, LEFT OUTER	1	37*	89061	NUT, HEX 10-24	10
5	93030115	XTRM-2 3", PANEL, RIGHT SIDE	1	38	93000194	XTRM 2&3, SMALL ELEMENT COVER	4
6	93000225	END CAP, F/L & B/R	2	39	93000229	HEX MACHINE SCREW, #6-32 X 3/4	8
7	93030181	COVER, TOP, XTRM 2	1	40	89073	SCREW, #8 X 1/2 HEX TAPIT SHT MTL TYPE AB	10
8	93030199	XTRM-2 3", BACK COVER	1	41	88889	SCREW #8 X 1/2 AB SMS PHL TRUSS LGM NI PLT	12
9	38130	ASSY, CLIP BEARING	2	42	81600087	SCREW, 8-32 x 3/8, PHILLIPS, PAN HEAD	2
10	38125	BEARING FLANGED POLYMER	2	43	89111	BUSHING, STRAIN RELIEF SR-7W-2	1
11	38122	W'ASSY IDLER SHAFT	1	44	83277	CORDSET, ASSY 208/240V (CORD 85640)	1
12	83248	BEARING, SHAFT	2	45	89145	TERMINAL BLOCK 300V-30AMPS	1
13	83956	DRIVE SHAFT ASSY AT-10 SEGMENTED BELT	1	46	93230064	LABEL, XTRM CONTROL 3"	1
14	83868	SPACER, CONVEYOR SHAFT	2	47	89054	NUT, KEPS 6-32	2
15	83267	LEG 1" PLASTIC W/CHROME	4	48*	85287	FAN GUARD	1
16	93000226	END CAP, B/L & F/R	2	49	88923	SCREW, 8-32x1-3/4 SLT PAN MS SS	8
17	85149	MOTOR, AT'S 208/240V 60HZ VARIABLE	1	50	89063	NUT, HEX 8-32	8
	85144	MOTOR, AT'S 230V 60HZ VARIABLE	1	51	94000114	SCREW, COUNTERSINK, 6-32X5/16,Z,BLK	12
18*	89184	BUSHING, .875 HEYCO 2126	1	52*	93200084	XTRM-3, INSULATION CENTER PANEL	1
19*	85284	FAN, COOLING 4.5" 105CFM 208/230V	1	53	85281	FAN,COOLING,3" DIA, 208/230V	1
20	89076	WASHER, LOCK 1/4 INTERNAL	4	54	93000196	XTRM-2 & 3 AIR DEFLECTOR	1
21	89030	SCREW, 10-32X3/4	4	55	85282	Guard, 3.15 Sq. Fan	1
22	83261	SPROCKET, 12 TOOTH 1/4 PITCH 3/8 BORE	1	56	93030227	XTRM-2 3", CONTROL BOX INSULATION	2
23	93230061	ASSY, PLATE, CONTROLS 3" XTRM	1	57	88940	WASHER, 1-1/2 RD	9
24	70444800	SWITCH, ROCKER ON-OFF	2	58	93030230	XTRM-2 3", RIGHT EXTRUSION INSULATION	2
25	93200066	PLATE, SPACE, CONTROLS	1	59	93030231	XTRM-2 3", LEFT EXTRUSION INSULATION	2
26	69104-EGO	INFINITE SWITCH-EGO (208V)	2	60	93030232	XTRM-2 3", RIGHT SIDE INSULATION	2
	69103-EGO	INFINITE SWITCH-EGO (230/240V)	2	61	89039	SCREW, 8-32X5/16 PH PAN SS	4
27	83333	RHEOSTAT 208/240 V. PIGGY-BACK TERM	1	62	93200303	LABEL, SPEED GUIDCAUTION HOT!	1
28	93000186	XTRM-2, ELEMENT RACK	2	63	58081	LABEL, CAUTION HOT!	1
29	88705	KNOB 039-266 8A BLACK	2	64	54093	ELEMENT, 208V-1400W	2
30	82920	BELT, WIRE 27x.05 3 SEG.	1		54094	ELEMENT, 230/240V-1400W	2
31	93100065	ASSY, XTRM 2 FEEDER	1	65*	69154	THERMOSTAT, THERM-O-DISC W/MOUNT CLIP	1
32	93100197	DRAWER TOAST	1	66*	89182	BUSHING, .5 HEYCO 2058	1
33	93000233	SPROCKET, 32 TOOTH 1/4 PITCH	1			*NOT SHOWN	

XTRM-3 3 INCH - EXPLODED VIEW

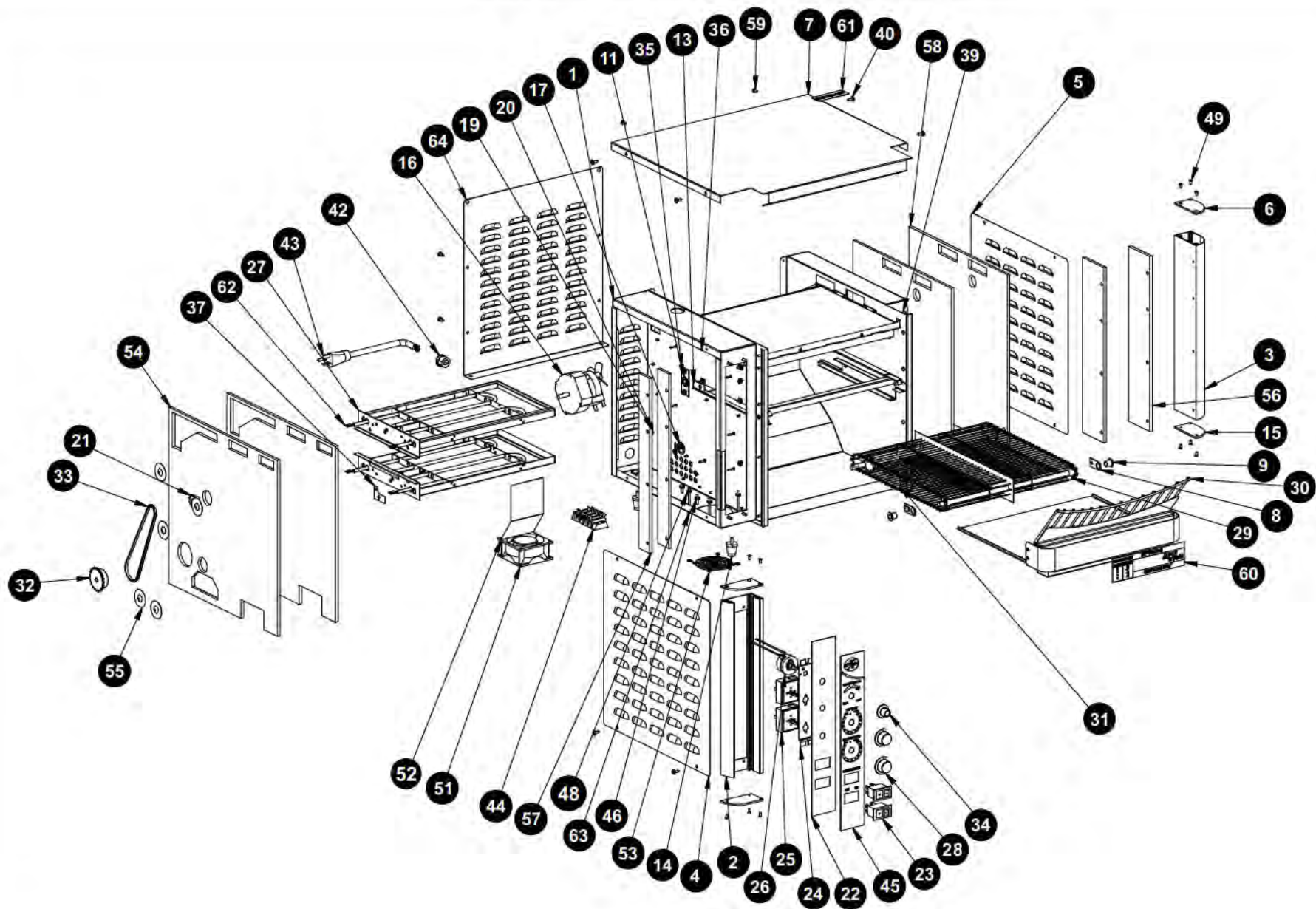

XTRM-3 3" PARTS LIST

ITEM	P/N	DESCRIPTION	QUAN	ITEM	P/N	DESCRIPTION	QUAN
1	93230040	XTRM 3 3", RIVIET ASSEMBLY	1	35	83821	BRACKET, BEARING	2
2	93030158	XTRM-2 3"-CONTROL PANEL EXTRUSION	1	36	89061	NUT, HEX 10-24	10
3	93030159	EXTRUSION, XTRM 2 3"	1	37	93000194	XTRM 2&3, SMALL ELEMENT COVER	4
4	93030116	XTRM-2 3", PANEL, LEFT OUTER	1	38*	93000229	HEX MACHINE SCREW, #6-32 X 3/4	8
5	93030115	XTRM-2 3", PANEL, RIGHT SIDE	1	39	89073	SCREW, #8 X 1/2 HEX TAPIT SHT MTL TYPE AB	10
6	93000225	END CAP, F/L & B/R	2	40	88889	SCREW #8 X 1/2 AB SMS PHL TRUSS LGM NI PLT	12
7	93230047	COVER, TOP, XTRM 3	1	41*	81600087	SCREW, 8-32 x 3/8, PHILLIPS, PAN HEAD	2
8	38130	ASSY, CLIP BEARING	2	42	89111	BUSHING, STRAIN RELIEF SR-7W-2	1
9	38125	BEARING FLANGED POLYMER	2	43	83277	CORDSET, ASSY 208/240V (CORD 85640)	1
10*	93200070	SHAFT, IDLER XTRM	1	44	89145	TERMINAL BLOCK 300V-30AMPS	1
11	83248	BEARING, SHAFT	2	45	93230064	LABEL, XTRM CONTROL 3"	1
12*	83976	ASSEMBLY, DRIVE SHAFT	1	46	89054	NUT, KEPS 6-32	2
13	83868	SPACER, CONVEYOR SHAFT	2	47*	85287	FAN GUARD	1
14	83267	LEG 1" PLASTIC W/CHROME	4	48	89063	NUT, HEX 8-32	9
15	93000226	END CAP, B/L & F/R	2	49	94000114	SCREW, COUNTERSINK, 6-32X5/16,Z,BLK	12
16	85149	MOTOR, AT'S 208/240V 60HZ VARIABLE	1	50*	93200084	XTRM-3, INSULATION CENTER PANEL	1
	85144	MOTOR, AT'S 230V 60HZ VARIABLE	1	51	85281	FAN,COOLING,3" DIA, 208/230V	1
17	89184	BUSHING, .875 HEYCO 2126	1	52	93000196	XTRM-2 & 3 AIR DEFLECTOR	1
18*	85284	FAN, COOLING 4.5" 105CFM 208/230V	1	53	85282	Guard, 3.15 Sq. Fan	1
19	89076	WASHER, LOCK 1/4 INTERNAL	4	54	93030227	XTRM-2 3", CONTROL BOX INSULATION	2
20	89030	SCREW, 10-32X3/4	4	55	88940	WASHER, 1-1/2 RD	9
21	83261	SPROCKET, 12 TOOTH 1/4 PITCH 3/8 BORE	1	56	93030230	XTRM-2 3", RIGHT EXTRUSION INSULATION	2
22	93230061	ASSY, PLATE, CONTROLS 3" XTRM	1	57	93030231	XTRM-2 3", LEFT EXTRUSION INSULATION	2
23	70444800	SWITCH, ROCKER ON-OFF	2	58	93030232	XTRM-2 3", RIGHT SIDE INSULATION	2
24	93200066	PLATE, SPACE, CONTROLS	1	59	89039	SCREW, 8-32X5/16 PH PAN SS	4
25	69104-EGO	INFINITE SWITCH-EGO (208V)	2	60	93200303	LABEL, SPEED GUIDCAUTION HOT!	1
	69103-EGO	INFINITE SWITCH-EGO (230/240V)	2	61	58081	LABEL, CAUTION HOT!	1
26	83333	RHEOSTAT 208/240 V. PIGGY-BACK TERM	1	62	54021	ELEMENT, 208V - 1650W	2
27	93200036	XTRM 3, ELEMENT RACK	2		54032	ELEMENT, 230/240V - 1650W	2
28	88705	KNOB 039-266 8A BLACK	2	63	88951	SCREW, 8-32x2" PHILLIPS PAN MS SS	8
29	83880	CONVEYOR BELT 79 LINKS	1	64	93230199	XTRM 3 3", BACK COVER	1
30	93200052	ASSY, XTRM 3 FEEDER	1	65*	69154	THERMOSTAT, THERM-O-DISC W/MOUNT CLIP	1
31	93200048	XTRM-3, TOASTER DRAWER	1	66*	89056	WASHER #8 INTERNAL LOCK, SS	1
32	93000233	SPROCKET, 32 TOOTH 1/4 PITCH	1	67*	89182	BUSHING, .5 HEYCO 2058	1
33	82902	CHAIN, 1/4" DRIVE 67 PITCH	1				
34	75617	KNOB W/NO'S. 0 TO 9	1			*NOT SHOWN	

10. APW WYOTT EQUIPMENT LIMITED WARRANTY

APW Wyott Foodservice Equipment Company warrants its equipment against defects in materials and workmanship, subject to the following conditions:

This warranty applies to the original owner only and is not assignable.

Should any product fail to function in its intended manner under normal use within the limits defined in this warranty, at the option of APW Wyott such product will be repaired or replaced by APW Wyott or its Authorized Service Agency. APW Wyott will only be responsible for charges incurred or service performed by its Authorized Service Agencies. The use of other than APW Wyott Authorized Service Agencies will void this warranty and APW Wyott will not be responsible for such work or any charges associated with same. The closest APW Wyott Authorized Service Agent must be used.

This warranty covers products shipped into the 48 contiguous United States, Hawaii, metropolitan areas of Alaska and Canada. There will be no labor coverage for equipment located on any island not connected by roadway to the mainland.

Warranty coverage on products used outside the 48 contiguous United States, Hawaii, and metropolitan areas of Alaska and Canada may vary. Contact the international APW Wyott distributor, dealer, or service agency for details.

Time Period

One year for parts and one year for labor, effective from the date of purchase by the original owner. The Authorized Service Agency may, at their option, require proof of purchase. Parts replaced under this warranty are warranted for the un-expired portion of the original product warranty only.

Exceptions

- ***Gas/Electric Cookline:** Models GCB, GCRB, GF, GGM, GGT, CHIP-II, EF, EG, EHP. Three (3) Year Warranty on all component parts, except switches and thermostats. (2 additional years on parts only. No labor on second or third year.)
- ***Broiler Briquettes, Rock Grates, Cooking Grates, Burner Shields, Fireboxes:** 90 Day Material Only. No Labor
- ***Heat Strips:** Models FD, FDL, FDD, FDDL. Two (2) Year Warranty on element only. No labor second year.
- ***Glass Windows, Doors, Seals, Rubber Seals, Light Bulbs:** 90 Day Material Only. No Labor.

In all cases, parts covered by extended warranty will be shipped FOB the factory after the first year.

Portable Carry In Products

Equipment weighing over 70 pounds or permanently installed will be serviced on-site as per the terms of this warranty. Equipment weighing 70 pounds or under, and which is not permanently installed, i.e. with cord and plug, is considered portable and is subject to the following warranty handling limitations. If portable equipment fails to operate in its intended manner on the first day of connection, or use, at APW Wyott's option or its Authorized Service Agency, it will be serviced on-site or replaced.

From day two through the conclusion of this warranty period, portable units must be taken to or sent prepaid to the APW Wyott Authorized Service Agency for in-warranty repairs. No mileage or travel charges are allowed on portable units after the first day of use. If the customer wants on-site service, they may receive same by paying the travel and mileage charges. Exceptions to this rule: (1) countertop warmers and cookers, which are covered under the Enhanced Warranty Program, and (2) toasters or rollergrills which have in store service.

Exclusions

The following conditions are not covered by warranty:

- *Equipment failure relating to improper installation, improper utility connection or supply and problems due to ventilation.
- *Equipment that has not been properly maintained, calibration of controls, adjustments, damage from improper cleaning and water damage to controls.
- *Equipment that has not been used in an appropriate manner, or has been subject to misuse or misapplication, neglect, abuse, accident, alteration, negligence, damage during transit, delivery or installation, fire, flood, riot or act of god.
- *Equipment that has the model number or serial number removed or altered.

If the equipment has been changed, altered, modified or repaired by other than an Authorized Service Agency during or after the warranty period, then the manufacturer shall not be liable for any damages to any person or to any property, which may result from the use of the equipment thereafter.

This warranty does not cover services performed at overtime or premium labor rates. Should service be required at times which normally involve overtime or premium labor rates, the owner shall be charged for the difference between normal service rates and such premium rates. APW Wyott does not assume any liability for extended delays in replacing or repairing any items beyond its control.

In all cases, the use of other than APW Wyott Authorized OEM Replacement Parts will void this warranty.

This equipment is intended for commercial use only. Warranty is void if equipment is installed in other than commercial application.

Water Quality Requirements

Water supply intended for a unit that has in excess of 3.0 grains of hardness per gallon (GPG) must be treated or softened before being used. Water containing over 3.0 GPG will decrease the efficiency and reduce the operation life of the unit.

Note: Product failure caused by liming or sediment buildup is not covered under warranty.

"THE FOREGOING WARRANTY IS IN LIEU OF ANY AND ALL OTHER WARRANTIES EXPRESSED OR IMPLIED INCLUDING ANY IMPLIED WARRANTY OF MERCHANTABILITY OR FITNESS FOR PARTICULAR PURPOSES AND CONSTITUTES THE ENTIRE LIABILITY OF APW WYOTT. IN NO EVENT DOES THE LIMITED WARRANTY EXTEND BEYOND THE TERMS STATED HEREIN."

9/05