

BURNSIDE

ASSEMBLY INSTRUCTIONS

3 WAY // 292-3WAY

Made of 1¼" square tubing in Metallic Silver finish

4" steel/rubber casters (2 locking)

Use with optional 47¾" x 20" Perforated Metal or Frosted Acrylic Back Panels available and sold separately

25¾" x 26¾" x 57.15"

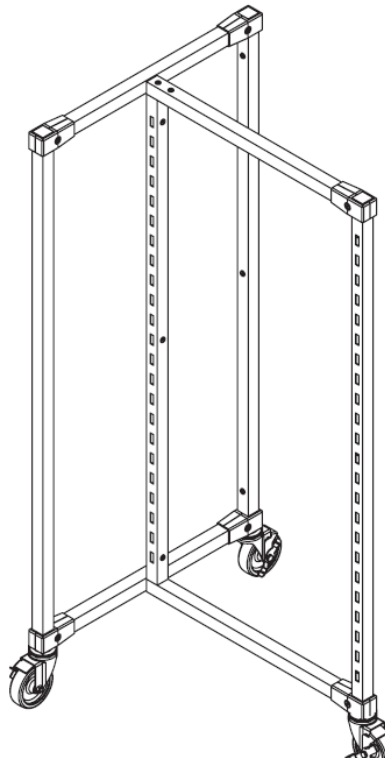

BURNSIDE

ASSEMBLY INSTRUCTIONS

3 WAY

Step 1: Connect center frame to end panel.

Step 2: Attach casters.

