



Project:

Item Number:

Quantity:

CAYENNE® HOT FOOD MERCHANDISERS



Cayenne® Hot Food Merchandiser

MODELS

40733 FMA7026 26" Merchandiser

40734 FMA7036 36" Merchandiser

40735 FMA7048 47" Merchandiser

FEATURES

- Thermostatically controlled heat with 85° to 175°F (29° to 79°C) temp range
- Specially designed baffle for even temperature distribution
- Internal humidifying system to keep food looking fresh longer
- Front and rear sliding doors for easy loading and customer self-serve convenience. Door can be locked.
- Three adjustable shelves for versatile displays
- Illuminated display for bright, eye-catching merchandising
- Lights controlled separately. Lights can be used without heat
- 5 ft. (1.5 m) cord and plug

DESCRIPTION

The Cayenne® Hot Food Merchandiser is the ideal solution for presenting and keeping warm a variety of food products. Variable heat control with humidity keeps food at the right temperature. Three adjustable tiered shelves accommodate and attractively merchandise an endless variety of food products. Front and rear sliding lockable doors make restocking easy and are ideal for self-serve operations.

WARRANTY: All models shown come with Vollrath's standard warranty against defects in materials and workmanship. For full warranty details, please refer to the Vollrath Equipment and Smallwares Catalog.

AGENCY CERTIFICATIONS



Due to continued product improvement, please consult www.vollrathco.com for current product specifications.

Approvals

Date



Setting the Standard™

www.vollrathco.com

The Vollrath Company, L.L.C.
 1236 North 18th Street
 Sheboygan, WI 53081-3201 U.S.A.
 Customer Service: 800.628.0830
 Canada Customer Service: 800.695.8560
 Main Fax: 800.752.5620 or 920.459.6573

Technical Services: 800.628.0832
 Technical Services Fax: 920.459.5462

CAYENNE® HOT FOOD MERCHANDISERS

MODELS	40733	FMA7026	26" Merchandiser
	40734	FMA7036	36" Merchandiser
	40735	FMA7048	47" Merchandiser

DIMENSIONS

Dimensions shown in inches (cm).

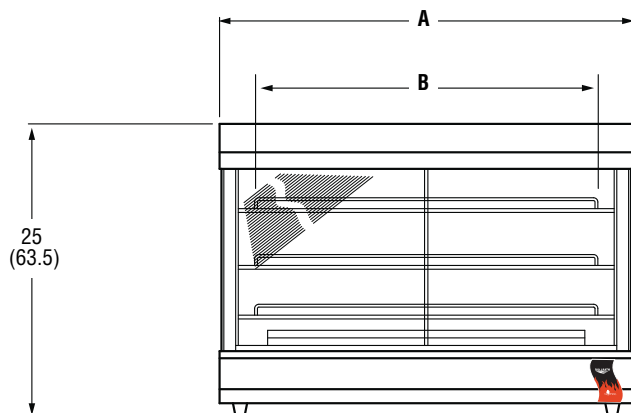

Front View

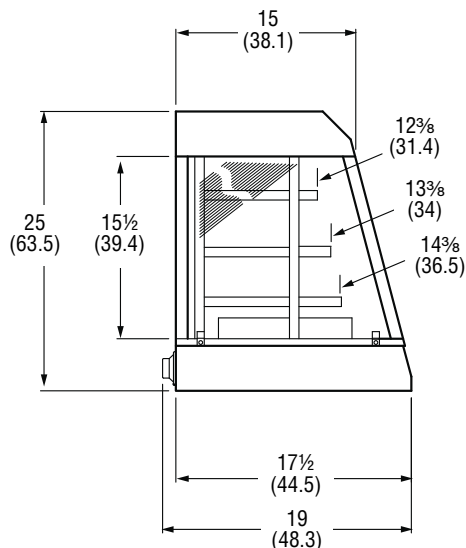

Side View

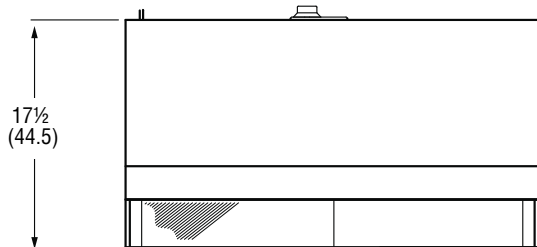

Top View

SPECIFICATIONS

Item	(A) Overall Width	(B) Shelf Width	Voltage	Watts	Amps	Ship Weight Lb (Kg)	Plug
40733	26 (66)	23½ (59.7)	120 AC	1440	12	85 (38.6)	5-15P
40734	36 (91.4)	32¼ (81.9)	120 AC	1440	12	108 (49)	5-15P
40735	47 (119.4)	44 (11.8)	120 AC	1440	12	156 & 0.8)	5-15P

Receptacle

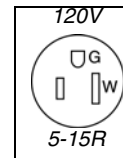

www.vollrathco.com

The Vollrath Company, L.L.C.
 1236 North 18th Street
 Sheboygan, WI 53081-3201 U.S.A.
 Customer Service: 800.628.0830
 Canada Customer Service: 800.695.8560
 Main Fax: 800.752.5620 or 920.459.6573

Technical Services: 800.628.0832
 Technical Services Fax: 920.459.5462