

WILBUR CURTIS COMPANY, Inc.

Service Manual – CAFEP C

Important Safeguards/Conventions

This appliance is designed for commercial use. Any servicing other than cleaning and maintenance should be performed by an authorized Wilbur Curtis service center.

- Do NOT immerse the unit in water or any other liquid
- To reduce the risk of fire or electric shock, do NOT open top panel. No user serviceable parts inside. Repair should be done only by authorized service personnel.
- Keep hands and other items away from hot parts of unit during operation.
- Never clean with scouring powders or harsh implements.

Conventions



WARNINGS – To help avoid personal injury

Important Notes/Cautions – from the factory

Sanitation Requirements

Models Included

- ◆ CAFE PC1
- ◆ CAFE PC1 WITH LIGHT BOX
- ◆ CAFE PC2
- ◆ CAFE PC2 WITH LIGHT BOX
- ◆ CAFE PC3
- ◆ CAFE PC3 ICED CAPPUC-CINO
- ◆ CAFE PC3 WITH LIGHT BOX
- ◆ CAFE PC4
- ◆ CAFE PC4 WITH LIGHT BOX



WARNING HOT LIQUID,
Scalding may occur.
Avoid splashing.



CAUTION: Please use this setup procedure before attempting to use this appliance. Failure to follow the instructions can result in injury or the voiding of the warranty.



CAUTION: DO NOT connect this unit to hot water. The inlet valve is not rated for hot water.

Your Curtis ADS System is Factory Pre-Set and Ready to Go... Right from the Carton.

Following are the Factory Settings for your Primo Cappuccino Beverage System:

- **Tank Temperature = 190°F**
- **Flavor Controls= Set at 60%**
- **Dispensing Mode Set for Manual Dispensing**

Generally there will never be a reason to change your programming. However, should you need to make slight adjustments to meet your dispensing needs, programming instructions are provided later in this manual.

System Requirements:

- **Water Source** 20 – 90 PSI (Minimum Flow Rate of 1 GPM)
- **Electrical:** See attached schematic for standard model or visit www.wilburcurtis.com for your model.

Equipment to be installed to comply with applicable federal, state, or local plumbing/electrical codes having jurisdiction.

SETUP STEPS

The unit should be level (left to right and front to back), located on a solid counter top. Connect a water line from the water filter to the brewer. **NOTE:** Some type of water filtration device must be used to maintain a trouble-free operation. (In areas with extremely hard water, we suggest that a sedimentary and taste & odor filter be installed.) This will prolong the life of your dispensing system and enhance cappuccino product quality.



NSF International requires the following water connection:

1. A quick disconnect or additional coiled tubing (at least 2x the depth of the unit) so that the machine can be moved for cleaning underneath.
2. In some areas an approved backflow prevention device may be required between the brewer and the water supply.

1. Connect a water line from your facility to the 1/4" flare water inlet fitting of the valve, behind the machine. Water volume going to the machine should be stable. Use tubing sized sufficiently to provide a minimum flow rate of one gallon per minute.
2. Plug the power cord into an electrical outlet rated at 20A.
3. Switch on the toggle switch, behind the unit, that runs power to the components in the machine. The display window and Stop/Wash light on the front door will activate and the heating tank will start to fill.
4. Water in the heating tank will require about ½ hour to reach operating temperature (factory setting of 190°F). At this time the Ready LED will light.
5. Remove and fill the canisters with powdered cappuccino mixes.

OPERATION INSTRUCTIONS

1. Choose a flavor. Place your cup under the spout beneath the desired flavor.
2. Push and hold the dispensing button for this flavor.
3. Release the button when the cup is ¾ full.

FILL CANISTERS DAILY

1. Open the front door to access the coffee canisters.
2. The canisters must be removed from the unit for filling. Turn the product delivery elbows upward.
3. Reposition the canisters on the machine, turning the product delivery elbows downward and aligning the gear socket with the motor shaft.

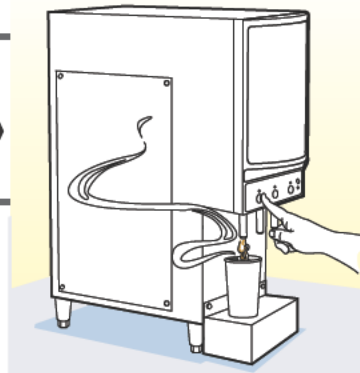

Steps to Programming

Your Curtis Cafe System is Factory Pre-Set for Optimum Performance. Usually this Does Not Change.



WARNING HOT LIQUID, Scalding may occur. Avoid splashing. Place an empty container under the dispensing nozzles while programming.

All programming is performed at the control panel (illustration, right).

The **STOP/WASH BUTTON** has several functions. This button is used to stop a Portion Control dispense cycle. It is used to wash out the mixing and dispensing systems and it is used to enter programming functions.

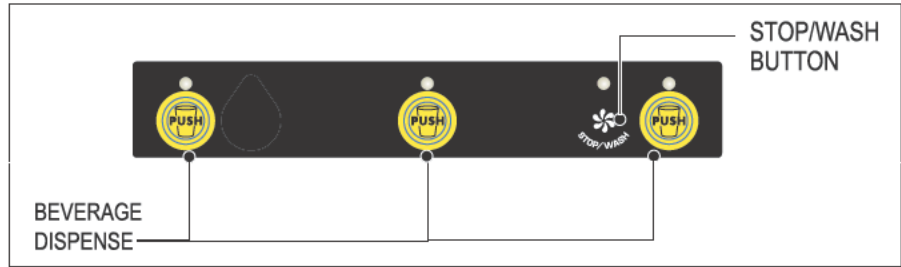

Product % Ratio

This controls the amount of dry product that is metered from the hoppers. This can be programmed from 10% to 100% of the capacity of the dispensing system. By counting LED flashes you can determine the product % ratio currently set for this dispense button (see table).

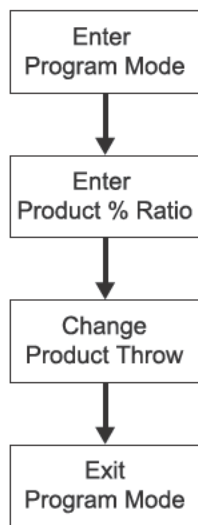

Enter Program Mode – press and hold **STOP/WASH** for about ten [10] seconds until all lights start blinking.

To program Product % Ratio, press and hold the selected **PUSH** button for approximately one second, then release. The current setting will be indicated by LED flashes.

PRODUCT RATIO	
Number of Flashes	Volume
1	10%
2	20%
3	30%
4	40%
5	50%
6	60%
7	70%
8	80%
9	90%
10	100%

To change the product throw, press and hold the button until light starts quick flashing. Each quick flash increases the amount by 10%. Release the button when the desired throw amount is achieved. After releasing the button, the number of blinks represent the new setting.

To exit the Powder Dispensing Mode, push any other **PUSH** button.

Portion Control Liquid Dispensing Mode

This program adjustment allows you to setup the machine to automatically dispense a preset volume of cappucino product. When the user makes a **PUSH** button selection, the unit dispenses only the volume of cappucino product programmed by the Portion Control Dispensing Mode. By setting the unit for Portion Control Dispensing, you have locked out the manual dispense feature.

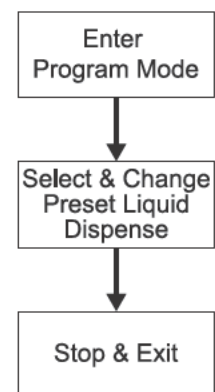

Enter Program Mode – press and hold **STOP/WASH** for about ten [10] seconds until all lights start blinking.

To select & change the Portion Control Dispensing Volume – while in the programming mode, press and hold the selected **PUSH** button until the liquid begins to flow, then release. The timing starts when liquid begins to flow.

Stop & Exit – When 3/4 of the cup volume is achieved, press the **PUSH** button once again to stop the dispensing. You have now set the timing for this button and have exited the programming mode. Pressing the dispense button now will provide the liquid volume that you just set. To reset the timing, you must start again by entering the programming mode.

Manual Liquid Dispensing Mode

This feature sets up the Café PC unit to dispense product only as long as the user holds down the selected **PUSH** button.

As soon as the user stops pressing the button, product stops flowing into the cup. Setting the unit for Manual Liquid Dispense will turn off the Portion Control Dispense Mode.

Programming Continued ...

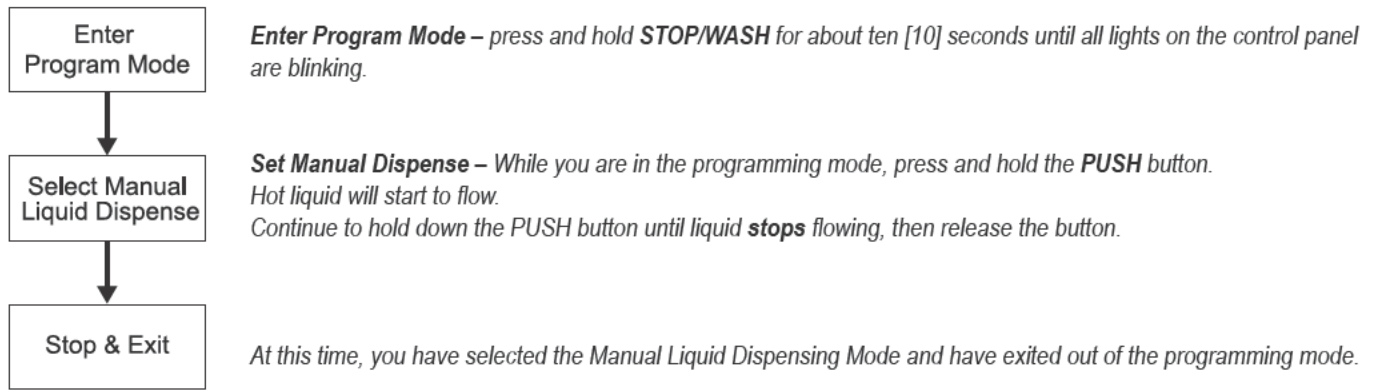

Confirm/Reset Temperature (Factory set at 190°F . . . Cold Cappuccino set at 100°F)

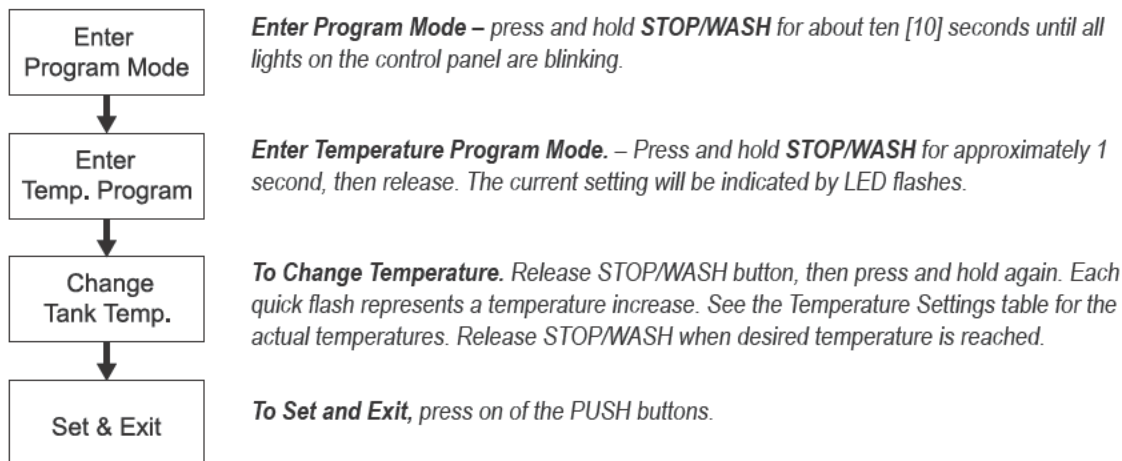

These features allow you to check the heating tank temperature or change the temperature if desired. The temperature in the tank is programmable from 80°F, in 5 degree increments up to 140°F, then temperature will jump 45 degrees to 185°F, then resume 2 degree increments up to a maximum 204°F (see Temperature Settings table, right).

To Change Tank Temperature



Temperature Settings	
Number of Blinks	Temperature
1	80°F
2	85°F
3	90°F
4	95°F
5	100°F
6	105°F
7	110°F
8	120°F
9	140°F
10	185°F
11	190°F
12	192°F
13	194°F
14	196°F
15	198°F
16	200°F
17	202°F
18	204°F

ERROR CODES: Curtis Cafe systems contain various safety features in the electronic circuitry that shut down the functions of the unit in the event of a system failure. Error codes are signalled by the **READY** light blinking one of three patterns:

- | | |
|---|---|
|  | WATER LEVEL ERROR – 3 LONG AND 1 SHORT
When this code is seen on the control panel, there is a malfunction in the water level control system. |
|  | TEMPERATURE SENSOR ERROR – 3 LONG AND 2 SHORT
When this light pattern is flashing on the control panel there is a system failure with the heating tank. |
|  | COMMUNICATION ERROR – 3 LONG AND 3 SHORT
This flashing light pattern indicates a communication error between the switch panel on the door and the power module. |

Flushing the Whipper Chambers

Every three to four hours or more often if necessary flush the whipper chamber/dispensing system.

- A. Make sure power is ON.
- B. Press and hold the **STOP/WASH** button. Select one of the **PUSH** dispensing buttons and press. Hot rinse water will flush out the system. Lift off the **STOP/WASH** button when water runs clear.
- C. Clean up any water that may have spilled.

Cleaning

- A. Switch off the unit at the power toggle switch, marked **CONTROL**, behind the unit.
- B. Wipe all exterior surfaces with a damp cloth; removing any spills, dust or debris from the unit.
- C. Remove the drip tray and louvered screen and wash out its contents. For hard to clean deposits, use a mild detergent solution.
- D. Clean around the dispensing area, wiping with a nontoxic cleaner.

Dump Valve Replacement



We recommend that you regulate the water flow in the valve **ONLY** when replacing a valve.



WARNING: As with all electrical equipment, caution must be taken to avoid electrical shock. Be sure the power cord is disconnected before removing components. The following steps will also involve working near hot surfaces.

I. Instructions for replacing a valve:

- A. Shut off the water line running into the unit.
- B. Disconnect the power cord or turn off the unit at the toggle switch behind the unit.
- C. Drain approximately $\frac{1}{2}$ to $\frac{3}{4}$ gallon of water from the tank by pressing on of the dispense buttons. This will insure that the water level is below the level of the valves. Remove the wires and water tubing from the defective valve and pull it from the silicone fitting.
- D. Before installing on the tank, make an initial adjustment with the valve off of the tank.
 1. Loosen the screw on the metal guard. Rotate away from the adjustment screw (fig. 1.).
 2. Carefully, turn flow adjustment screw clockwise all the way in (see figure 2.). Observe restrictor position. Do not overtighten.
 3. Now turn the flow adjustment screw counter clockwise three [3] turns (or $1\frac{1}{2}$ turns from the fully open position).
 4. Replace the metal guard.
 5. Install the valve on the tank, attaching wires and silicone tube. Press the valve fully into the fitting on the heating tank.

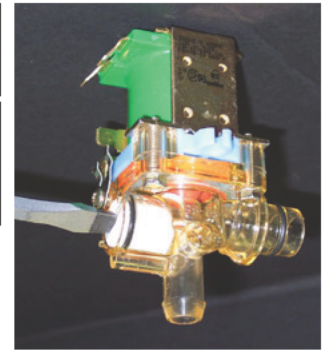

Figure 1 Adjustment

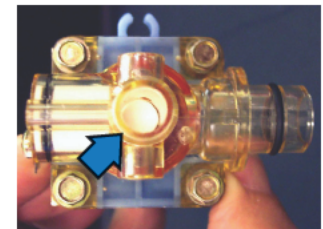

Figure 2 Restrictor Closed

II. Dump valve, water flow adjustment:

The Water flow is preset to ensure optimum mixing and proper chamber rinsing. The valves currently installed on your unit have been set at the factory and should not require adjusting. The factory flow rate setting is 8 oz. of water in 10 seconds (or 0.8 oz./sec.).

Replacing Film in Light Box

1. Turn OFF power by unplugging the power cord.
2. Open the front door and remove the six screws that attach the light box.
3. Pull off the light box assembly from the door. Detach at the hook at the top of the light box (illustration, right item 1).
4. Take out old film, unhooking it from the bottom tabs and sliding it out of the frame.
5. Insert the new film, slide it into the frame and hook it under the tabs to secure it (see illustration below).
6. Return the light box to the front door. From inside the door, insert the six screws that were removed in step #2.
7. Close the front door and plug in the power cord. The light box should come on.
8. Check that the film lies flat and there is no light leaking from the edges. If okay, the Curtis CAFEPC unit is ready to use.

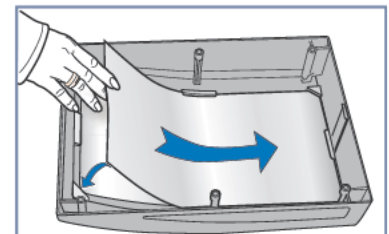
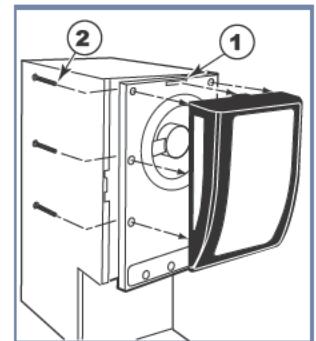

Whipper Plate Replacement

Shaft seals should be replaced with the grooved side facing outward.



Before mounting a whipper plate, place a dab of food grade lubricant in the rear hole of the seal.



Illustrated Parts List

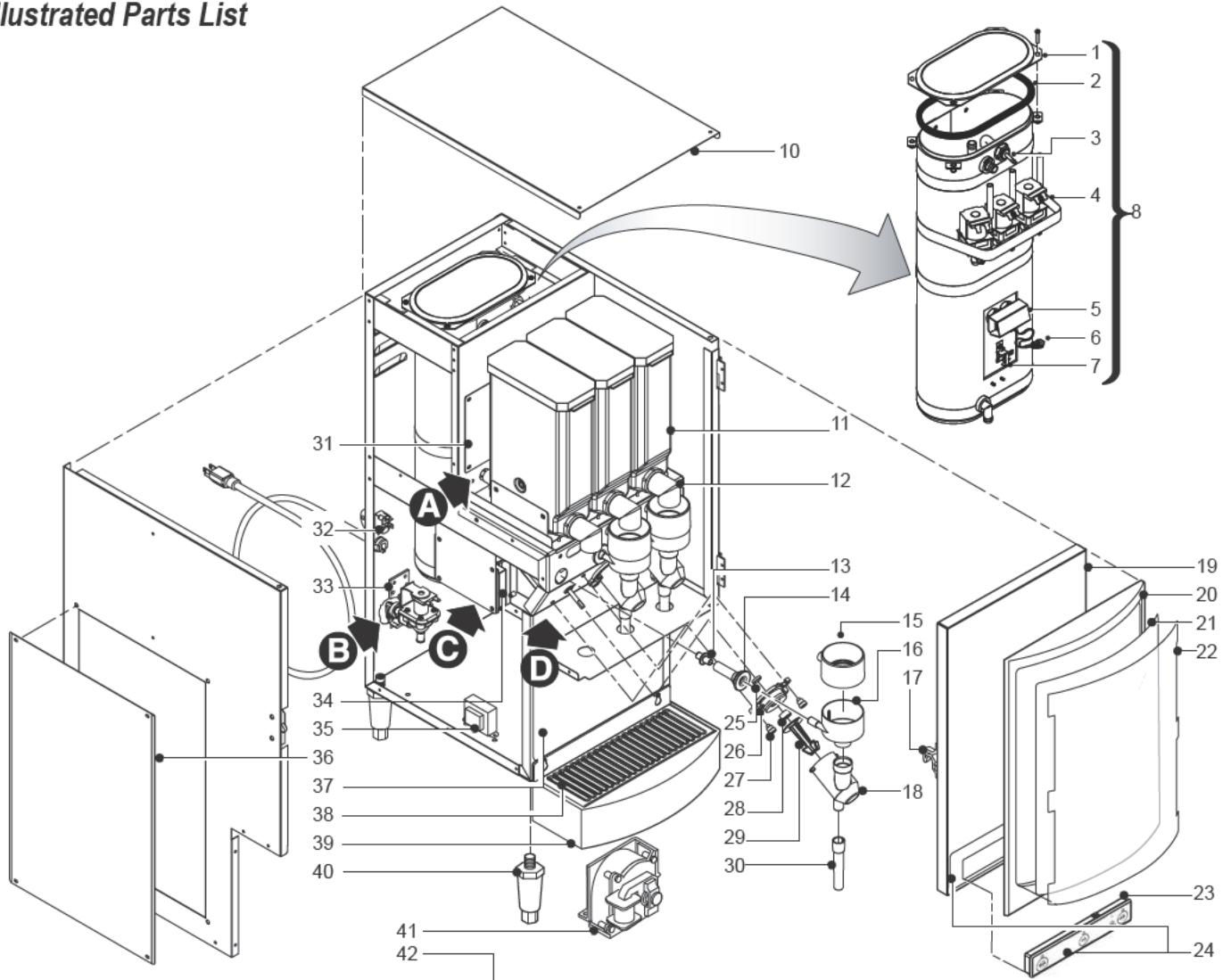

Hot Chocolate	Original Cappuccino	Iced Cappuccino	Almond Amaretto	Russian Tea
Chocolate Malt	Cinnamon Vanilla Malt	Vanilla Malt	English Toffee	Raspberry Malt
Vanilla Cream	French Vanilla	Tea Time French Vanilla	English Toffee	Tea Time French Vanilla
White Chocolate Caramel	French Vanilla	Flavor of the Day	Original Cappuccino	Chai

169 700, WC3102-01

English Toffee	Original Cappuccino	Iced Cappuccino	Almond Amaretto
Banana Nut	Chocolate Mint	Cinnamon Vanilla Nut	Hazelnut
Irish Cream	Raspberry Mocha	Vanilla Cream	French Vanilla
Fat Free French Vanilla	English Toffee	Chai	English Toffee
Hot Chocolate	Original Cappuccino	Iced Cappuccino	Almond Amaretto
Banana Nut	Chocolate Mint	Cinnamon Vanilla Nut	Hazelnut
Irish Cream	Raspberry Mocha	Vanilla Cream	French Vanilla
Hot Chocolate	Fat Free French Vanilla	White Chocolate Caramel	Chai
Banana Nut	Chocolate Mint	Cinnamon Vanilla Nut	English Toffee
Irish Cream	Raspberry Mocha	Vanilla Cream	French Vanilla

WC 3102 01

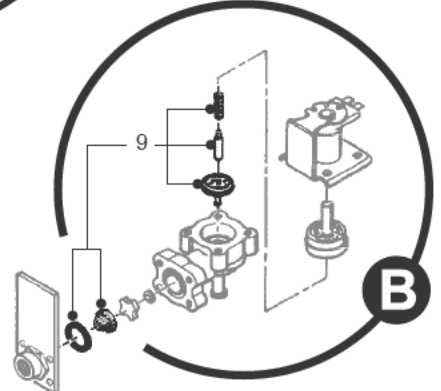
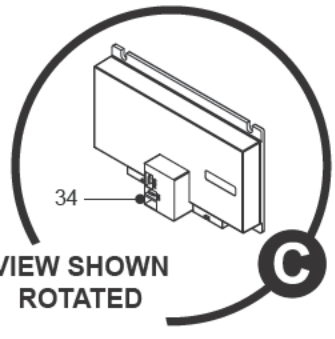
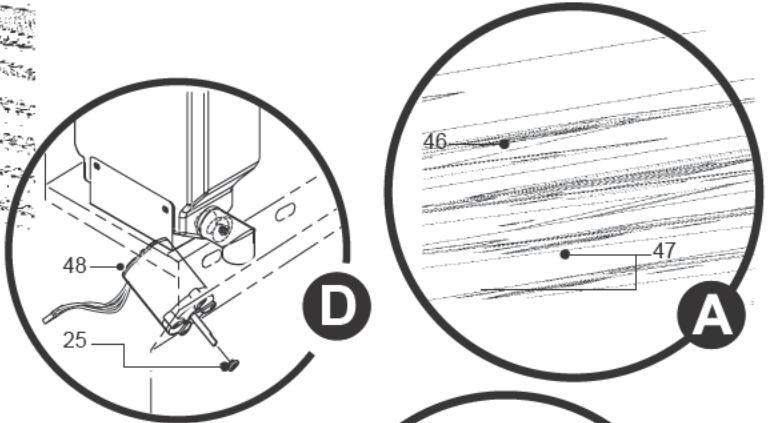

Illustrated Parts List Light Box Option

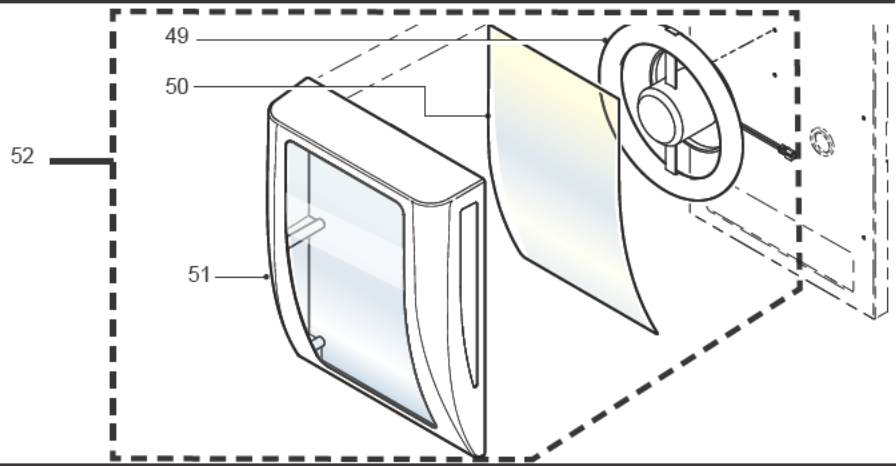

Illustrated Parts List

Item N ^o	Part N ^o	Description	Item N ^o	Part N ^o	Description
1	WC-5853-102	COVER, TOP HEATING TANK GEN USE	24C	WC-39500	LABEL, ASSY CNTRL PNL & OUTER CAFE PC4
1A	WC-5851	COVER, TANK (FOR UNITS BEFORE 3/08)	25	WC-43791*	RING, MOTOR SHAFT PLASTIC
2	WC-43062 *	GASKET, TANK LID	26	WC-37118*	KIT, WHIPPER PLATE (3/PKG)
3	WC-37278 *	KIT, LIQUID LEVEL PROBE GT	27	CA-1024-05 *	PILLAR, LOCATION BLACK
4	WC-3734 *	KIT, DUMP VALVE 120V 12W	28	CA-1076-04	SEAL, WHIPPER PLATE 20/PKG
5	WC- 904-04*	HEATING ELEMENT 1600W 120V W/JMNU	29	CA-1008-07K*	KIT, PROPELLER WHIPPER 6/PKG OFFSET BLD
6	WC-1438-101 *	SENSOR, TEMPERATURE TANK	30	CA-1037-3Y*	TUBE, EXTENSION YELLOW
7	WC- 521 *	SWTICH, #4680 VESSEL LIMIT	31	WC-58142	COVER, DUMP VALVES CAFEP1/2
8	WC-62019	TANK COMPLETE, CAFE PC1	31A	WC-58126	COVER, DUMP VALVES CAFE PC3/4
8A	WC-62020	TANK COMPLETE, CAFE PC2	32	WC- 102*	SWITCH, TOGGLE NON-LIT 25A 120/240VAC
8B	WC-6291	TANK COMPLETE, CAFE PC3	33	WC- 826L *	VALVE, INLET 1GPM 120V 10W
8C	WC-62021	TANK COMPLETE, CAFE PC4	34	WC- 782K	CONTROL POWER MODULE CAFE PC
9	WC-3765L*	KIT, INLET VALVE REPAIR USE ON WC-826L	35	WC- 718-101	TRNSFRMR ASSY, 240/120VAC-12VAC 500mA
10	WC-58137	COVER, TOP CAFE PC1/2	36	WC-58127	COVER, SIDE ACCESS CAFE PC ALL
10A	WC-7389	COVER, TOP CAFE PC3	37	WC-38295	LABEL, SPLASH PANEL CAFE PC1
10B	WC-58151	COVER, TOP CAFE PC4	37A	WC-38338	LABEL, SPLASH PANEL CAFE PC2
11	CA-1111-06	CANISTER ASSY 4LB CAFEP2/3/4	37B	WC-38288	LABEL, SPLASH PANEL CAFE PC3
11A	CA-1124-05	CANISTER ASSY 7LB CAFEP1	37C	WC-38294	LABEL, SPLASH PANEL CAFE PC4
12	CA-1026-03	ELBOW, CANSITER	38	WC-66032	SCREEN, DRIP TRAY CAFE PC 1/2
13	CA-1095	CONNECTOR, ORIFICE WATER	38A	WC-66033	SCREEN, DRIP TRAY CAFE PC3
14	CA-1011-05	BULKHEAD, WATER FITTING	38B	WC-66034	SCREEN, DRIP TRAY CAFE PC4
15	CA-1005-03 *	STEAM TRAP	39	WC-66035	PAN, DRIP TRAY PLASTIC CAFE PC 1/2
16	CA-1009-03 *	MIXING BOWL	39A	WC-66037	PAN, DRIP TRAY PLASTIC CAFE PC 4
17	CA-1135	LATCH ASSEMBLY DOOR SIDE MOUNT	39B	WC-66040	DRIP TRAY & SCREEN ASSY, CAFE PC3
18	CA-1006-06 *	CHAMBER, WHIPPER OFFSET PCGTs	40	WC-3504*	LEG, ADJUSTABLE BLACK
19	WC-58185	DOOR COMPLETE, CAFE PC1	41	WC-37123	FAN, EXTRACT 120V 29 CFM & BRACKET
19A	WC-58186	DOOR COMPLETE, CAFE PC2	42	CA-1030-19*	HOSE, EXTRACTOR FAN 19"L CAFEP2/3/4
19B	WC-58187	DOOR COMPLETE, CAFE PC3	42A	CA-1030-17*	HOSE, EXTRACTOR FAN 17" LONG CAFEP1
19C	WC-58188	DOOR COMPLETE, CAFE PC4	43	WC-5310 *	TUBING, 5/16" ID x 1/8" W SILICONE
20	CA-1129	COVER, DOOR SKIN CAFE PC1/2	44	WC-39105-02	LABEL, FLAVOR LOW TACK DOOR
20A	CA-1130	COVER, DOOR SKIN CAFE PC3	45	WC-39107-02	LABEL, ADHESIVE CANISTER
20B	CA-1131	COVER, DOOR SKIN CAFE PC4	46	WC-37174*	KIT, GEAR MOTOR & GEAR
21	WC-39613	GRAPHIC, CURTIS CAFEP1 GNRC NON-LIT	47	CA-1036*	GEAR, PLASTIC
21A	WC-39455	GRAPHIC, DOOR CURTIS LOGO CAFEP1 & 2	48	WC-3739*	WHIPPING MOTOR
21B	WC-39456	GRAPHIC, DOOR CURTIS LOGO CAFE PC3	49	CA-1127*	LAMP ASSEMBLY, 30W
21C	WC-39457	GRAPHIC, DOOR CURTIS LOGO CAFE PC4	50	WC-39481	FILM, LIGHT BOX CAFE PC1 & CAFE PC2
21D	WC-39493	GRAPHIC, DOOR HOT CHOC/CAFPC1&2 (OPTNL)	50A	WC-39483	FILM, LIGHT BOX CAFE PC3
21E	WC- 39633	GRAPHIC, DOOR ICED CAP CAFEP3	50B	WC-39482	FILM, LIGHT BOX CAFE PC4
22	CA-1134	WINDOW, CLEAR CAFE PC4	50C	WC-39611	FILM, LIGHT BOX CAFE PC1 GENERIC
22A	CA-1133	WINDOW, CLEAR CAFE PC3	50D	WC-39594	FILM, LIGHT BOX HOT CHOC/PC1&2 (OPTNL)
22B	CA-1132	WINDOW, CLEAR CAFE PC1/2	51	CA-1137	LIGHT BOX ASSY, CAFE PC1/2
23	WC- 722K	PANEL, SW 120V CAFE PC3 (W/SMART CARD)	51A	CA-1138	LIGHT BOX ASSY, CAFE PC3
23A	WC- 732	PANEL, SWITCH 120V CAFE PC1/2/4	51B	CA-1139	LIGHT BOX ASSY, CAFE PC4
23B	WC- 722-101	PANEL, 4 BTN 4LED 6 PN CAFEP3 (OLD UNIT)	52	WC-37272	KIT, ADD-ON LIGHT BOX ASSY CAFEP1/PC2
24	WC-39497	LABEL, ASSY CNTRL PNL & OUTER CAFE PC1	52A	WC-37234	KIT, ADD-ON LIGHT BOX ASSY CAFE PC3
24A	WC-39498	LABEL, ASSY CNTRL PNL & OUTER CAFE PC2	52B	WC-37273	KIT, ADD-ON LIGHT BOX ASSY CAFE PC4
24B	WC-39499	LABEL, ASSY CNTRL PNL & OUTER CAFE PC3			

* Suggested Parts to Stock

Electrical Diagram

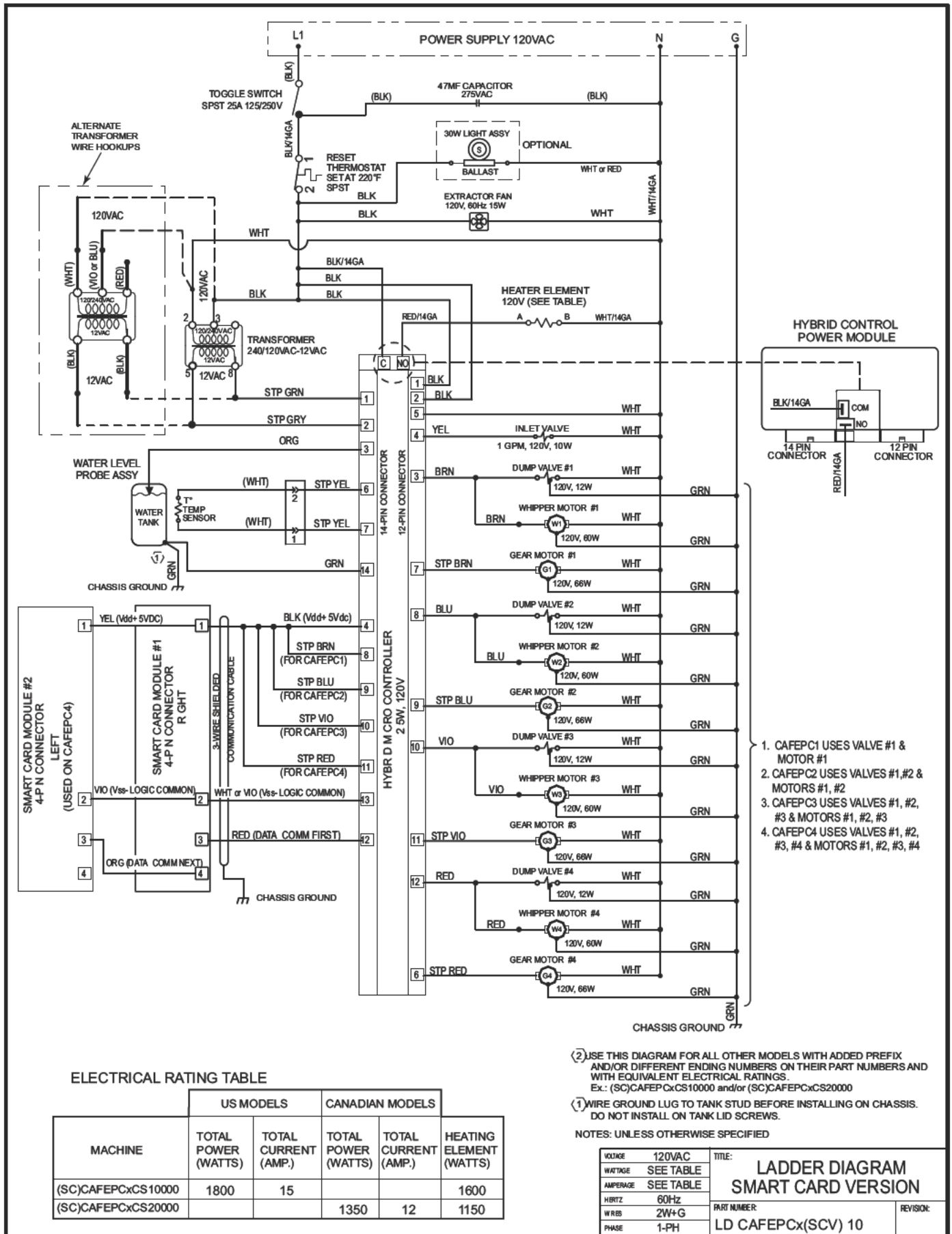

Product Warranty Information

The Wilbur Curtis Company certifies that its products are free from defects in material and workmanship under normal use. The following limited warranties and conditions apply:

3 Years, Parts and Labor, from Original Date of Purchase on digital control boards.

2 Years, Parts, from Original Date of Purchase on all other electrical components, fittings and tubing.

1 Year, Labor, from Original Date of Purchase on all electrical components, fittings and tubing.

Additionally, the Wilbur Curtis Company warrants its Grinding Burrs for Forty (40) months from date of purchase or 40,000 pounds of coffee, whichever comes first. Stainless Steel components are warranted for two (2) years from date of purchase against leaking or pitting and replacement parts are warranted for ninety (90) days from date of purchase or for the remainder of the limited warranty period of the equipment in which the component is installed.

All in-warranty service calls must have prior authorization. For Authorization, call the Technical Support Department at 1-800-995-0417. Effective date of this policy is April 1, 2003.

Additional conditions may apply. Go to www.wilburcurtis.com to view the full product warranty information.

CONDITIONS & EXCEPTIONS

The warranty covers original equipment at time of purchase only. The Wilbur Curtis Company, Inc., assumes no responsibility for substitute replacement parts installed on Curtis equipment that have not been purchased from the Wilbur Curtis Company, Inc. The Wilbur Curtis Company will not accept any responsibility if the following conditions are not met. The warranty does not cover and is void under the following circumstances:

- 1) Improper operation of equipment: The equipment must be used for its designed and intended purpose and function.
- 2) Improper installation of equipment: This equipment must be installed by a professional technician and must comply with all local electrical, mechanical and plumbing codes.
- 3) Improper voltage: Equipment must be installed at the voltage stated on the serial plate supplied with this equipment.
- 4) Improper water supply: This includes, but is not limited to, excessive or low water pressure, and inadequate or fluctuating water flow rate.
- 5) Adjustments and cleaning: The resetting of safety thermostats and circuit breakers, programming and temperature adjustments are the responsibility of the equipment owner. The owner is responsible for proper cleaning and regular maintenance of this equipment.
- 6) Damaged in transit: Equipment damaged in transit is the responsibility of the freight company and a claim should be made with the carrier.
- 7) Abuse or neglect (including failure to periodically clean or remove lime accumulations): Manufacturer is not responsible for variation in equipment operation due to excessive lime or local water conditions. The equipment must be maintained according to the manufacturer's recommendations.
- 8) Replacement of items subject to normal use and wear: This shall include, but is not limited to, light bulbs, shear disks, "O" rings, gaskets, silicone tube, canister assemblies, whipper chambers and plates, mixing bowls, agitation assemblies and whipper propellers.
- 9) Repairs and/or Replacements are subject to our decision that the workmanship or parts were faulty and the defects showed up under normal use. All labor shall be performed during regular working hours. Overtime charges are the responsibility of the owner. Charges incurred by delays, waiting time, or operating restrictions that hinder the service technician's ability to perform service is the responsibility of the owner of the equipment. This includes institutional and correctional facilities. The Wilbur Curtis Company will allow up to 100 miles, round trip, per in-warranty service call.

RETURN MERCHANDISE AUTHORIZATION: All claims under this warranty must be submitted to the Wilbur Curtis Company Technical Support Department prior to performing any repair work or return of this equipment to the factory. All returned equipment must be repackaged properly in the original carton. No units will be accepted if they are damaged in transit due to improper packaging. NO UNITS OR PARTS WILL BE ACCEPTED WITHOUT A RETURN MERCHANDISE AUTHORIZATION (RMA). RMA NUMBER MUST BE MARKED ON THE CARTON OR SHIPPING LABEL. All in-warranty service calls must be performed by an authorized service agent. Call the Wilbur Curtis Technical Support Department to find an agent near you.



WILBUR CURTIS CO., INC.

6913 Acco St., Montebello, CA 90640-5403 USA

Phone: 800/421-6150 – Fax: 323-837-2410

– Technical Support Phone: 800/995-0417 (M-F 5:30A - 4:00P PST) – E-Mail: techsupport@wilburcurtis.com

– Web Site: www.wilburcurtis.com

FOR THE LATEST SPECIFICATION INFORMATION GO TO WWW.WILBURCURTIS.COM