



CAFE PRIMO CAPPUCCINO SYSTEMS

MODELS: CAFE PC1, CAFE PC2, CAFE PC3,
CAFE PC3 ICED CAPPUCCINO, CAFE PC4

Sometimes simple
is the perfect fit.

ITEM NO _____

PROJECT _____

DATE _____

Customize your own cappuccino machine

Easily interchangeable non
lighted graphic can be
custom printed with any
quality printer or at a local
copy center.



Curtis Cafe Series Primo Cappuccino Machine

Now any operation can offer profitable and delicious cappuccino beverages.

Enrich your profits while delighting your customers with the beautifully styled Café Primo Cappuccino machine from Curtis. You don't need large volume or big counters to make the Café PC a highly profitable success.

CUSTOMERS will love the rich flavor and fast service.

YOUR STAFF will be pleased with the easy operation and maintenance.

YOU will appreciate the affordable price, great reliability, and profits.

The compact Curtis Café PC offers commercial quality at an exceptional value. Café PC models share many critical components with Curtis' Generation Three Primo Cappuccino Systems, so you get all the benefits of a professional machine without the high-end features you may not need. And, the Café PC is available in multiple drink models for maximum flexibility.

Step up to rich cappuccino dispensing and start earning robust profits from the first day with the Café PC from Curtis.

FEATURES AT A GLANCE

- **Fits Anywhere.** The Café PC's compact size lets you place it virtually anywhere. A close water connection and standard 120VAC power allows use of any available outlet.
- **Low Maintenance Costs.** The key components that ensure reliable operation in the Café PC are same heavy-duty components used in our top-of-the-line PCGT models, so you don't have to compromise with a less expensive machine. Plus, many components are shared across all four models within the Cafe Series.
- **Consistent Drink Quality.** Café models utilize Curtis' proven advanced ADS™ digital control module that allows precision blending for consistently great beverages. Powder-to-water ratio is set right from the front panel, so there's never a need to manually adjust internal valves. Plus, Café series machines can be set for continuous or portion control dispensing.
- **Designed to Keep Profits Flowing.** From the drip tray to the removable powder hoppers, the Café PC is designed for quick, mess-free servicing without special training.
- **Flexible Design.** Its easily changeable display graphic lets you customize and switch messages anytime you want.
- **Backed by Curtis.** You have the confidence of owning a quality product engineered by Curtis, a family-owned company with a 60-year heritage in the convenience store industry.



CAFE PC1*

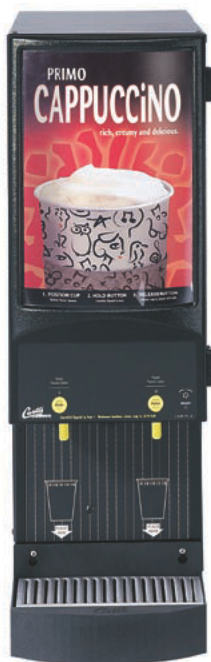

CAFE PC2*



CAFE PC3 ICED CAPPUCCINO

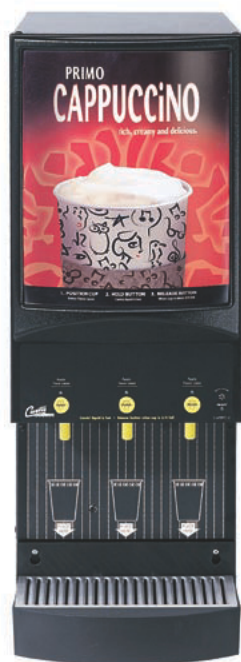

CAFE PC3



CAFE PC4

*Optional Hot Chocolate Display Graphic Available (WC-39493)

Quality, Commercial Grade Components



Angled Whipping Chamber and High-Velocity Whipping Motors

Angled chamber is compact and drains liquids efficiently to significantly reduce cleaning requirements. Sloped whipping motor ensures complete blending of powder and water without build-up.

“Brake-Type” Auger Motors

To ensure perfect drinks, powder augers feature a brake-type motor that accurately stops the dispensing process at your set ratio every time.

Standardized 4-lb. Hoppers (7 lb. on Cafe PC1)

Double up flavors on popular drinks to minimize fill time. Hoppers must be removed for refilling, virtually eliminating machine downtime caused by spilled powder inside the machine. Positioning guides ensure proper hopper placement.



One-Touch Hot Water Cleaning System

Sends a powerful blast of hot water into the whipping chamber, rinsing it for easy clean-up and reducing powder build-up.



Digitally Adjustable Power-to-Water Ratio

Easily set right from the front panel. Individually adjustable by flavor/station to ensure the perfect flavor every time.

“Eyebrow-Styled” Graphic Frame

Attractive curved front enhances the standard display graphic.

Easy-change design allows for your signature message to be created at any local copy center enhancing sales impact. Plus optional back-lighted option garners even more attention.



Standard Drip Tray

Removable drip tray catches any spills to keep counter area clean and tidy.



CAFE PC STANDARD ITEMS

Feature	Café PC Series
Angled whipping chambers	👍
Precision whipping propellers	👍
Sloped high-velocity whipping motors	👍
Brake-type auger motors	👍
Splash-resistant dispensing nozzles	👍
Precision direct-drive mixing system	👍
Extractor fan to remove residual powder	👍
High quality dump valve for water inlet control	👍
One-touch hot water cleaning system	👍
Easy access front door for servicing	👍
120 VAC operation	👍
Precision ADS™ Digital Control	👍
Smooth, Touch Control Dispense Buttons	👍
Shared Control Components Across All Models	👍
3-2-1 Warranty	👍
Easily Interchangeable Graphic	👍
Quick-Remove Drip Tray for Cleaning	👍
Encased Switch Module with Million-Cycle Switches	👍
Removable Hopper Base for Cleaning	👍
Expanded Flavor Label Display Area	👍

Café PC1

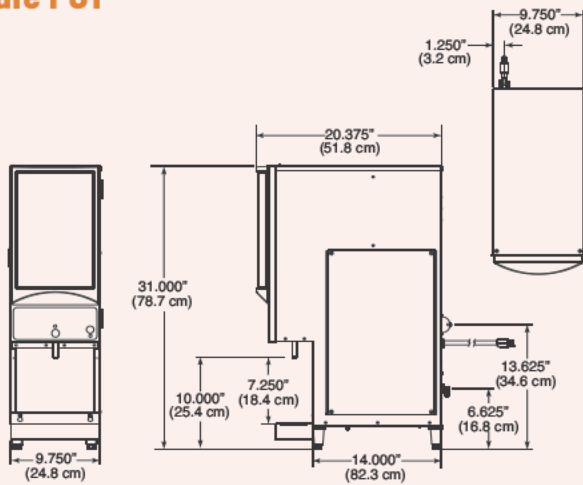

Café PC2

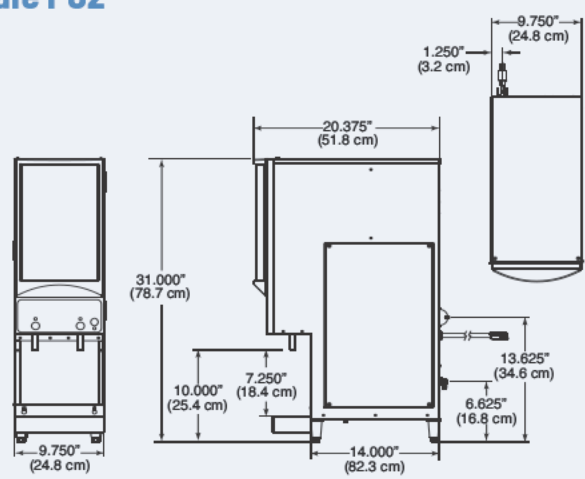

Café PC3

Café PC3 Iced Cappuccino

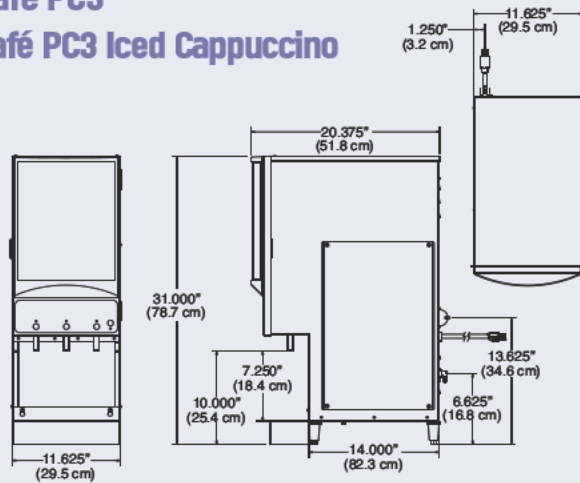

Café PC4

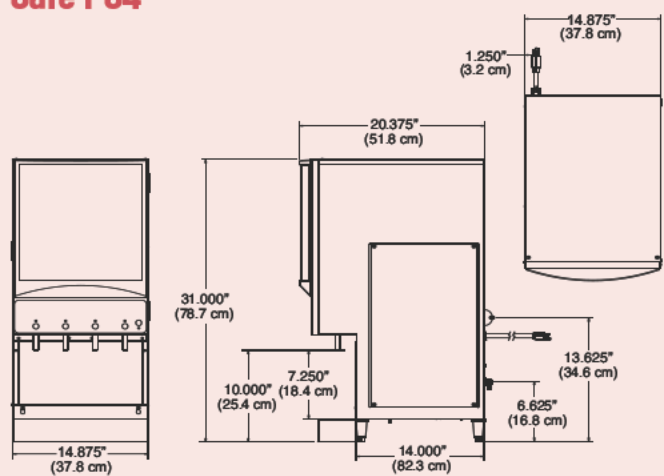

Specifications	Café PC1	Café PC2	Café PC3 Café PC3 Iced Cappuccino	Café PC4
Hoppers	1	2	3	4
Hopper Capacity	7 lbs.	4 lbs.	4 lbs.	4 lbs.
Water Tank	2.01 gal.	2.01 gal.	2.01 gal.	2.01 gal.
Display Graphics	12.5" x 8.625"	12.5" x 8.625"	12.5" x 10.25"	12.5" x 13.625"
Dimensions (HxWxD)	31" x 9.75" x 20.375"	31" x 9.75" x 20.375"	31" x 11.625" x 20.375"	31" x 14.875" x 20.375"
Cup Clearance	7.25"	7.25"	7.25"	7.25"
Voltage	120VAC/60Hz	120VAC/60Hz	120VAC/60Hz	120VAC/60Hz
Power Requirements	1800W/15A	1800W/15A	1800W/15A	1800W/15A
Cord & Plug	6 ft/NEMA 5-15P	6 ft/NEMA 5-15P	6 ft/NEMA 5-15P	6 ft/NEMA 5-15P
Water Inlet	1/4" Flare	1/4" Flare	1/4" Flare	1/4" Flare
Shipping Weight	58 lbs.	62 lbs.	74 lbs.	85 lbs.
Cube (cu.ft.)	6.7	8.2	9.0	10.4



WILBUR CURTIS COMPANY, INC.

6913 Acco Street, Montebello, CA 90640-5403

Telephone: 800-421-6150 · 323-837-2300

Fax: 323-837-2406

www.wilburcurtis.com

