



GEMINI® 1.5 GALLON COFFEE BREWING SYSTEMS

MODEL : GEMSS10A1000, GEMSS63A1000, GEMTS10A1000, GEMTS16A1000, GEMTS19A1000



**GEMSS10A1000/
GEMSS63A1000**
Single Coffee Brewer with
One GEM-3 1.5 Gallon
Satellite Server



**GEMTS10A1000/
GEMTS16A1000/
GEMTS19A1000**
Twin Coffee Brewer with
Two GEM-3 1.5 Gallon
Satellite Servers

Legendary Performance, Incredible Advanced Design – Incredibly Easy to Use.

Gemini® systems are available in both single and twin, designed to optimize coffee quality and flavor, while reducing maintenance and service. The Satellite Servers maintain coffee temperature, preserving the rich and bold flavor for extended periods. On-Board self diagnostics continually sense proper brewing operations and a Service Phone Number and error code are displayed in the event technical assistance is required.

Curtis G3 technology combines precision brewing capability with an easy-to-use interface. All brewing functions are displayed in real time, not a coded system of indicators. Curtis Gemini® systems are factory set for out-of-the box operation with pre-programmed recipes that ensures a consistent brew, every time. And, with scroll-through menus it's just as easy to fine-tune the brewing process for your exacting gourmet coffee profile.

ITEM NO

PROJECT

DATE

FEATURES AT A GLANCE

- **G3 Digital Control Module** - Provides precise control over all aspects of brewing in an intuitive, easy-to-read and operate system.
- **Pre-Set Global Recipes at the Touch of a Single Button** – No complex equipment required.
- **Field Selectable** - One, two or three batch brewing.
- **Enhanced Recovery Circuitry** – Boosts performance on 220V/single phase models.

SATELLITE SERVER AND STAND

- Coffee maintains its rich, full-bodied flavor in double wall insulated servers.
- Brew through lid keeps heat and flavor in.
- Warmers can be set on high, medium or low to preserve peak flavor.
- Standard faucet clearance for cup or decanter service.
- Optional heated serving stands available.
- Satellite safety lids protect against accidental spills.



GEM-3
1.5 Gallon
Satellite Server



GEM-5
Satellite
Warmer Stand

**GEMSS10A1000/
GEMSS63A1000**
Single Coffee Brewer

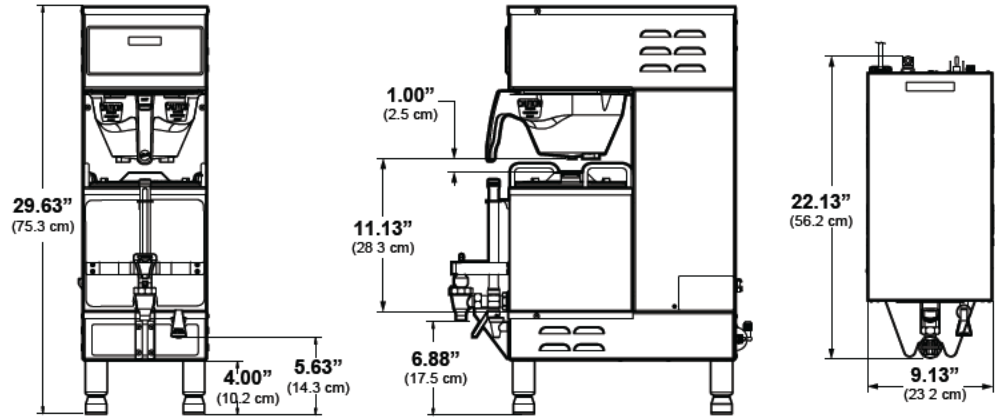

**GEMTS10A1000/
GEMTS16A1000/
GEMTS19A1000**
Twin Coffee Brewer

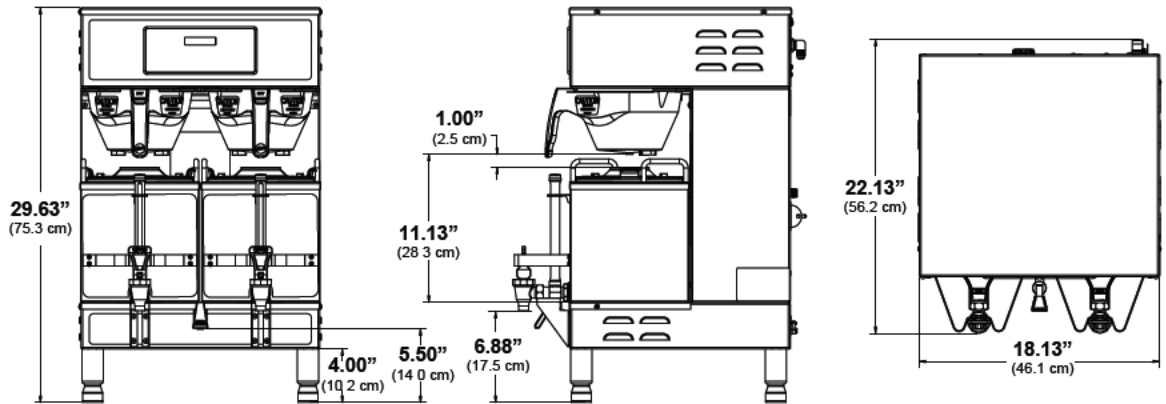

SPECIFICATIONS

MODEL #	DIMENSIONS (H x W x D)	PHASE	VOLTS	AMPS	WIRE	WATTS	HERTZ	GAL/HR	WATER CONNECTOR	SHIP WEIGHT	SHIP CUBE
GEMSS10A1000	29.63" x 9.13" x 22.13"	1.0 PH	220V	19.5A	3W+G	4300W	50/60 Hz	10.5	3/8" Flare	50.0 lbs.	7.0 cu. ft.
GEMSS63A1000	29.63" x 9.13" x 22.13"	1.0 PH	120/220V	15.0/12.7A	2/3W+G	1800/2800W	50/60 Hz	4.5/7.5	3/8" Flare	50.0 lbs.	7.0 cu. ft.
GEMTS10A1000	29.63" x 18.13" x 22.13"	1.0 PH	220V	23.6/35.4A	3W+G	5200/7600W	50/60 Hz	15.0/21.0	3/8" Flare	81.0 lbs.	10.9 cu. ft.
GEMTS16A1000	29.63" x 18.13" x 22.13"	3.0 PH	220V	20.0A	3W+G	7800W	50/60 Hz	21.0	3/8" Flare	93.0 lbs.	10.9 cu. ft.
GEMTS19A1000	29.63" x 18.13" x 22.13"	3.0 PH	220V	20.0A	4W+G	7800W	50/60 Hz	21.0	3/8" Flare	81.0 lbs.	10.9 cu. ft.
GEM-3	10.75" x 9.00" x 13.50"	N/A	N/A	N/A	N/A	N/A	N/A	N/A	N/A	11.0 lbs.	1.36 cu. ft.
GEM-5	9.75" x 9.00" x 11.38"	N/A	120V	1.0A	2W+G	100W	N/A	N/A	N/A	8.0 lbs.	1.36 cu. ft.

SPECIFICATIONS SUBJECT TO CHANGE WITHOUT NOTICE



WILBUR CURTIS COMPANY, INC.
6913 Acco Street, Montebello, CA 90640-5403
Telephone: 800-421-6150 · 323-837-2300
Fax: 323-837-2406
www.wilburcurtis.com



08/2014 - F-3365 rev.C