



**Mechanical
Baker's Dough Scale
Owners Manual**



8525-M292-O1 Rev B
11/09

CARDINAL SCALE MFG. CO.
PO BOX 151 • WEBB CITY, MO 64870
PH (417) 673-4631 • FAX (417) 673-5001
www.detectoscale.com

Printed in USA

Technical Support: Ph: 866-254-8261 • techsupport@cardet.com

PRODUCT SPECIFICATIONS

Model	Capacity	*Scoop and Jar	Weight Pack P/N	Stainless Steel	Enamel	Shipping Weight
1001TB	16 lb	X	1WP100X		X	38 lb
1001TBKG	8 kg	X	1WK200X		X	38 lb
1001TBNS	16 lb		1WP100X		X	38 lb
1002TB	8 lb	X	1WP250X		X	30 lb
1002TBKG	5 kg	X	1WK100X		X	30 lb
1002TBNS	8 lb		1WP250X		X	30 lb
1051TBS	16 lb	X	1WP100X	X		38 lb
1052TBS	8 lb	X	1WP250X	X		30 lb

Cardinal Scale reserves the right to improve, enhance and modify features and specifications without prior notice.

- * All models with Scoop and Jar include:
P/N 6100-0002, SCOOP, PLASTIC.
P/N 6100-0005, JAR W/LID, POLYPROPYLENE.

UNPACKING INSTRUCTIONS

1. Open carton and remove the counterweight, scoop and jar.
2. Cut the inner packing straps and remove the upper cardboard pad.
3. Remove scale from carton. To remove scale, lift up with equal force on the weight plates.
4. Check for any damage incurred in shipping. If the scale has been damaged, place a claim with the carrier. It is the responsibility of the purchaser to file all claims for any damages or loss incurred during transit. Use the original carton and shipping material to return the scale.
5. Remove the lower cardboard pad.
6. Remove weight box (es) from end(s) of main box. To remove weight box (es), pull visible edge of cardboard up. NOTE! You may need to remove staples first.

OPERATING INSTRUCTIONS

Adjusting the Counterweight

1. Unscrew top from counterweight.
2. Place counterweight, top and scale pan on respective sides.
3. Fill counterweight with sugar or salt until balance is achieved.
4. Secure top to counterweight.

To Move Poise

To move poise, lift up to clear notches on beam and slide to desired position and release.

CARE AND CLEANING OF SCALE

- DO NOT subject the weight plates to sudden shocks.
- DO NOT use abrasive cleaners, acetone or other volatile solvents for cleaning scale.
- DO clean the scale using a damp soft cloth and mild detergent.
- DO avoid areas where the scale might be exposed to moisture.

PARTS IDENTIFICATION

Models 1001TB, 1001TB-X, 1001TBNS, 1002TB and 1002TBNS

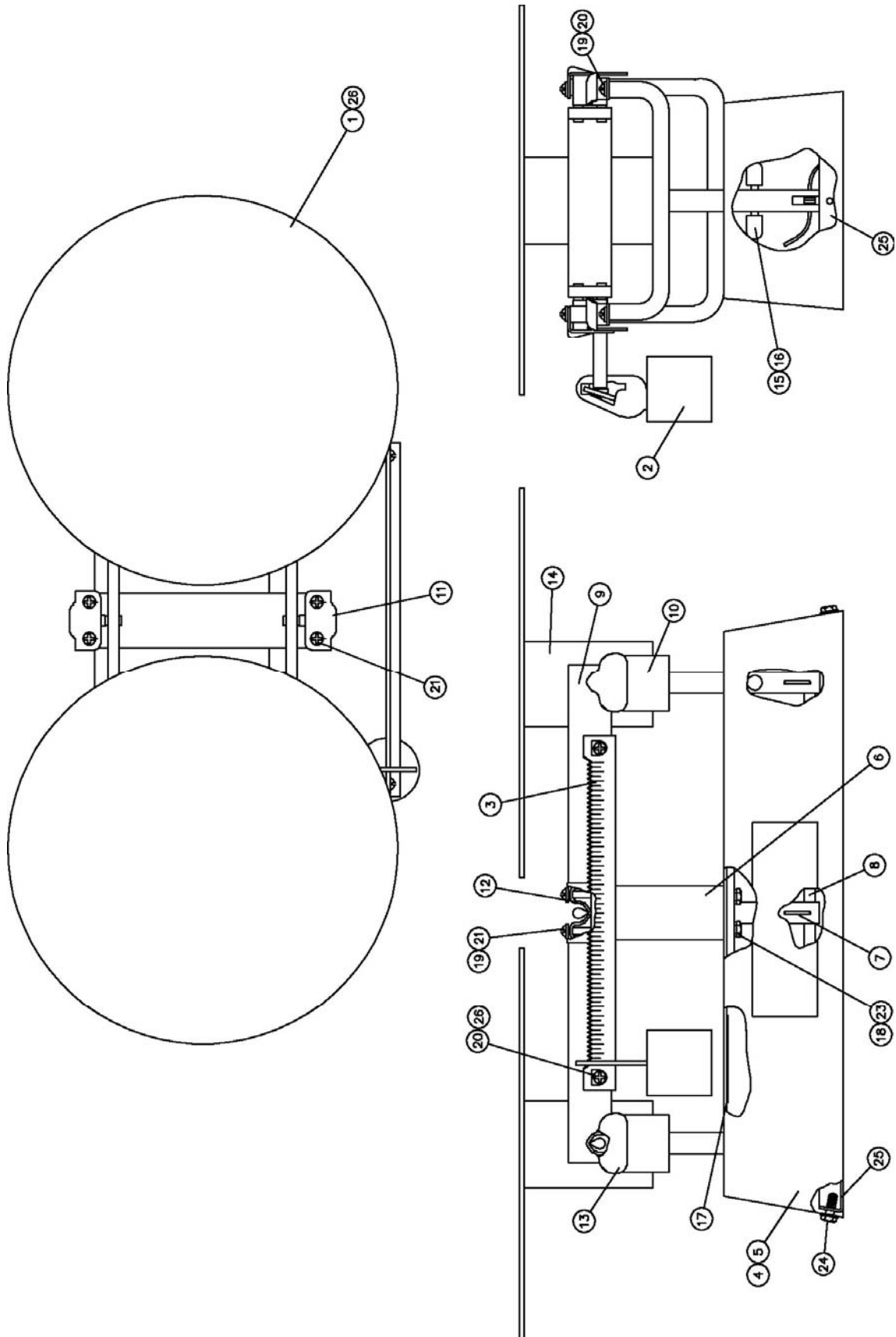

PARTS IDENTIFICATION, CONT.

Models 1001TB, 1001TB-X, 1001TBNS, 1002TB and 1002TBNS

.001	.001	26	6560-0021	LOCTITE	#222-31 LO-STRENGTH
1	-	25	2E2005	BOTTOM COVER	
2	-	24	6021-0985	SCREW HEX/WASHER	#10-32 X .500 SHEET METAL
2	2	23	6021-0988	SCREW HEX HD	#10-32 X .500
.
4	4	21	6021-0839	SCREW RD HD	#8-32 X .875
10	10	20	6021-0822	SCREW, RD HD	#8-32 X .375 PHIL DRIVE
12	12	19	6024-1000	WASHER, LOCK	#8 INTERNAL TOOTH
2	2	18	6024-0033	WASHER, LOCK	#10
1	1	17	593GR986	SERIAL TAG ASSY	
4	4	16	6540-1051	RUBBER TIP	5/32" ID X 23/64" OD X 17/32" LG
2	2	15	2E2068	BUMPER PIN	
2	2	14	3E2014X	SHOT CUP WELDMENT	
4	4	13	4E88	END YOKE BEARING	
2	2	12	4E87	CENTER YOKE BEARING	
2	2	11	2E80	SIDE CAP	
2	2	10	2E2008X	END YOKE ASSY	
1	1	9	2E4002X	LEVER ASSEMBLY	
2	2	8	2E34	TOGGLE BAR	
3	3	7	20B1068	TOGGLE PIN	
1	1	6	2E2012X	CENTER YOKE ASSY	
1	-	5	2E2001X-2	BASE WELDMENT	
-	1	4	2E2001X	BASE WELDMENT	
1	1	3	2E33	SIDE BEAM	
1	1	2	1E3204X	POISE	
2	2	1	1E13X	WEIGHT PLATE ASSY	
QTY.	QTY.	ITEM	PART NUMBER	DESCRIPTION	MATERIAL OR SOURCE
2E6100X	2E6000X	ASSY			

PARTS IDENTIFICATION, CONT.

Models 1001T2B, 1001T2BNS, 1002T2B and 1002T2BNS

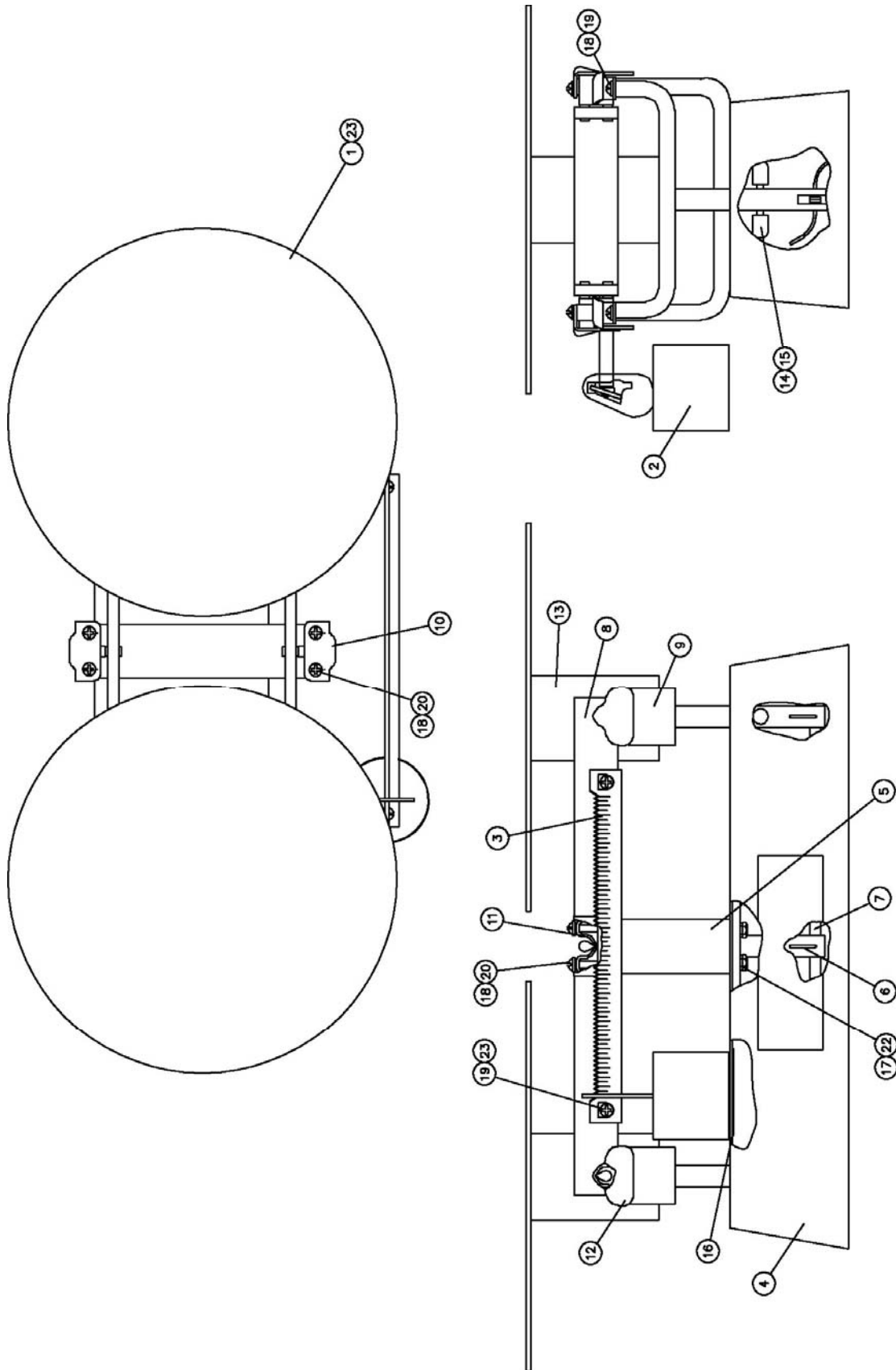

PARTS IDENTIFICATION, CONT.

Models 1001T2B, 1001T2BNS, 1002T2B and 1002T2BNS

.001	23	6560-0021	LOCTITE	#222-31 LO-STRENGTH
2	22	6021-0988	SCREW HEX HD	#10-32 X .500
.
4	20	6021-0839	SCREW RD HD	#8-32 X .875
10	19	6021-0822	SCREW, RD HD	#8-32 X .375 PHIL DRIVE
12	18	6024-1000	WASHER, LOCK	#8 INTERNAL TOOTH
2	17	6024-0033	WASHER, LOCK	#10
1	16	593GR986	SERIAL TAG ASSY	
4	15	6540-1051	RUBBER TIP	5/32" ID X 23/64" OD X 17/32" LG
2	14	2E2068	BUMPER PIN	
2	13	3E2014X	SHOT CUP WELDMENT	
4	12	4E88	END YOKE BEARING	
2	11	4E87	CENTER YOKE BEARING	
2	10	2E80	SIDE CAP	
2	9	2E2008X	END YOKE ASSY	
1	8	2E4002X	LEVER ASSEMBLY	
2	7	2E34	TOGGLE BAR	
3	6	20B1068	TOGGLE PIN	
1	5	2E2012X	CENTER YOKE ASSY	
1	4	2E2001X	BASE WELDMENT	
1	3	1E4033	SIDE BEAM	
1	2	1E4204X	POISE	
2	1	1E13X	WEIGHT PLATE ASSY	
QTY.	ITEM	PART NUMBER	DESCRIPTION	MATERIAL OR SOURCE
2E8000X	ASSY			

PARTS IDENTIFICATION, CONT.

Models 1001TBKG, 1002TBKG

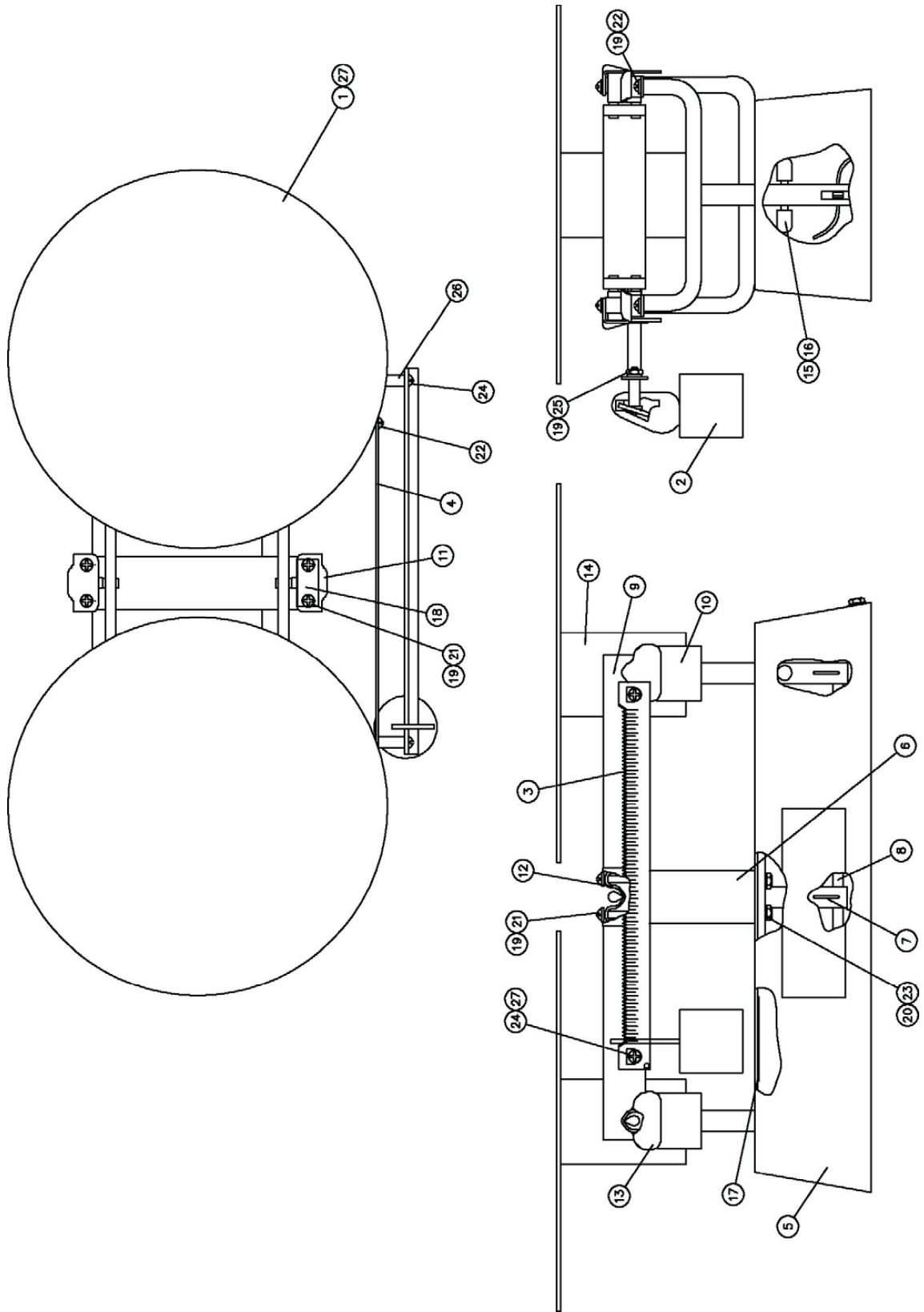

PARTS IDENTIFICATION, CONT.

Models 1001TBKG, 1002TBKG

.001	27	6560-0021	LOCTITE	222-31 LO-STRENGTH
2	26	1E705	SPACER	
1	25	6013-0255	HEX NUT	#8-32
2	24	6021-0790	SCREW RD HD	#8-32 X 1.00
2	23	6021-0988	SCREW HEX HD	#10-32 X .500
9	22	6021-0822	SCREW, RD HD	#8-32 X .375 PHIL DRIVE
4	21	6021-0839	SCREW RD HD	#8-32 X .875
2	20	6024-0033	WASHER, LOCK	#10
13	19	6024-1000	WASHER, LOCK	#8 INTERNAL TOOTH
1	18	2E263	SERIAL NO. PLATE	
1	17	593GR986	SERIAL TAG ASSY	
4	16	6540-1051	RUBBER TIP	5/32" ID X 23/64" OD X 17/32" LG
2	15	2E2068	BUMPER PIN	
2	14	3E2014X	SHOT CUP WELDMENT	
4	13	4E88	END YOKE BEARING	
2	12	4E87	CENTER YOKE BEARING	
2	11	2E80	SIDE CAP	
2	10	2E2008X	END YOKE ASSY	
1	9	2E4002X	LEVER ASSEMBLY	
2	8	2E34	TOGGLE BAR	
3	7	20B1068	TOGGLE PIN	
1	6	2E2012X	CENTER YOKE ASSY	
1	5	2E2001X	BASE WELDMENT	
1	4	2E70	READING BRACKET	
1	3	5D247	SIDE BEAM	
1	2	1E3204X	POISE	
2	1	1E13X	WEIGHT PLATE ASSY	
QTY.	ITEM	PART NUMBER	DESCRIPTION	MATERIAL OR SOURCE
2E7000X	ASSY			

PARTS IDENTIFICATION, CONT.

Models 1051TBS, 1051TBSNS, 1051TBSNSW,
1051TBS-X, 1051T2BSNS and 1052TBS

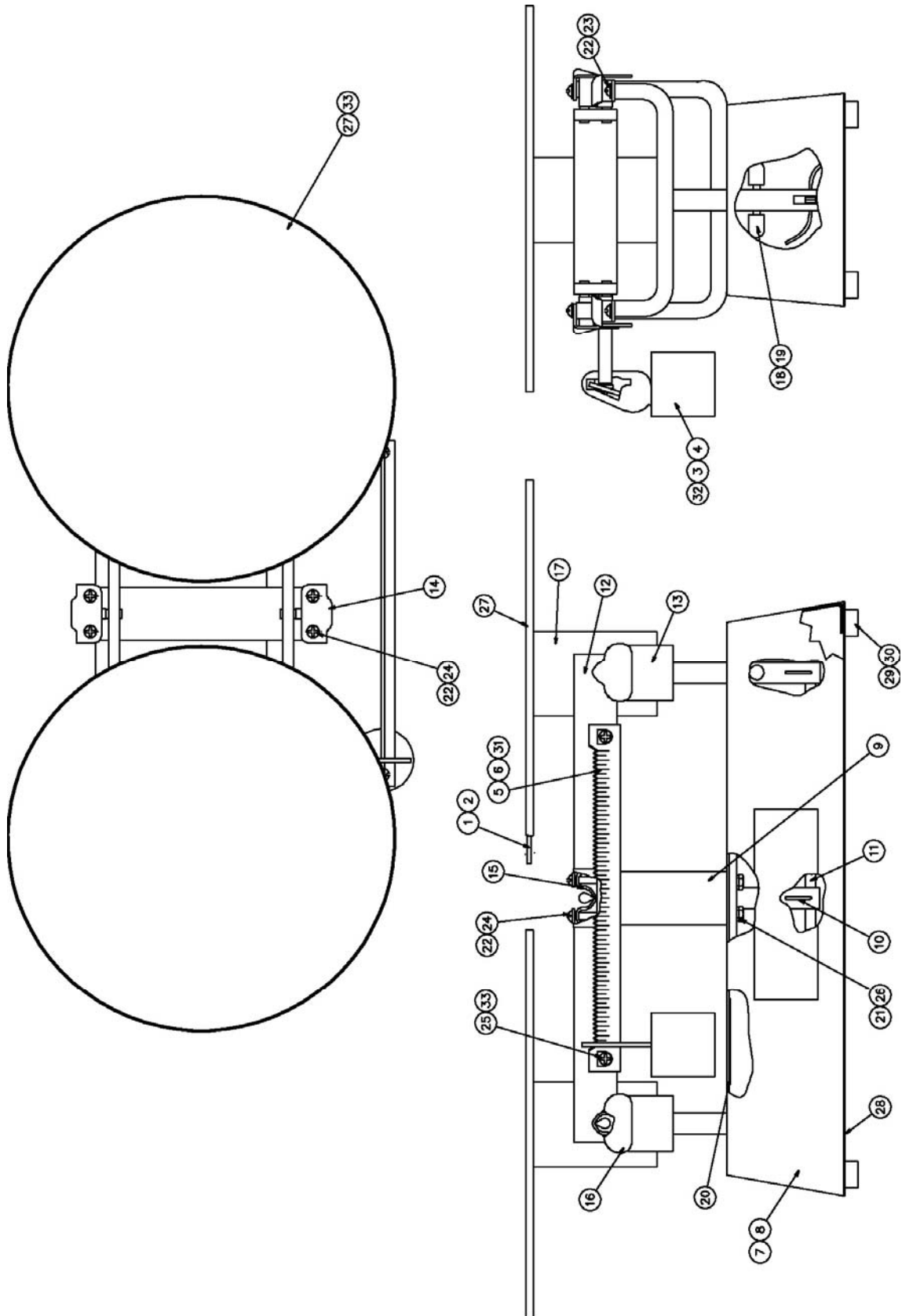

PARTS IDENTIFICATION, CONT.

**Models 1051TBS, 1051TBSNS, 1051TBSNSW,
1051TBS-X, 1051T2BSNS and 1052TBS**

.001	.001	.001	33	6560-0021	LOCTITE	222-31 LO-STRENGTH
1	-	-	32	1E5204X	POISE ASS'Y.	S.S. 2 lb.
1	-	-	31	1E3033	READ BEAM	S.S. 2 lb.
4	4	4	30	6021-0106	SCREW, PAN HD	#6-32 X .375 SS SELF TAP
4	4	4	29	6540-1057	RUBBER FOOT	.62 DIA. X .31 HIGH
-	-	1	28	1E2005	BOTTOM COVER	
-	-	-	27	1E1013X	COVER PLATE	S.S. COVER FOR 1E13X WT. PLATE
2	2	2	26	6021-0988	SCREW HEX HD	#10-32 X .500
2	2	2	25	6021-0876	SCREW, RD HD	#8-32 X .375 PHIL DRIVE S.S.
4	4	4	24	6021-0839	SCREW RD HD	#8-32 X .875
8	8	8	23	6021-0822	SCREW RD HD	#8-32 X .375 PHIL DR
12	12	12	22	6024-1000	WASHER, LOCK	#8 INTERNAL TOOTH
2	2	2	21	6024-0033	WASHER, LOCK	#10
1	1	1	20	593GR986	SERIAL TAG ASSY	
4	4	4	19	6540-1051	RUBBER TIP	5/32" ID X 23/64" OD X 17/32" LG
2	2	2	18	2E2068	BUMPER PIN	
2	2	2	17	3E3014X	SHOT CUP WELDMENT	
4	4	4	16	4E88	END YOKE BEARING	
2	2	2	15	4E87	CENTER YOKE BEARING	
2	2	2	14	2E80	SIDE CAP	
2	2	2	13	2E5008X	END YOKE ASSY	
1	1	1	12	2E5002X	LEVER ASSEMBLY	
2	2	2	11	2E34	TOGGLE BAR	
3	3	3	10	20B1068	TOGGLE PIN	
1	1	1	9	2E5012X	CENTER YOKE ASSY	
-	-	-	8	2E2001X	BASE WELDMENT	
1	1	1	7	1E2201X	BASE WELDMENT	
-	-	-	6	2E33	SIDE BEAM	
-	1	1	5	1E2033	SIDE BEAM	
-	-	-	4	1E3204X	POISE	
-	1	1	3	1E2204X	POISE	
-	-	-	2	1E13X	WEIGHT PLATE ASSY	
2	2	2	1	1E2013X	WEIGHT PLATE ASSY	
QTY.	QTY.	QTY.	ITEM	PART	DESCRIPTION	MATERIAL OR
2E9300X-1	2E9300X	2E9000X	ASSY	NUMBER		SOURCE

PARTS IDENTIFICATION, CONT.

Models 1051TBSKG, 1051TBS-XKG, 1052TBSKG

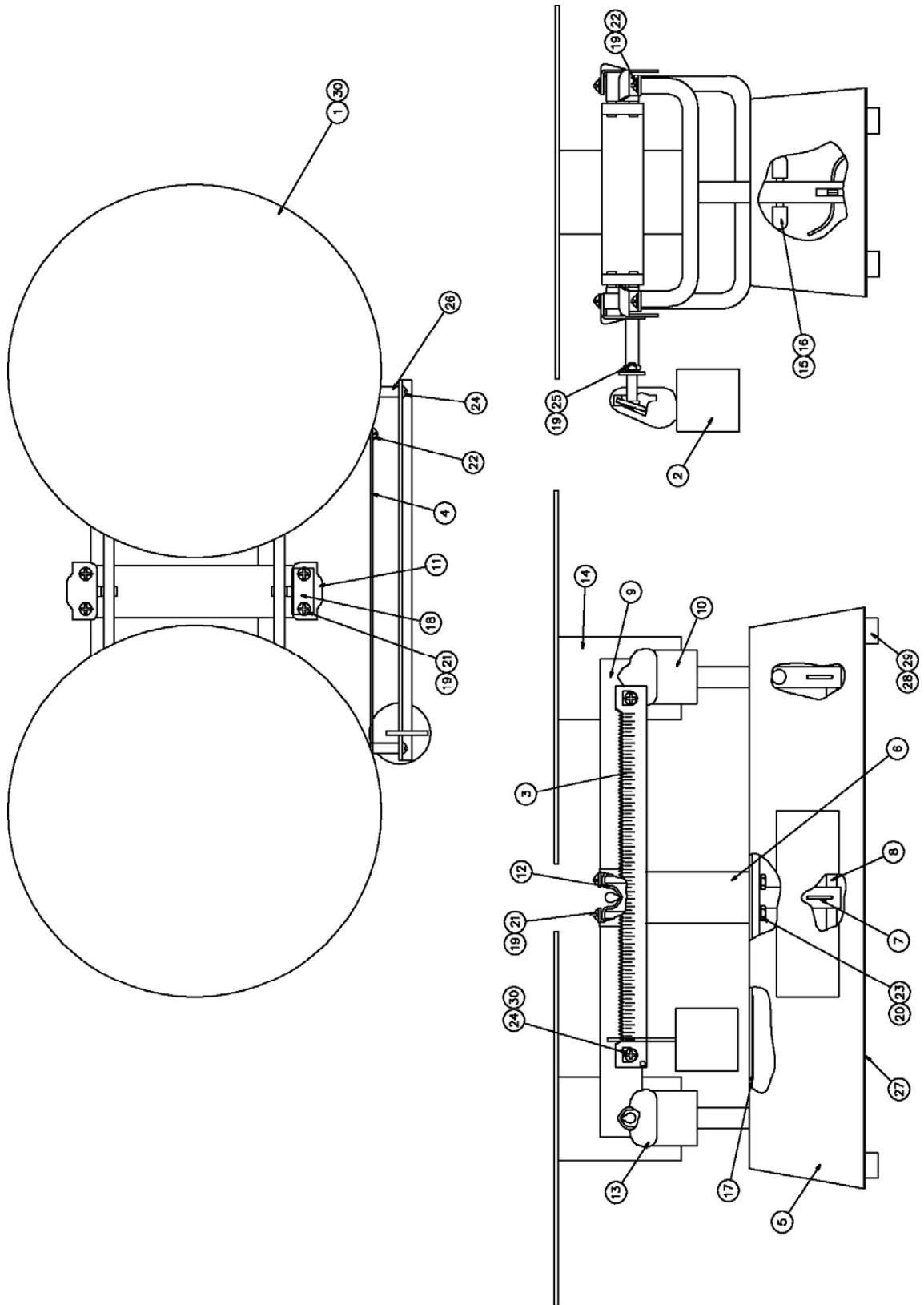

PARTS IDENTIFICATION, CONT.

Models 1051TBSKG, 1051TBS-XKG, 1052TBSKG

.001	.001	30	6560-0021	LOCTITE	222-31 LO-STRENGTH
	4	29	6021-0106	SCREW, PAN HD	#6-32 X .375 SELF TAPPING
	4	28	6540-1057	RUBBER FOOT	.62 DIA. X .31 HIGH
	1	27	1E2005	COVER PLATE	
2	2	26	2E9705	SPACER	
1	1	25	6013-0027	HEX NUT	#8-32 SS
2	2	24	6021-1015	SCREW RD HD	#8-32 X 1.00 PHIL DR SS
2	2	23	6021-0988	SCREW HEX HD	#10-32 X .500
9	9	22	6021-0822	SCREW, RD HD	#8-32 X .375 PHIL DRIVE
4	4	21	6021-0839	SCREW RD HD	#8-32 X .875
2	2	20	6024-0033	WASHER, LOCK	#10
13	13	19	6024-1000	WASHER, LOCK	#8 INTERNAL TOOTH
1	1	18	2E263	SERIAL NO. PLATE	
1	1	17	593GR986	SERIAL TAG ASSY	
4	4	16	6540-1051	RUBBER TIP	5/32" ID X 23/64" OD X 17/32" LG
2	2	15	2E2068	BUMPER PIN	
2	2	14	3E3014X	SHOT CUP WELDMENT	
4	4	13	4E88	END YOKE BEARING	
2	2	12	4E87	CENTER YOKE BEARING	
2	2	11	2E80	SIDE CAP	
2	2	10	2E5008X	END YOKE ASSY	
1	1	9	2E5002X	LEVER ASSEMBLY	
2	2	8	2E34	TOGGLE BAR	
3	3	7	20B1068	TOGGLE PIN	
1	1	6	2E5012X	CENTER YOKE ASSY	
1	1	5	1E2201X	BASE WELDMENT	
1	1	4	2E9170	READING BRACKET	
1	1	3	2E9247	SIDE BEAM	
1	1	2	1E2204X	POISE	
2	2	1	1E2013X	WEIGHT PLATE ASSY	
QTY.	QTY.	ITEM	PART NUMBER	DESCRIPTION	MATERIAL OR SOURCE
2E9200X-1	2E9200X	ASSY			

STATEMENT OF LIMITED WARRANTY

Detecto Scale warrants its equipment to be free from defects in material and workmanship as follows: Detecto warrants to the original purchaser only that it will repair or replace any part of equipment which is defective in material or workmanship for a period of one **(1) year** from date of shipment. Detecto shall be the sole judge of what constitutes a defect.

During the **first ninety (90) days** Detecto may choose to supply all necessary replacement parts and service during normal weekday working hours at no charge to the buyer.

After the first ninety (90) days Detecto will supply parts and service at the job site provided the owner agrees to pay the Dealer for all travel time, including mileage and test equipment, as well as any expenses incurred over the direct labor of the technician at the job site. This limited warranty honors only labor performed by Detecto authorized dealers.

This warranty does not apply to peripheral equipment not manufactured by Detecto; this equipment will be covered by certain manufacturer's warranty only.

This warranty does not include replacement of expendable or consumable parts. This does not apply to any item which has deteriorated or damaged due to wear, accident, misuse, abuse, improper line voltage, overloading, theft, lightning, fire, water or acts of God, or due to extended storage or exposure while in purchaser's possession. This warranty does not apply to maintenance service. Purchased parts will have a ninety (90) day repair or replacement warranty only.

Detecto may require components be returned to the factory; they must be properly packed and shipping charges prepaid. A return authorization number must be obtained for all returns and marked on the outside of all returned packages. Detecto accepts no responsibility for loss or damage in transit.

STATEMENT OF LIMITED WARRANTY

Conditions Which Void Limited Warranty

This warranty shall not apply to equipment which:

- A.) Has been tampered with, defaced, mishandled or have had repairs and modifications not authorized by Detecto.
- B.) Has had serial number altered, defaced, or removed.
- C.) Has not been grounded according to Detecto's recommended procedure.

Freight Carrier Damage

Claims for equipment damaged in transit must be referred to the freight carrier in accordance with freight carrier regulations.

This warranty sets forth the extent of our liability for breach of any warranty or deficiency in connection with the sale or use of the product. Detecto will not be liable for consequential damages of any nature, including but not limited to, loss of profit, delays or expenses, whether based on tort or contract. Detecto reserves the right to incorporate improvements in material and design without notice and is not obligated to incorporate improvements in equipment previously manufactured.

The foregoing is in lieu of all other warranties, express or implied including any warranty that extends beyond the description of the product including any warranty of merchantability or fitness for a particular purpose. This warranty covers only those Detecto products installed in the forty-eight (48) contiguous continental United States.



Ph. (800) 641-2008
E-mail: detecto@cardet.com
203 E. Daugherty
Webb City, MO 64870

02/06
Printed in USA
D268 WARRANTY DET

