

## Viral Kill for Indoor Dining 60" Credenza

### Features and Benefits

- Utilizes a combination of self-contained ultraviolet light and room temperature oxidation to destroy viruses and Volatile Organic Compounds (VOCs)
- Technology recommended by Center for Disease Control and Prevention, FDA and scores of scientists as effective against airborne coronavirus transmission
- Safe for use in occupied spaces 24 hours/day
- Destroys up to 99.9995% of airborne infectious aerosols in indoor spaces, so diners can come back inside
- Treats up to 9,000 cubic feet of air per unit; number of units and locations of each are customized for each restaurant
- Easy to clean – no contaminated filters
- Designed to blend into the decor of your space (available in ten finishes and four countertop options)
- Bulb life up to 8,800 hours
- IoT compatible with OpenKitchen (ConnectWare required)
- One-year limited warranty

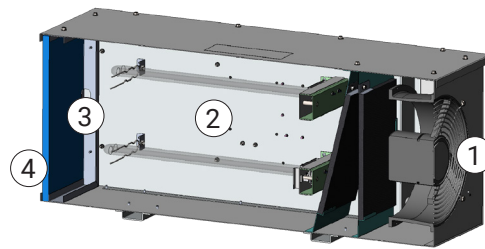

1. Contaminated air inlet
2. Airborne infectious aerosols and VOCs are eliminated
3. Oxidation catalyst
4. Clean air outlet



Reduction of MS2  
Bluezone by Middleby 450

Bioaerosol Type	Species	Trial ID		15 min.	30 min.	45 min.	60 min.
Virus	MS2 bacteriophage (RNA E. coli phage)	T1	Net Log Reduction	-1.52	-3.25	-4.25	-5.52
			Net % Reduction	96.9552%	99.9439%	99.9944%	99.9997%
		T2	Net Log Reduction	-1.48	-3.59	-5.05	-5.20
			Net % Reduction	96.7060%	99.9740%	99.9991%	99.9994%
		T3	Net Log Reduction	-1.75	-3.34	-4.50	-5.24
			Net % Reduction	98.2128%	99.9540%	99.9968%	99.9994%
<b>Average Net Log Reduction</b>				<b>-1.58</b>	<b>-3.39</b>	<b>-4.6</b>	<b>-5.32</b>
<b>Average Net % Reduction</b>				<b>97.291%</b>	<b>99.957%</b>	<b>99.9968%</b>	<b>99.9995%</b>

This study was conducted in compliance with FDA Good Laboratory Practices (GLP) as defined in 21 CFR, Part 58 using aerosolized MS-2 bacteriophage, a surrogate for SARS-COV-2, in a room-sized test chamber.

# 450

## Viral Kill for Indoor Dining 60" Credenza

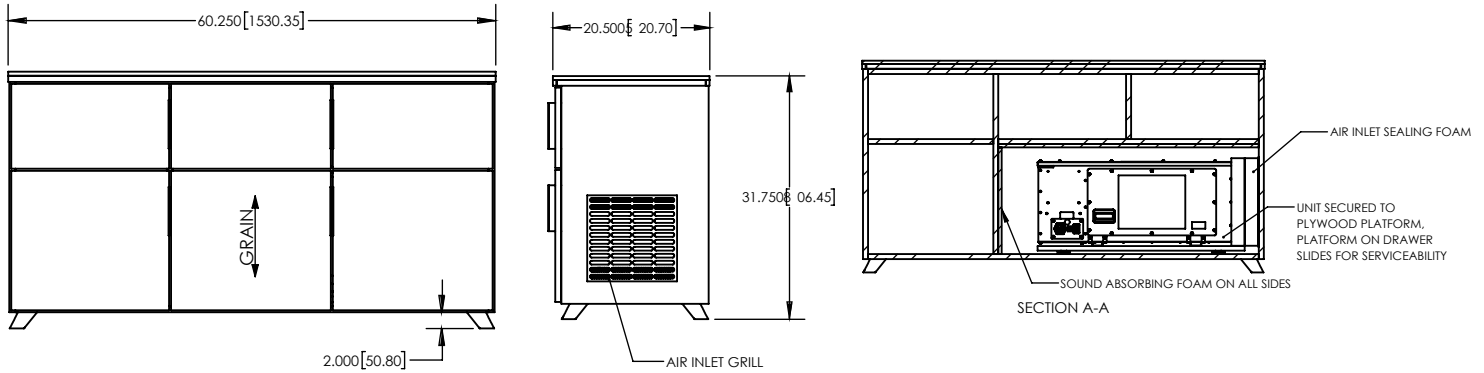

### TOWER ONLY SPECIFICATIONS

Dimensions	60.25" X 20.5" X 31.75" (1530 mm X 521 mm x 806 mm)
Weight	237 lb. (108 kg.)
Shipping Dimensions/Weight LTL Freight Class 250	66" x 24" x 38" (1676 mm x 610 mm x 965 mm) / 312 lb. (142 kg.)

### BLUEZONE UNIT ONLY SPECIFICATIONS

Dimensions	31" X 14" X 13.375" (787 mm X 356 mm x 340 mm)
Weight	26 lb. (12 kg.)
Shipping Dimensions/Weight	36" x 20" x 20" (914 mm x 508 mm x 508 mm) / 28 lb. (13 kg.)
Input Voltage and Current	120 VAC, 1-phase, 3 amps or 240 VAC, 1-phase, 1.5 amps
Electrical Connection	IEC 320-C13
Operating Environment	34°F-104°F (1°C- 40°C)
Flow Rate	150 CFM
Power	Max 350 watts
Certifications	cETLus Listed, ETL Sanitation, NSF/ANSI 2 Sanitation (Pending), California Air Resource Board (CARB) for no ozone emission