

22" X 28" PIPE SYSTEM FLOOR STANDING SIGN HOLDER

Item # PSSH28

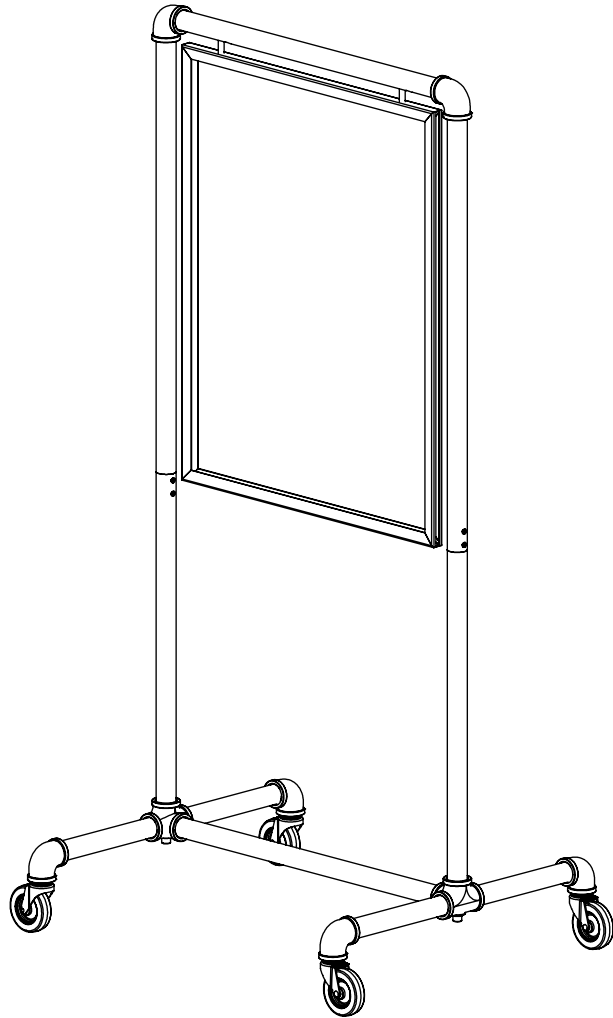

INCLUDED HARDWARE



2X
3/8-16 X 2.5" LONG
SOCKET CAP SCREW

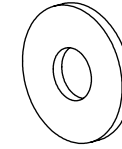

6X
3/8-16
FLAT WASHER



6X
3/8-16 SPRING
LOCK WASHER



8X
1/4-20 X 27mm LONG
SET SCREW

TOOLS REQUIRED

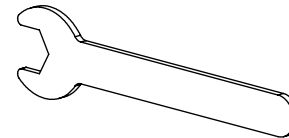

CASTER WRENCH



SMALL ALLEN KEY



LARGE ALLEN KEY

1

INSTALL CASTERS INTO BASE WITH FLAT WASHERS AND SPRING WASHERS AS SHOWN. TIGHTEN CASTERS WITH CASTER WRENCH

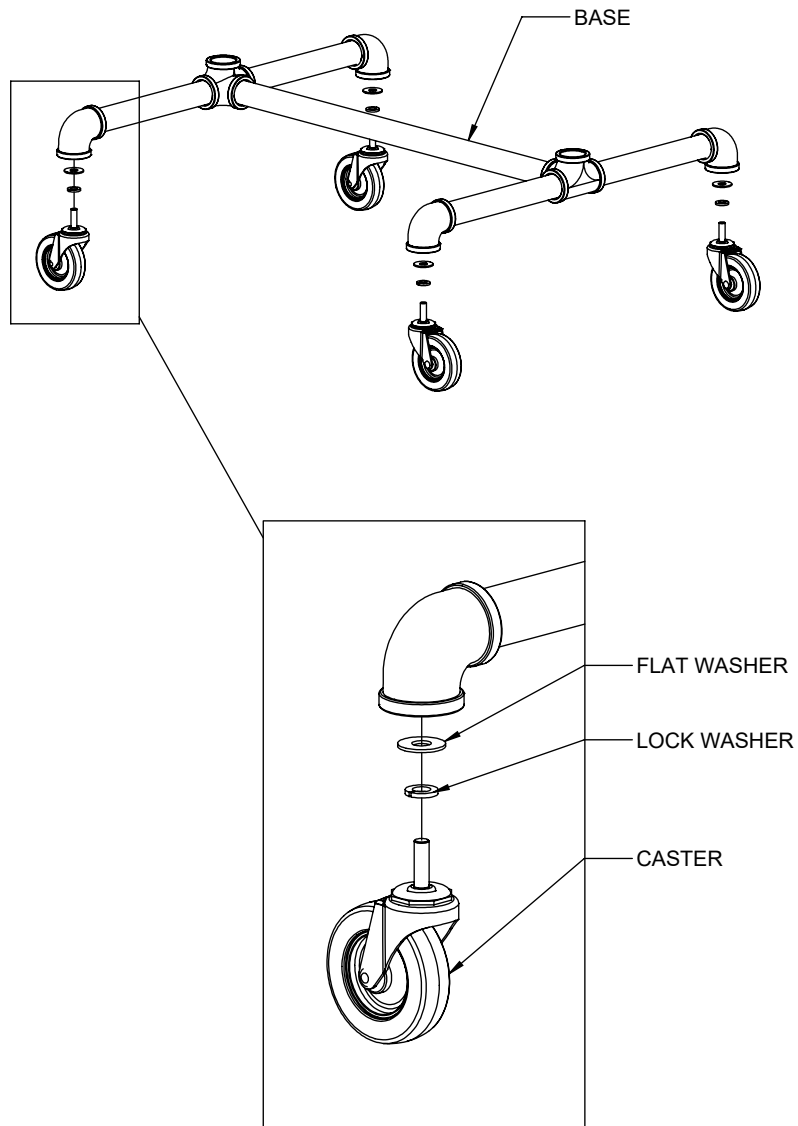

2

INSTALL UPRIGHTS INTO HANG BAR AND SECURE WITH SET SCREWS AS SHOWN. TIGHTEN WITH SMALL ALLEN KEY.

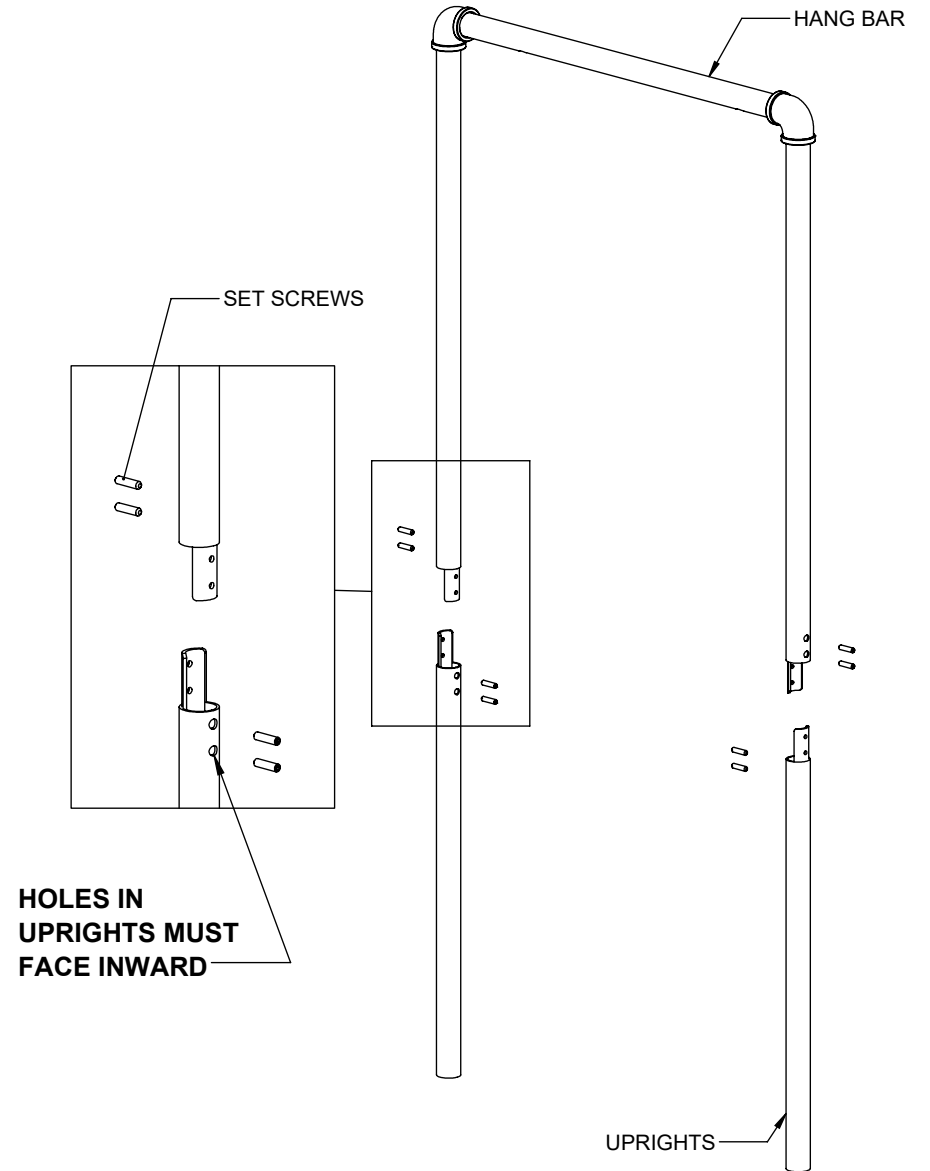

3

INSTALL THE ASSEMBLY FROM THE PREVIOUS STEP ONTO THE BASE AS SHOWN WITH CAP SCREWS FLAT WASHERS AND SPRING WASHERS. USE THE LARGE ALLEN KEY TO TIGHTEN CAP SCREWS.

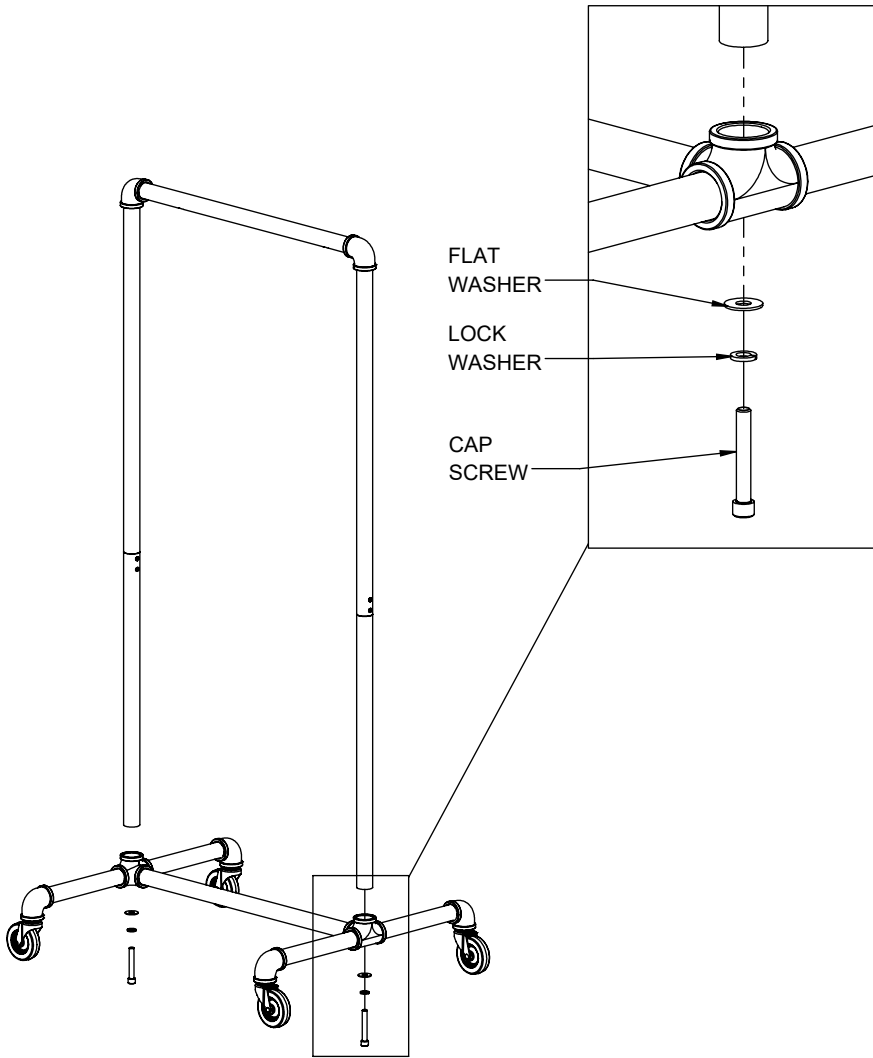

4

INSTALL THE SIGN HOLDER INTO THE HANG BAR AS SHOWN.

