

# TV MOUNT FOR PIPE SYSTEM FOR 50" DISPLAY MAXIMUM

ITEM # PSFSTV-F

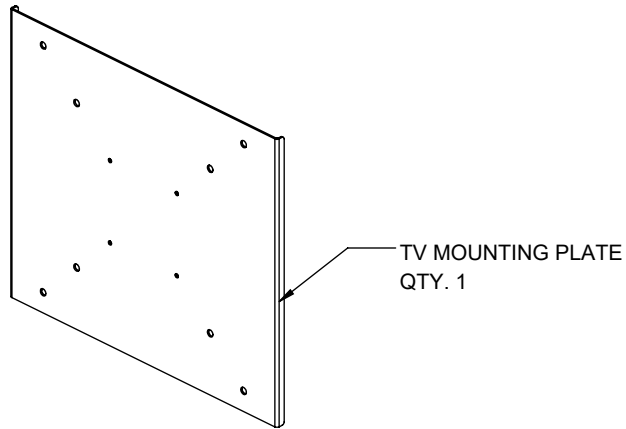

## INCLUDED HARDWARE (FOR HANG BAR ASSEMBLY)

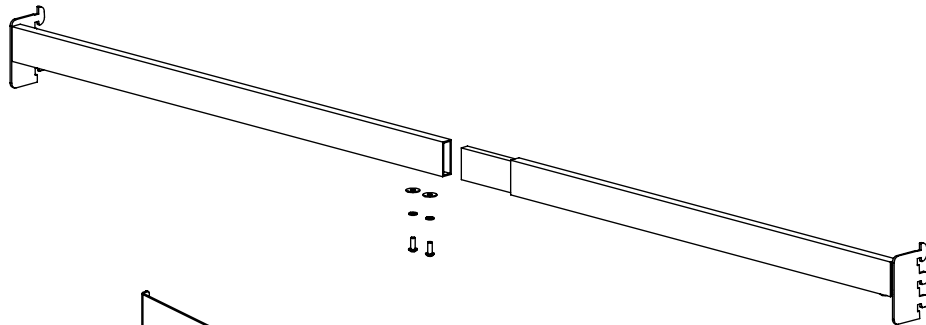
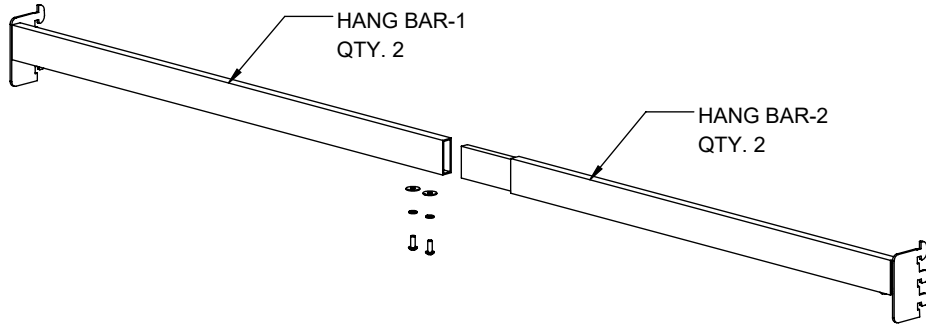
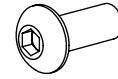

**4X**  
SOCKET HEAD SCREW



**4X**  
LOCK WASHER

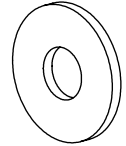

**4X**  
WASHER

## TOOLS REQUIRED



**ALLEN KEY**

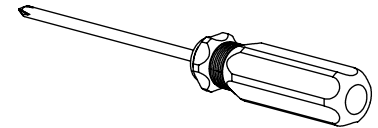

**PHILLIPS HEAD SCREW  
DRIVER  
(NOT INCLUDED)**

# DETERMINE WHICH ASSEMBLY YOU REQUIRE

NOTE: MAX DISPLAY SIZE IS 50"

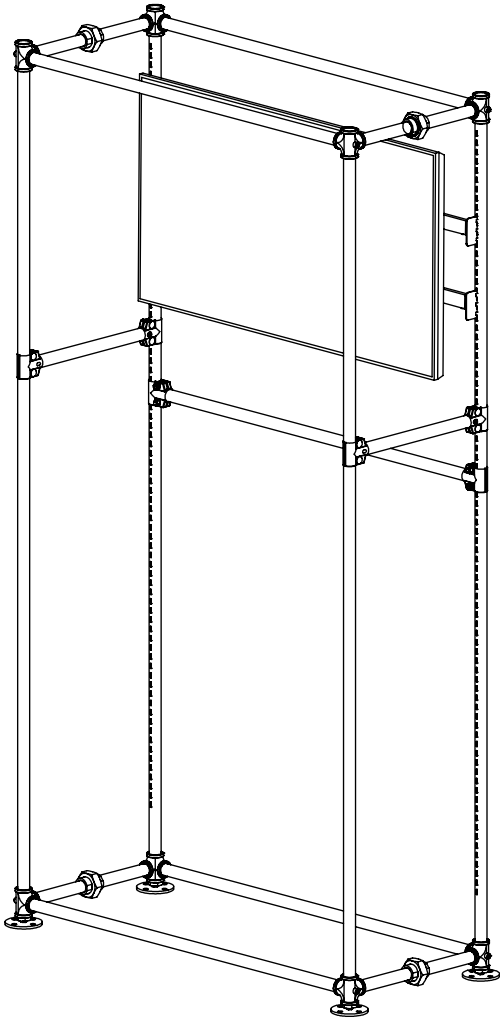

REAR MOUNT ON ON PSFS96

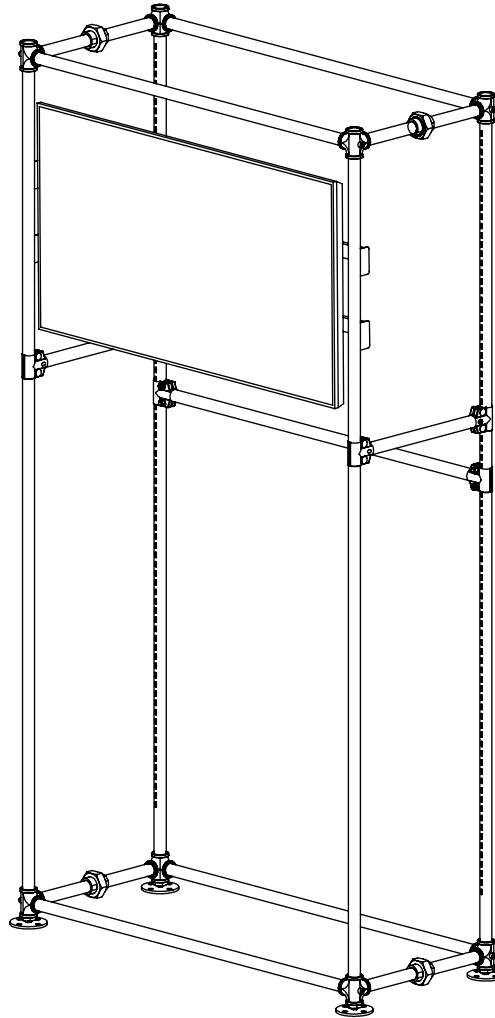

FRONT MOUNT ON ON PSFS96

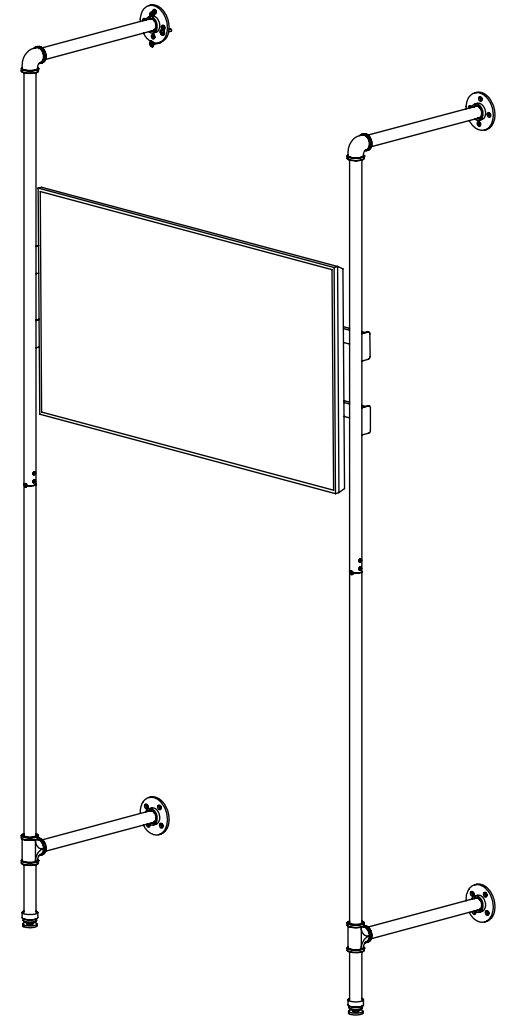

MOUNT ON PSOR

# HANG BAR ASSEMBLY

**1**

INSERT HANG BAR-2 INTO HANG BAR-1

SECURE WITH HARDWARE AS SHOWN

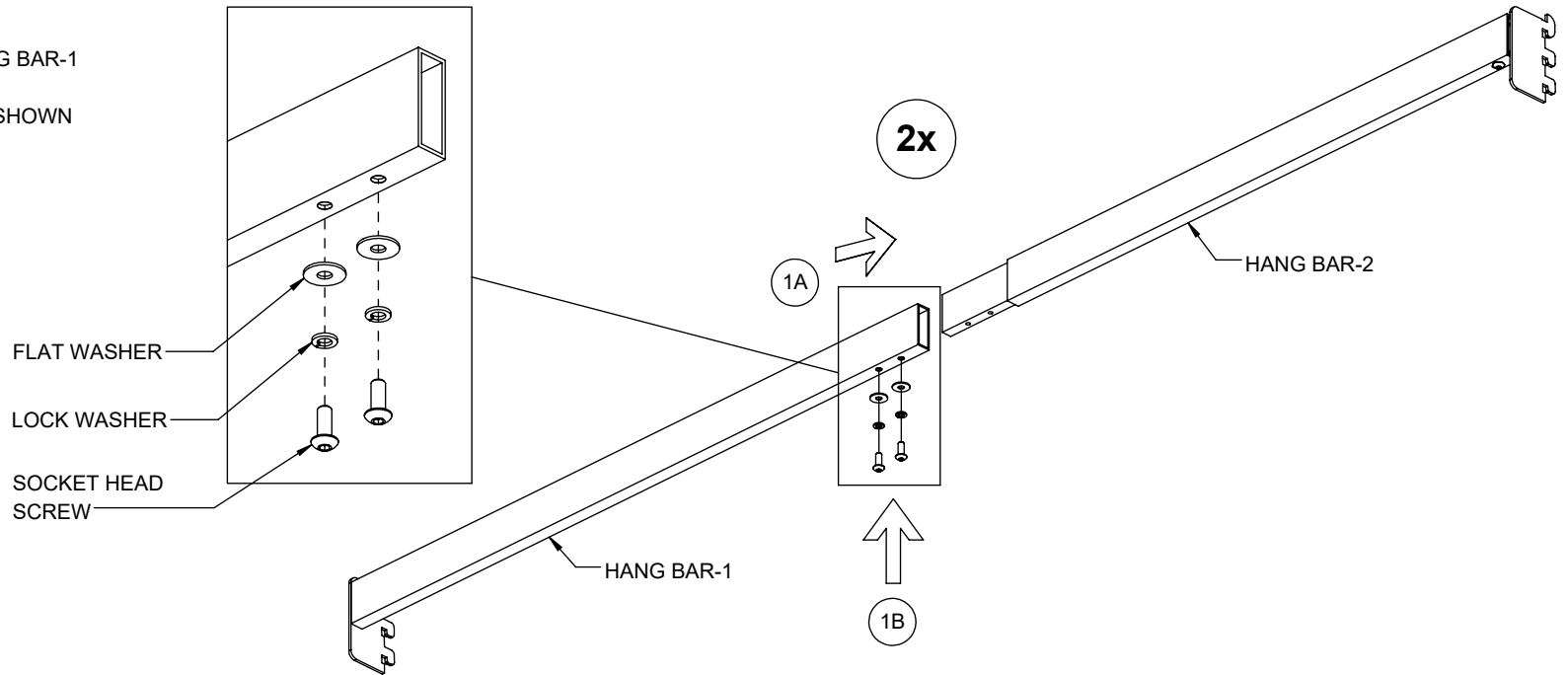

**2**

HANG BAR ASSEMBLIES ONTO PIPE FIXTURE 9 SLOTS APART.

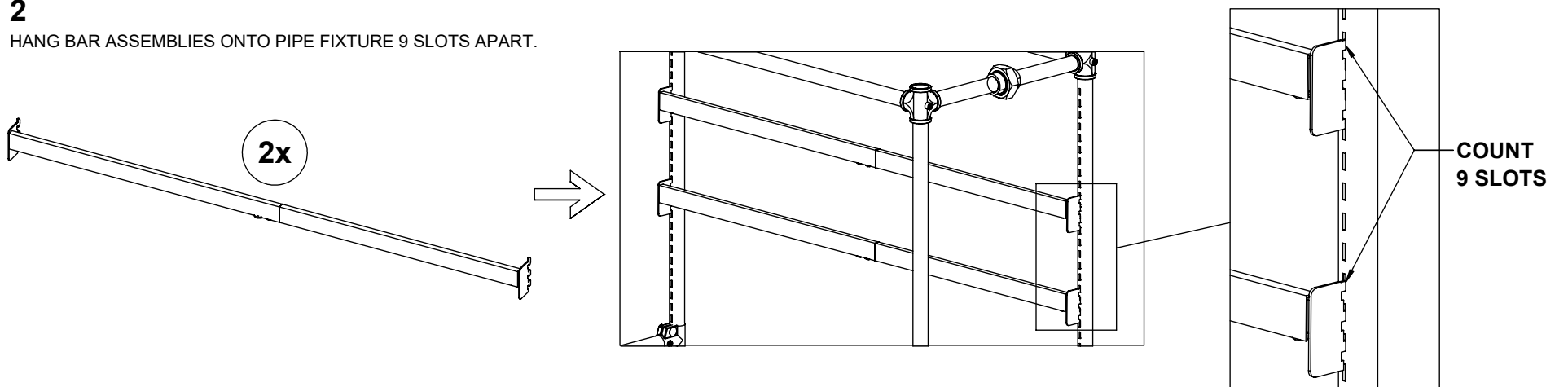

# DETERMINE HARDWARE TO SECURE MOUNTING PLATE TO T.V.

1

IDENTIFY THE TYPE OF TV BACKING.

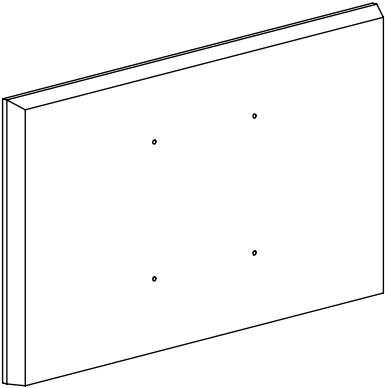
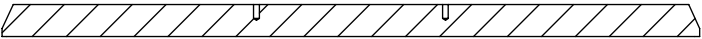

**FLAT BACK**

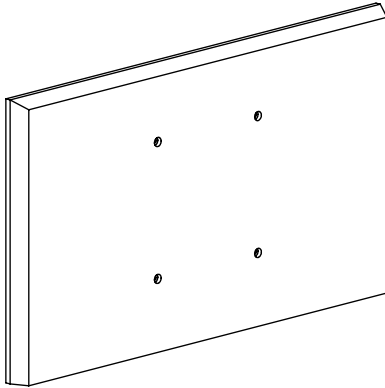
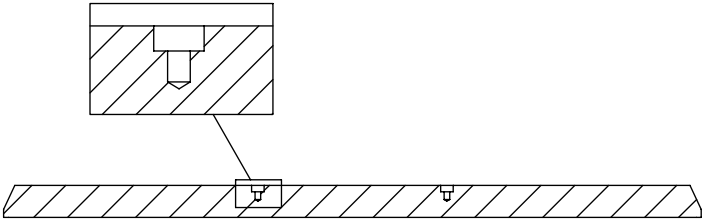

**INSET HOLES**

**NOTE:  
TV MOUNTING  
PLATE FITS VESA  
PATTERN SIZES:  
100 X 100  
200 X 200  
300 X 300**

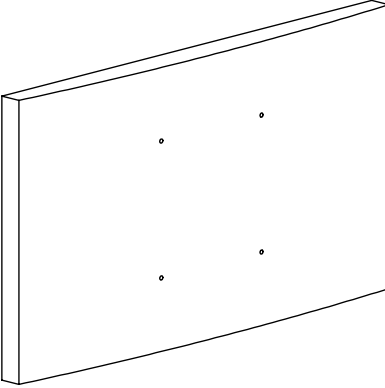

**CURVED BACK**

# DETERMINE HARDWARE TO SECURE MOUNTING PLATE TO T.V.

## 2

TEST HARDWARE SIZES AND LENGTHS FROM WHAT IS INCLUDED IN THIS KIT.

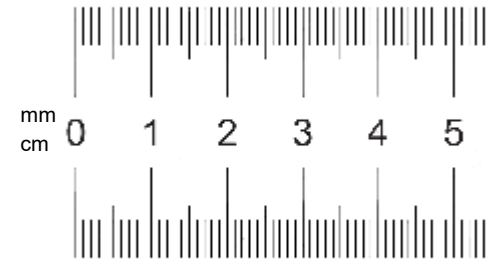

TV MOUNT HARDWARE	VESA PATTERN	QTY.
M4 X 12mm SCREW	100 x 100	4
M4 X 35mm SCREW	100 x 100	4
M5 x 12mm SCREW	200 x 200	4
M5 x 35mm SCREW	200 x 200	4
M4/M5 WASHER	100 x 100	4
M6 X 12MM SCREW	200 x 200	4
M6 x 35mm SCREW	200 x 200	4
M8 x 16mm SCREW	300 x 300	4
M8 x 20mm SCREW	300 x 300	4
M8 X 35mm SCREW	300 x 300	4
M6/8 WASHER	200 x 200/ 300 X 300	4
PLASTIC SPACER		4

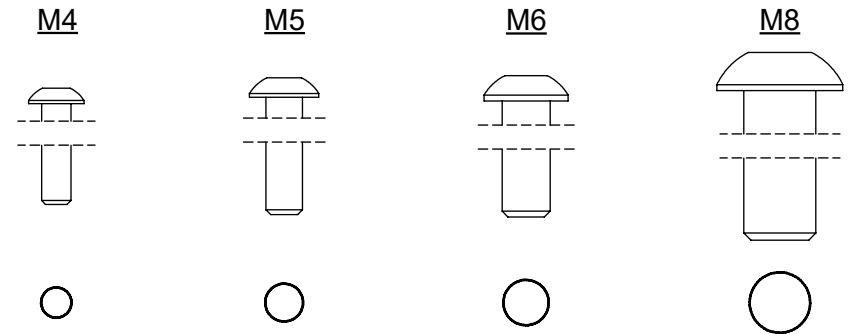

M4/M5 WASHER

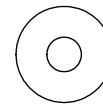

M6/M8 WASHER

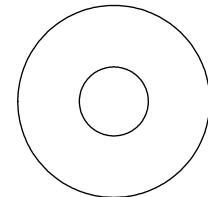

PLASTIC SPACER

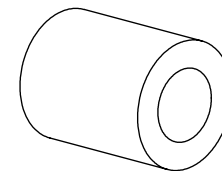

# DETERMINE HARDWARE TO SECURE MOUNTING PLATE TO T.V.

## 3

DETERMINE IF SPACERS ARE NEEDED

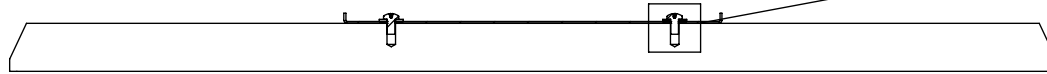

FLAT BACK TV: GO TO STEP 3A

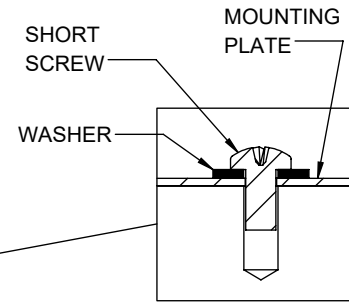

INSET HOLES: GO TO STEP 3B

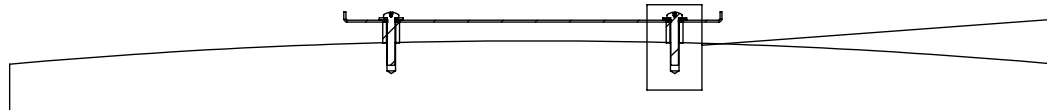
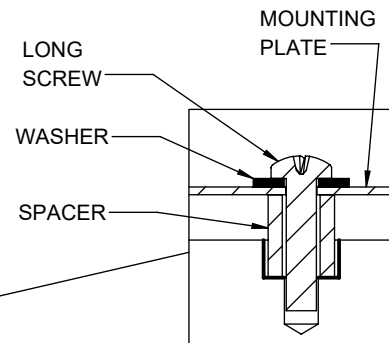

CURVED TV: GO TO STEP 3B

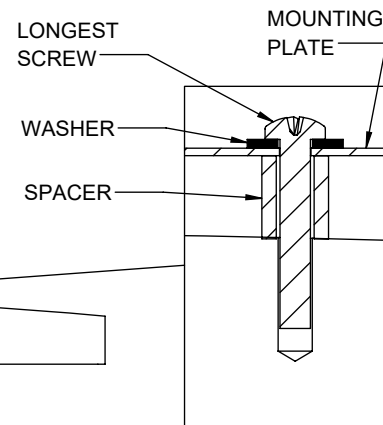

SELECT CORRECT SCREW SIZE FROM TV MOUNTING HARDWARE BAG. SELECT THE LONGEST SCREW LENGTH THAT WILL FIT AND TIGHTEN TV BRACKETS AGAINST TV.

IF SCREWS ARE TOO SHORT THEY WILL NOT THREAD INTO THE HOLES ON THE TV.

IF SCREWS ARE TOO LONG, TV BRACKETS WILL NOT TIGHTEN AGAINST TV.

IT IS POSSIBLE THAT NO COMBINATIONS OF THE PROVIDED HARDWARE WORK FOR YOUR TV BRAND.

IF THIS IS THE CASE, PLEASE CONTACT THE MANUFACTURER OF THIS MOUNTING KIT FOR ASSISTANCE.

# SECURE MOUNTING PLATE TO T.V.

**1**

FOR TV's THAT DO NOT REQUIRE SPACERS

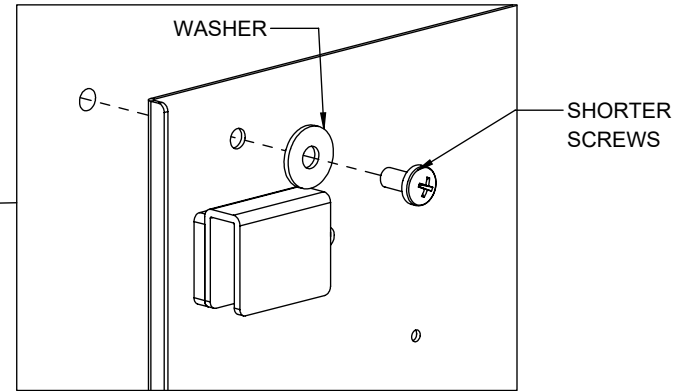
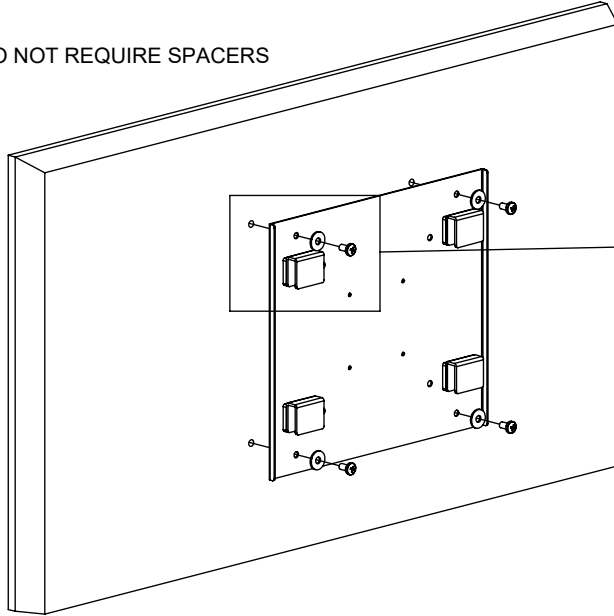

**2**

FOR TV's THAT REQUIRE SPACERS

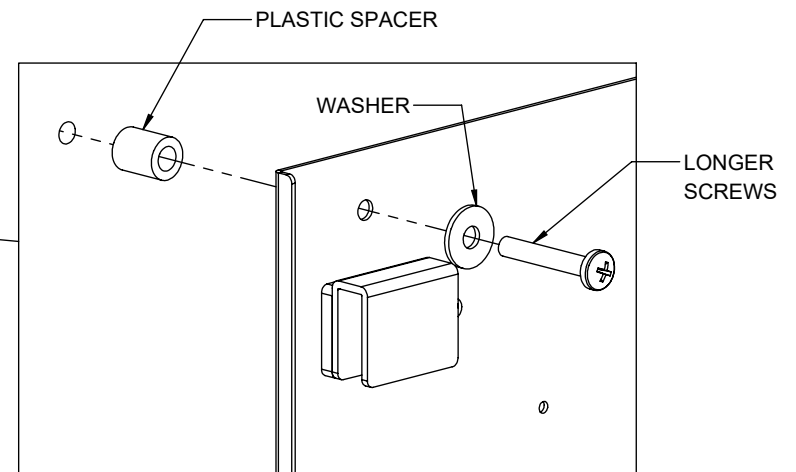
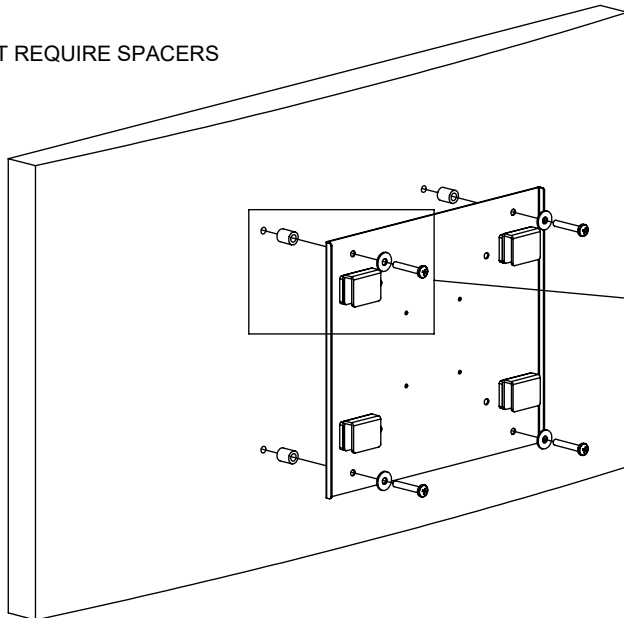

# HANG T.V. ON HANG BARS

