

frieling

OWNER'S MANUAL

Model No. 0501 and 0601

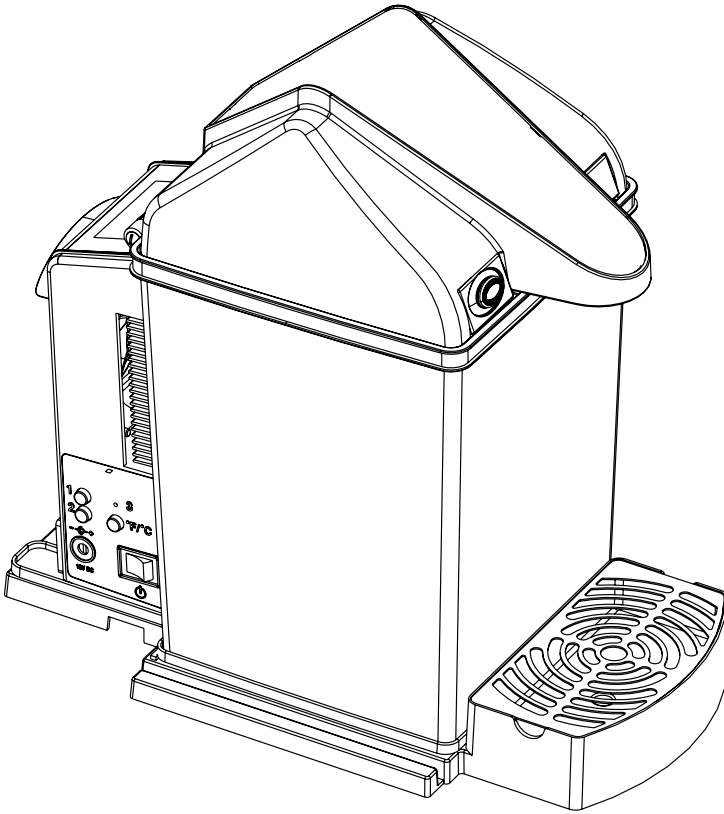

MILKchillerTM
by frieling

Important Safeguards

When using an electrical appliance, basic safety precautions should always be followed to reduce the risk of fire, electrical shock and injury to persons, including the following:

1. Read all instructions before using appliance.
2. Close supervision is necessary when any appliance is used near children.
3. This appliance is not for use by children.
4. The cord to this appliance should be plugged into a 120V AC electrical outlet only.
5. Do not operate any appliance with a damaged cord or plug or after the appliance malfunctions, or has been dropped or damaged in any manner. Contact Consumer Service for return authorization, examination, repair or adjustment.
6. If this appliance malfunctions during use, immediately unplug the cord from the outlet. Do not attempt to repair the malfunctioning appliance.
7. Unplug unit when not in use and before cleaning.
8. Do not let the power supply hang over edge of table or counter.
9. Use caution when transporting MILKchiller™.
10. Do not place on or near a hot gas or electric burner, or in a heated oven.
11. The use of accessory attachments is not recommended by the manufacturer as it may cause injuries.
12. Use MILKchiller™ unit only with the provided base and on a flat surface.

SAVE THESE INSTRUCTIONS

Important Safeguards (cont.)

CAUTION: Do not block the cooling fan in the back of the unit nor the exhaust ports on the side the MILKchiller™. Allow ample space for air circulation.

CAUTION: Do not immerse the power-supply, cord, or appliance in water or any other liquid.

CAUTION: Do not use metal scouring pads to clean the appliance. Pieces of the pad may break off and touch electrical parts.

CAUTION: Do not pour water or any liquid into the chilling chamber of the MILKchiller™.

CAUTION: The room temperature for normal operation of the MILKchiller™ is below 30°C, 86°F. We cannot guarantee proper functioning of the MILKchiller™ in a room or environment above these temperatures.

Polarized Plug

This appliance has a polarized plug (one blade is wider than the other). As a safety feature to reduce the risk of electrical shock, this plug is intended to fit in a polarized outlet only one way. If the plug does not fit fully in the outlet, reverse the plug. If it still does not fit, contact a qualified electrician. Do not attempt to modify the plug in any way.

Power Cord Instructions

A long power cord is provided so that the MILKchiller™ can be located away from the power outlet. Care must be taken to ensure the cord does not become entangled or located where tripping can occur.

MILKchiller™

Parts and Accessories

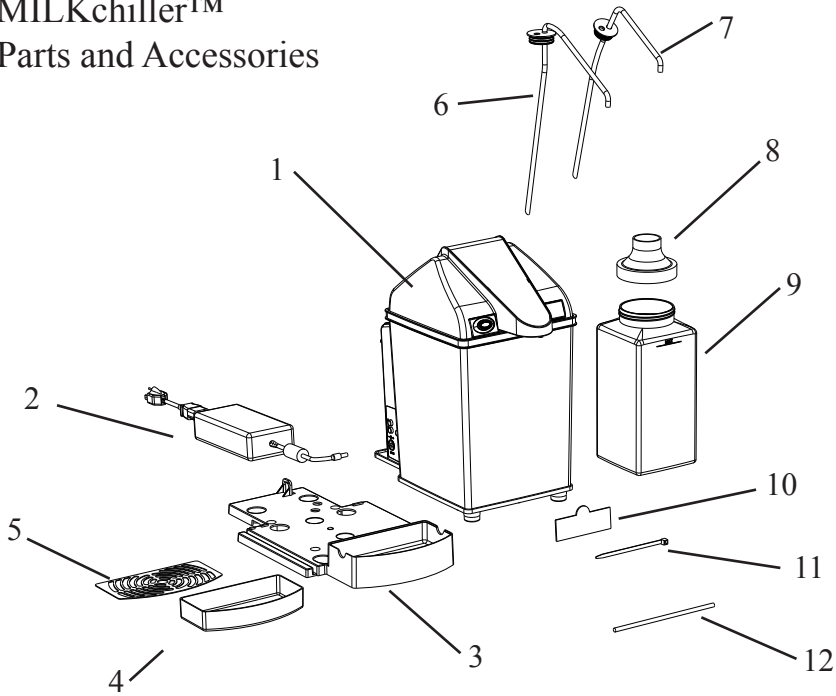

Parts List		Item No.
1.	MILKchiller™ unit	0501 or 0601
2.	Power Supply and Plug	0713
3.	Base with Drip Tray Cup	0721
4.	Drip Tray Insert	0710
5.	Drip Tray Metal platform	0711
6.	Disposable Straw for Plastic Cartons and MILKchiller™ Refillable Container	0702
7.	Disposable Straw for Paper Cartons	0701
8.	MILKchiller™ Refillable Container Lid (available separately, not included)	0723
9.	MILKchiller™ Refillable Container (available separately, not included)	0724
10.	Air Filter	0705
11.	Wire tie	0725
12.	Pipette	

Please see pages 20 - 23 for complete parts/accessory order details.

Congratulations!

MILKchiller™ is the unique solution for your beverage station because it...

- Maintains dairy products at a safe temperature of 41°F or below.
- Features an LCD displays 8 types of dairy products: whole; cream; ½ & ½; 1%; 2%; skim; fat-free; and soy; in 5 different languages: English, French, German, Italian and Spanish.
- Accommodates standard ½ gallon dairy cartons or plastic containers.
- Will also accommodate the dishwasher safe, MILKchiller™ Refillable Container.
- Dispenses dairy products with a simple press of a button.
- Eliminates mess and waste.
- Is easy to operate and to replace the dairy container.

Before Using for the First Time

1. Carefully unpack the MILKchiller™ from the box.
2. Read all of the instructions included in this manual.
3. Remove all the packing material including the white wrappers protecting the stainless steel components.
4. Make sure the MILKchiller™ is unplugged and the power switch is in the OFF position.
5. Wipe exterior surfaces with a damp cloth. Dry thoroughly with a soft cloth. DO NOT use harsh or abrasive cleansers as these can damage the exterior surfaces.

CAUTION: Do not immerse the power supply, the cord, or the appliance in water or any other liquid.

6. If purchased, remove the MILKchiller™ Refillable Container and lid. Wash them in warm, soapy water or in the upper rack of the dishwasher.
7. Thoroughly dry the MILKchiller™ Refillable Container and lid.

The MILKchiller™ is now ready for use.

Plug the power supply connector into the Power Input on the MILKchiller™ control panel. Connect the power supply to the power cord and plug it into the wall outlet. Set the Power Switch to ON.

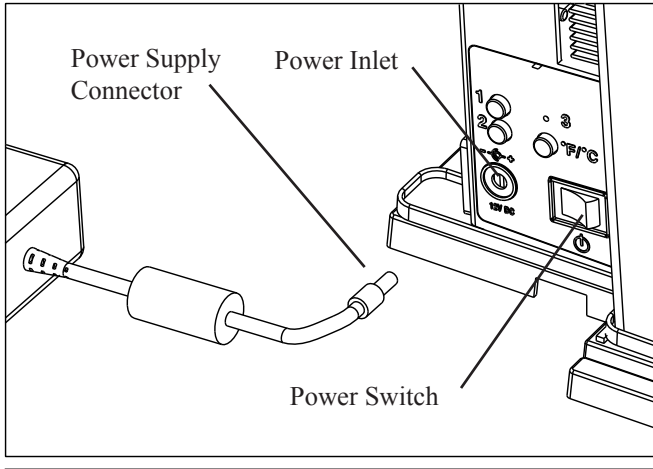

Upon start up, the LCD will alternately flash COOLING, LOW and WHOLE until the MILKchiller™ has reached the safety standard temperature. (The “LOW” message will disappear when the full carton or container is inserted into the chilling chamber.)

When it has reached the safety standard temperature, the LCD will display the default setting “WHOLE”.

For more information on the setting display, please see the section DISPLAY SETTINGS and CONTROL PANEL FUNCTIONS.

Fine Tuning the Low Level Indicator

The Low Level Indicator has been calibrated to trigger at approximately 18 ounces, 1/4 of a carton. This is the minimum amount of liquid remaining in the carton when the LOW indicator flashes. The Low Level Indication can be adjusted to trigger for more liquid remaining in the carton if desired.

1. Locate the calibration screw on the underside of the MilkChiller™ just behind the drip tray.

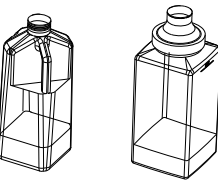
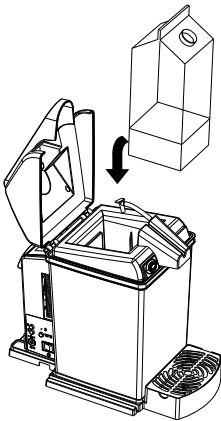
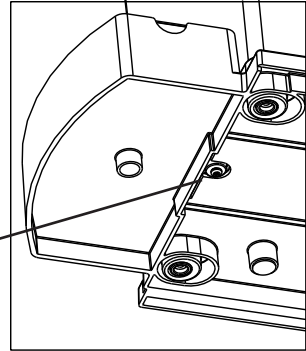

2. Fill a container 1/4 full or more with liquid. This is the approximate amount of dairy product remaining in the container when the LOW indicator flashes on the display.

Place container in the MilkChiller™ and close the lid.

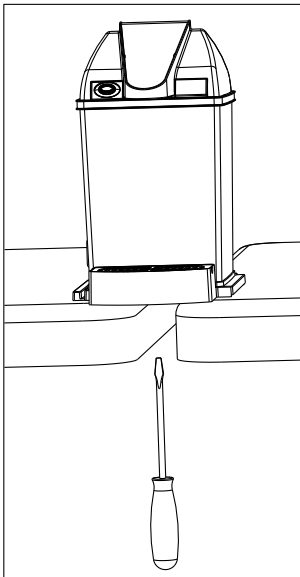

3. Place the MilkChiller™ on a flat surface that will provide access to the calibration screw. We suggest using an inside corner of a counter, or pushing two tables together leaving 2 inches between them for access to the screw.
4. Using a flathead screwdriver, SLOWLY adjust screw on the bottom in a clockwise manner just until the LOW indicator is flashing.
5. Further adjust the screw 1/2 turn to complete the calibration.

If, after time, the LOW indicator does not flash at the desired liquid level, readjust the calibration screw as outlined above.

The MILKchiller™ can now be loaded with a ½ gallon paper carton or the MILKchiller™ Refillable Container filled with dairy product.

It is required to refrigerate all dairy products prior to use in the MILKchiller™. If using shelf stable milk, the MILKchiller™ will not operate until the milk has cooled to the safe temperature specification.

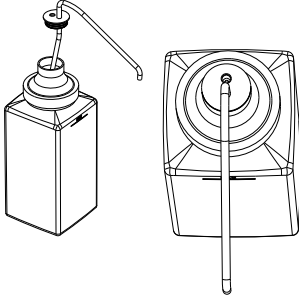

How To Insert Disposable Straw into MILKchiller™ Refillable Container:

1. Unscrew lid from container.
2. Fill container with dairy product up to the MAX Fill Line.
3. Screw on lid.
4. Insert Disposable Straw for Plastic into opening in lid orienting the holes front to back as shown.
5. Press straw cap into opening for a tight fit.

How To Insert Disposable Straw into Paper Half Gallon Container:

1. Unscrew the cap and remove the inner seal on the pour spout.
2. Insert the Disposable Straw for Paper into the pour spout.
3. Ensure the straw is pointing forward and orient the holes side by side as shown.
4. Press straw cap into opening for a tight fit.

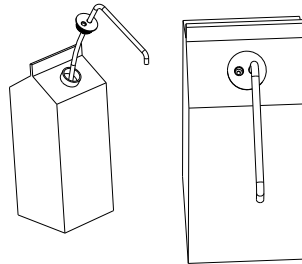

How To Insert Disposable Straw into Plastic Half Gallon Container:

1. Remove the cap on the pour spout.
2. **Pour out roughly 2 oz. of milk from plastic half gallon container.***
3. Insert the Disposable Straw for Plastic into the pour spout and orient the holes front to back as shown.
4. Press straw cap into opening for a tight fit.

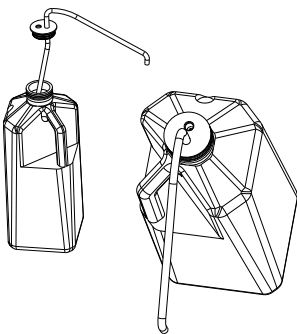

* Some dairy factories fill plastic containers to the top. This overfilling can cause some liquid to spill when the container is inserted into the chilling chamber. Therefore we recommend pouring out some liquid before inserting the straw.

If the Disposable Straw cap does not fit into the pour spout on the container, please use the MILKchiller™ Refillable Container.

Load Container into MILKchiller™

To load the container into the MILKchiller™, regardless of the type of container:

1. Lift the lid by pulling upward on the dispensing spout.
2. Orient the container so that the Disposable Straw is pointing to the front of the machine.
3. Reposition the Air Hose with Air Hose Fitting to clear the path for the container.
4. Insert the container into the chilling chamber until it sits on the bottom surface. Align the Disposable Straw to fit tightly in the forward channel.

PLEASE NOTE: If the liquid escapes from the straw while inserting the container, please lift the container out of the chamber, remove the straw and pour some liquid out. The container was overfilled.

5. Insert the Air Hose Fitting into the second hole in the Disposable Straw by looping around the straw counter clockwise. See drawings for orientation. Press down for a tight fit.
6. Lower the lid to close the machine.

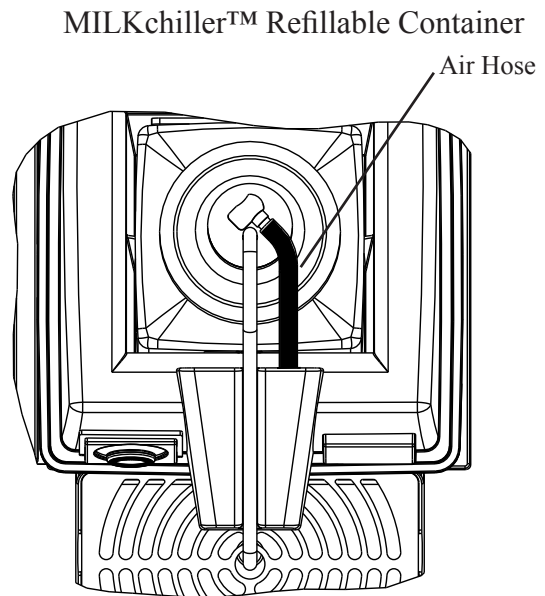
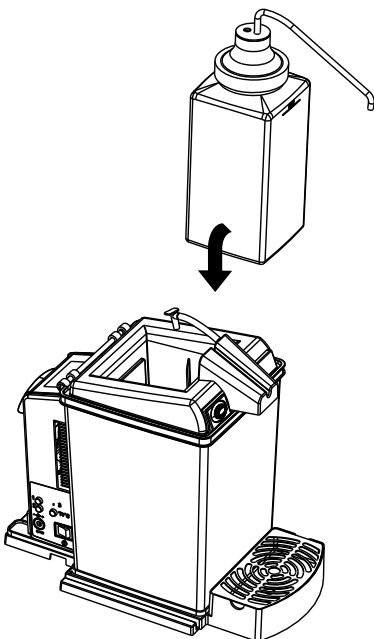

Paper Half Gallon container

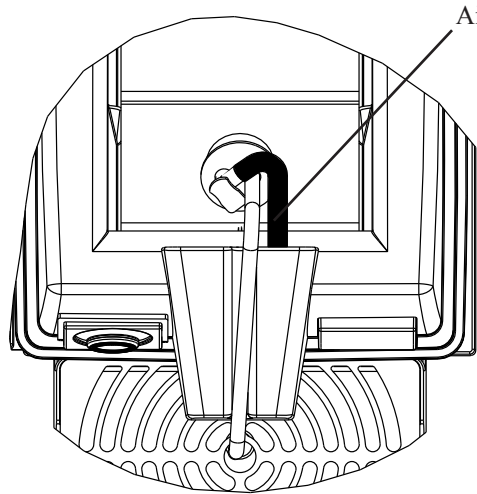
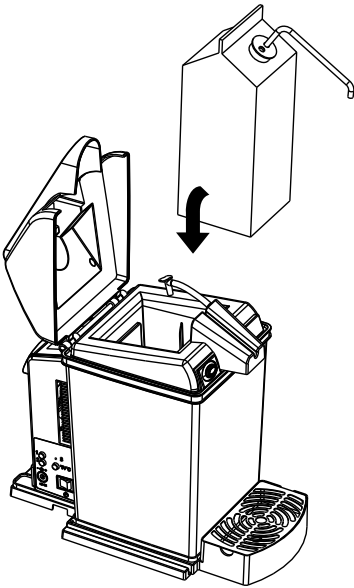

Air Hose

Plastic Half Gallon container

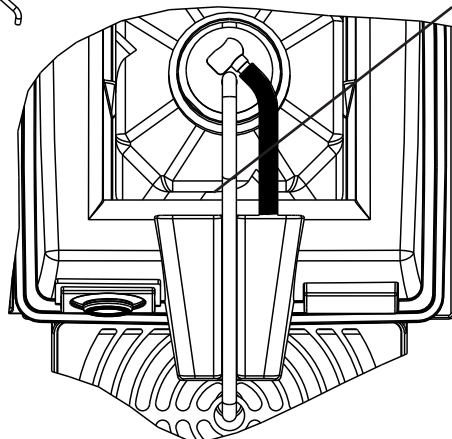
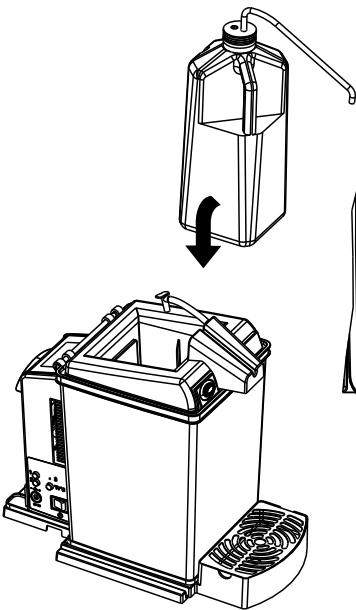

Air Hose

Please remember to pour out 2 oz. of liquid prior to loading plastic ½ gallon carton into MILKchiller™.

Control Panel Functions

The MILKchiller™ is programmed for use worldwide. The LCD displays the dairy contents in 5 different languages.

The MILKchiller™ must be initialized before use by first setting the language, and then setting contents.

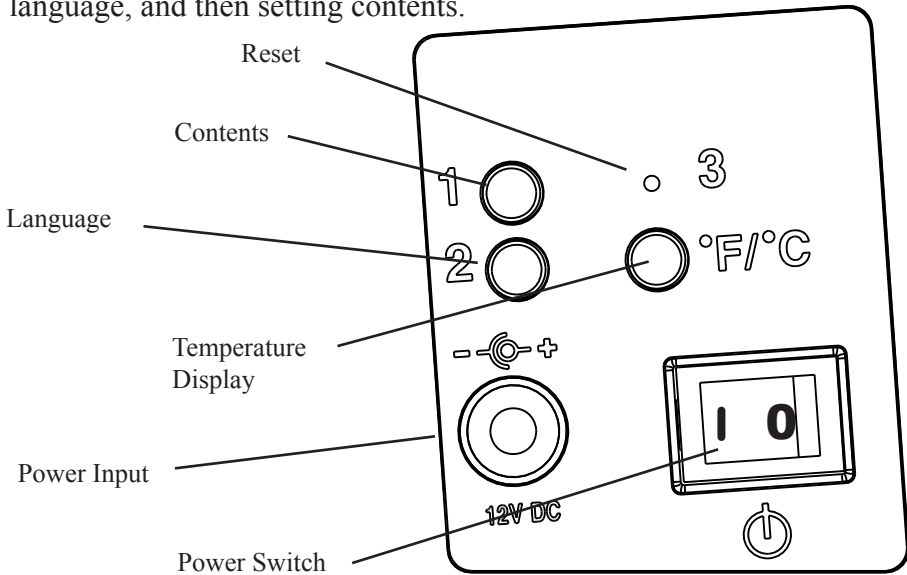

Language Button – Button 2

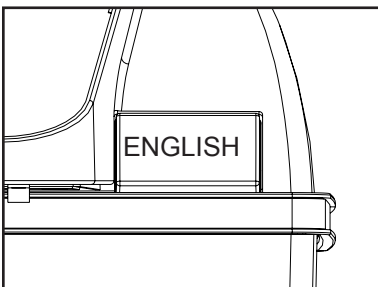

Sets the language in which the dairy contents are displayed. Pressing the button cycles through the 5 language options: ENGLISH, GERMAN, ITALIAN, FRENCH, SPANISH.

To set the LANGUAGE: Stop pressing the Language Button when the desired language is displayed. After a few seconds the default content of WHOLE (or the equivalent in another language) will be displayed.

Contents Button – Button 1

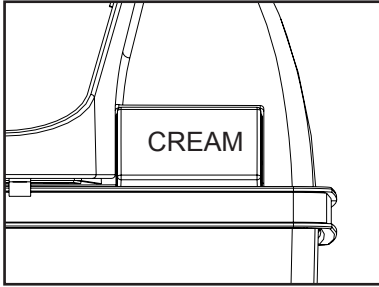

Sets the display to show the contents of the container in the MILKchiller™.

Pressing the button cycles through the 8 types of dairy product: WHOLE, ½ & ½, 1%, 2%, SKIM, FAT FREE, SOY, CREAM.

To set the CONTENTS: Stop pressing the Contents Button when the desired dairy type is displayed.

To Change the CONTENTS display: press the CONTENTS button to cycle through the dairy types, stopping on the desired type to display.

Reset Button – Button 3, internal button, for operator use only.

By pressing the internal button with a small sharp object such as a paper clip, the display is reset to the manufacturer's default settings. The default settings are ENGLISH and WHOLE. After resetting the MILKchiller™, the LANGUAGE button and CONTENTS button must be set to the desired display settings.

Temperature Display Button – for operator use only.

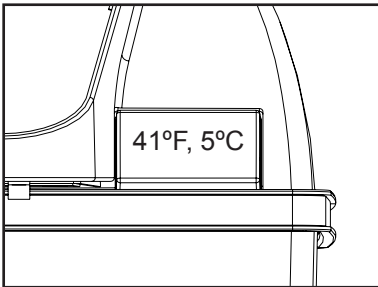

Pressing and holding the Temperature Display button shows the temperature of the dairy product on the LCD in °F and °C. This is for inspection purposes only. Releasing the button returns the display to the last setting.

Power Input – connector of the power supply, provided with each unit.

Power Switch – ON / OFF power switch. When the MILKchiller™ is powered off and on, the display retains its last setting.

Display Settings

The LCD on the front of the machine has many uses.

1. It shows the contents of the MILKchiller™ in daily use.
2. It displays the temperature of the liquid when Temperature Button is pressed.
3. It communicates the status of the machine:

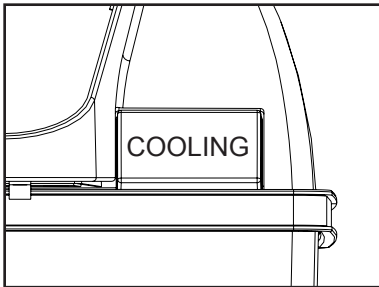

When the unit is first starting up the LCD flashes COOLING until it has reached cooling temperature.

If after 2 hours the MILKchiller™ does not reach cooling temperature, SERVICE is flashed on the LCD, and the pump will not operate.

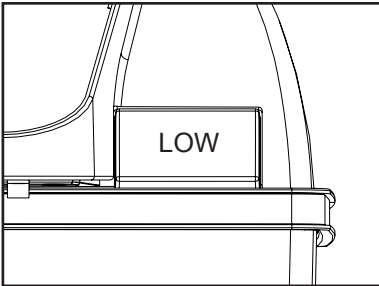

When the level of the liquid becomes low, the machine notifies the operator by flashing LOW.

The operator is alerted that the dairy product needs to be refilled soon.

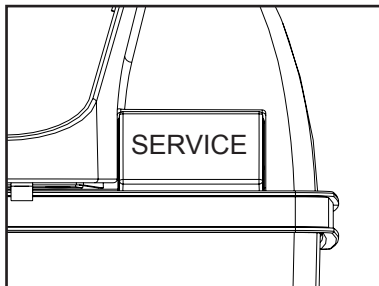

If SERVICE is flashing on the LCD, the MILKchiller™ should be returned for service.

This indicates the machine is not cooling to the safe temperature specification, and the dairy product may not be safe to ingest.

Dispensing Dairy Product

The push button on the left side of the MILKchiller™ causes the dairy product to be delivered through the dispensing spout. Dairy product will be delivered for as long as the button is depressed up to 60 seconds. There might be a slight delay between pushing the button and the delivery of the dairy product.

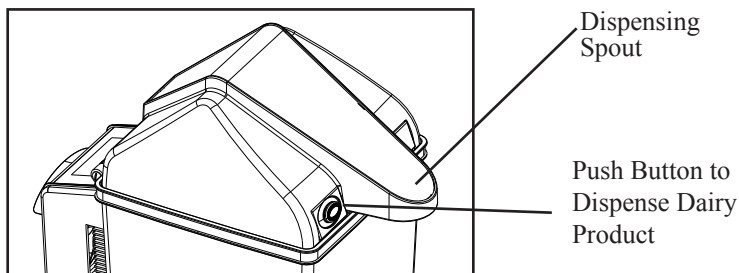

PLEASE NOTE: The force of depressing the Push Button may cause the LOW level indicator to flash. When the button is released, the LOW level indicator will disappear.

Removing Empty Carton or Container

The MILKchiller™ notifies the operator that the content of the container is getting low by flashing LOW on the display. To remove an empty carton or container:

1. Lift the lid by pulling upward on the dispensing spout.
2. Disengage the Air Hose Fitting and Air Hose from the Disposable Straw Cap.
3. Lift the empty container from the chilling chamber.
4. Dispose of empty container and Disposable Straw according to local recycling laws and policies.
5. Clean the Chilling Cavity as outlined in the Care and Cleaning Section.

To refill the MILKchiller™ with a full carton or container, follow the instructions found in section INSERT DISPOSABLE STRAW and LOAD CONTAINER.

Before Leaving for the Day

1. Remove the container from chilling chamber and place in refrigerator for overnight storage.
2. Turn OFF the MILKchiller™ to save energy.

Fasten Base to Countertop

The base is equipped with two keyholes for locking it to the countertop, if desired.

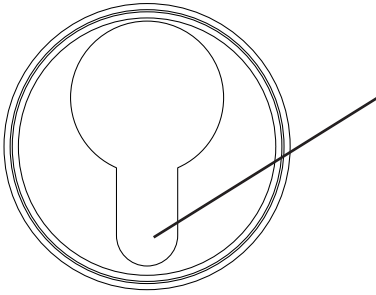

1. Place base at desired location on counter top.
2. Mark screw locations at the bottom of the keyhole.
3. Remove base. Drill pilot holes into countertop.
4. Replace base, and drill screws into countertop to lock down base.

To move location of base:

1. Back out screws part way to unlock base.
2. Move base forward to clear screw head.
3. Lift base off counter top.

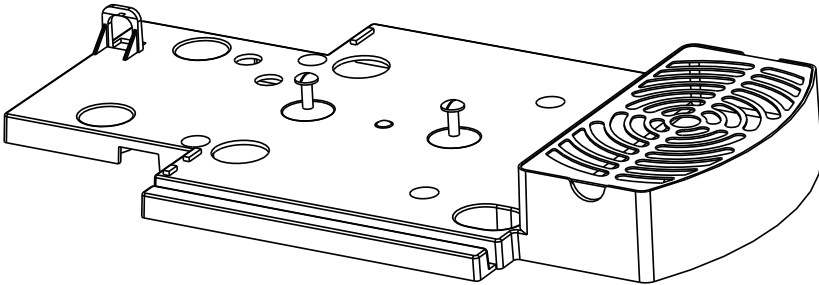

Lock MILKchiller™ to Base

Place the MILKchiller™ on the base, inserting the feet into the corresponding holes in the base.

At the back of the unit and base, there are locking tabs that can be used to secure the MILKchiller™ to the base. Insert the provided wire tie through both openings in the locking tabs and fasten. A small pad lock can be looped in the locking tabs for added security.

PLEASE NOTE: do not over tighten the wire tie, as some movement is required.

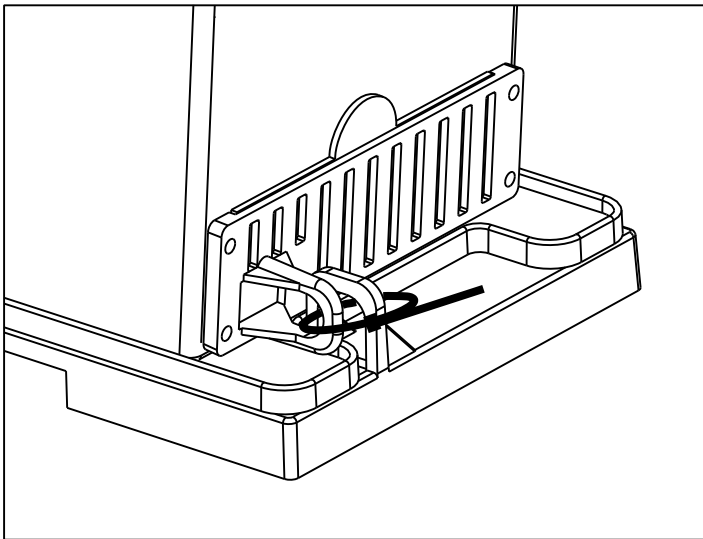

Drip Tray Features

The Drip Tray is an integral part of the base.

The Drip Tray insert is provided so that when the base is fastened to the countertop, the insert can be removed and emptied.

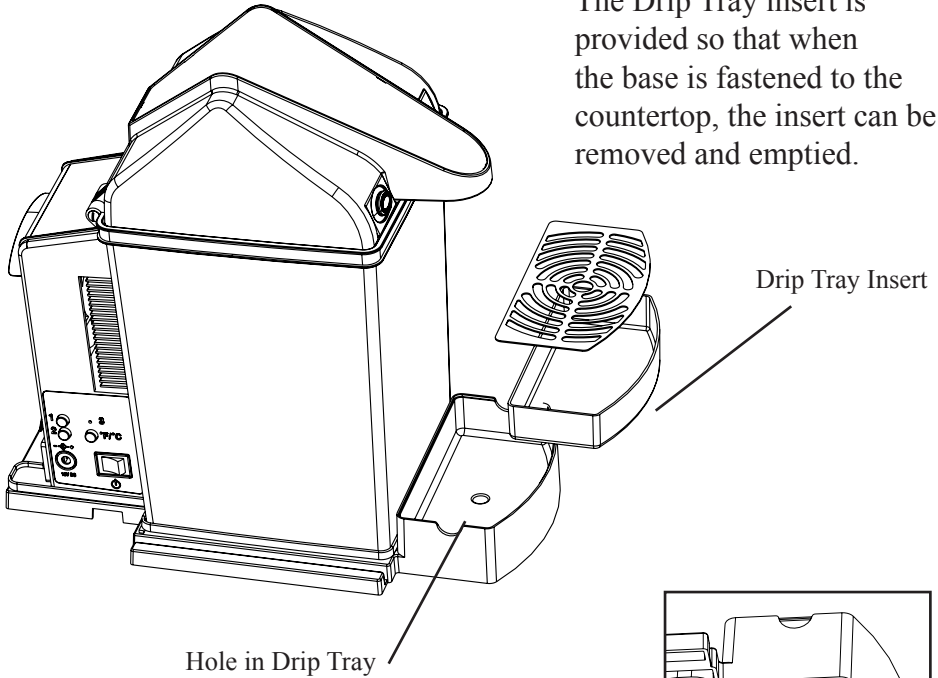

There is a fitting located on the underside of the Drip Tray to which a hose can be attached.

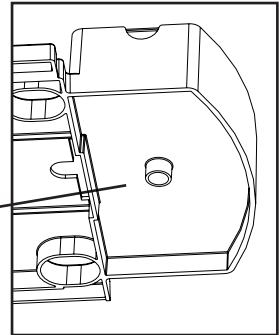

A Drain Hose can be routed beneath the counter to a bin to collect larger amounts of excess liquid.

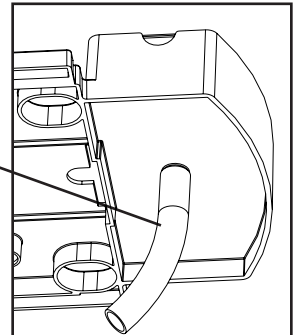

In this case, the Drip Tray Insert is removed and not used.

Replace the Air Filter

The Air Filter located at the lower back of the MILKchiller™ filters the air being used to dispense the dairy product. It is recommended to change the filter at least once every three months, more often if the environment requires and the Air Filter turns dark in color.

To Replace the Air Filter:

1. Gently pull upwards on the tab extending above the plastic grill.
2. Lift filter out of grill and dispose.
3. Load replacement filter by sliding it along the back wall and into the slot between the grill and the housing.
4. It may be necessary to loosen the 4 screws in the grill to free or load the filter. Be sure to tighten the screws after loading the Air Filter.

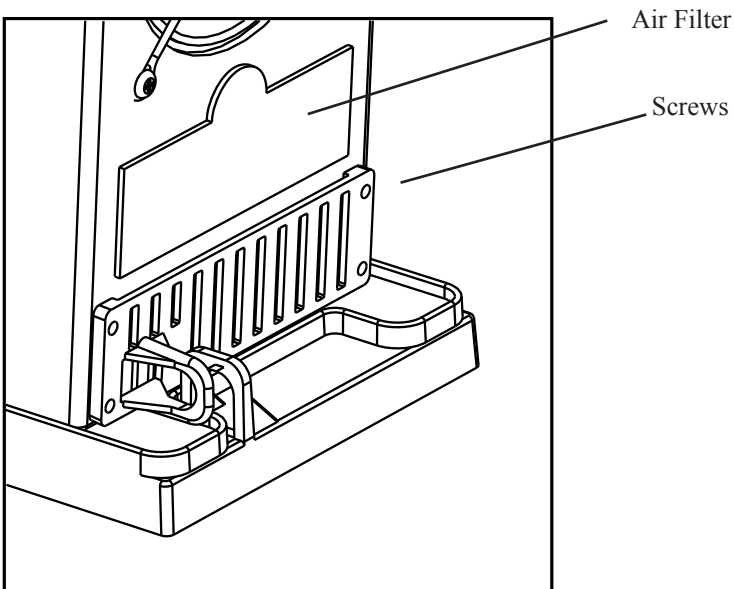

Care and Cleaning

CAUTION: Do not immerse the power supply, cord, or appliance in water or any other liquid.

CAUTION: Do not use metal scouring pads to clean the appliance. Pieces of the pad may break off and touch electrical parts.

CAUTION: Do not pour water or any liquid into the chilling chamber of the MILKchiller™.



1. Unplug the MILKchiller™, open the lid and allow all parts to reach room temperature before cleaning.
2. Clean the outside of the MILKchiller™ with a clean damp sponge. Do not use an abrasive cleaner, as it may damage the exterior finish.
3. Clean the inside of the MILKchiller™ with a clean sponge and a small amount of mild dish detergent. Wipe dry with a paper or cloth towel.
4. The MILKchiller™ Refillable Container and Lid can be washed with warm, soapy water or placed on the top shelf of the dishwasher. Dry thoroughly before next use.
5. The base and drip tray insert can be washed with warm, soapy water or placed in the dishwasher.
6. The Drip Tray Metal Platform can be washed with warm, soapy water or placed in the dishwasher.
7. If using the drip tray and hose, run hot soapy water through the drip tray and hose into the large bin to clean.
8. Do not clean the Disposable Straws. They are designed to be thrown away with each carton, and re-use may risk contamination.
9. The pipette is provided to clean the Disposable Straws in an emergency situation where there are no clean Disposable Straws. Starting with a new straw each time the dairy product is replaced eliminates contamination risks. The exchange is easy, fast, safe, and compliant with health department regulations. Please recycle used straws.
10. Let all parts dry thoroughly prior to plugging in the MILKchiller™ and using.
11. Regularly clean fan and fan grill with a damp cloth to remove dust.





Troubleshooting

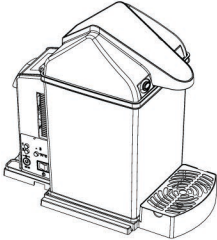
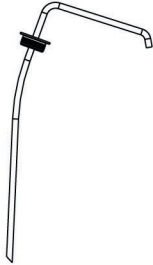
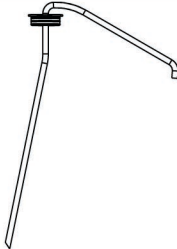
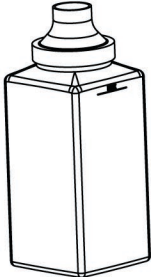

<p>The MILKchiller™ is plugged in, however, the display is blank.</p>	<p>Make sure the cord is securely plugged into the power supply and the Power Switch is in the ON position.</p>
<p>The MILKchiller™ is plugged in and the Switch is in the ON position and the display is blank.</p>	<p>Call the MILKchiller™ HOTLINE for service.</p>
<p>If the MILKchiller™ is turned off will I lose my settings?</p>	<p>No, the MILKchiller™ will have the same settings at the next start-up.</p>
<p>The display continues to flash “COOLING” 2 hours after powering ON the MILKchiller™.</p>	<p>Remove and discard the contents of the MILKchiller™. Turn the MILKchiller™ OFF, wait 3 seconds then turn ON. Use a new container of dairy product that has been refrigerated at the proper temperature. If problem persists, call the MILKchiller™ HOTLINE for service.</p>
<p>There was a power failure for 2 or more hours, is the milk safe?</p>	<p>It is recommended not to serve dairy products that have not been cooled for over 2 hours. If there is a power failure during business hours, remove the container from the chilling chamber and place in refrigerator. Turn the MILKchiller™ to OFF for the duration of the power failure. Please remember to remove the container from the chilling chamber and store it overnight in the refrigerator. This will avoid the dairy product spoiling overnight in the event of an extended power outage. Power ON the MILKchiller™ after the power has been restored.</p>
<p>When loading a ½ gallon carton, liquid escapes from the Disposable Straw.</p>	<p>Some ½ gallon containers are filled to the top, causing milk to escape. Pour out 2 oz. of liquid prior to inserting the Disposable Straw.</p>
<p>When the push button is pressed, the LOW indicator flashes, even with a full carton of dairy product installed.</p>	<p>This is normal, the force of pressing the push button triggers the LOW indicator. It will disappear when the push button is released, unless the liquid level is actually LOW.</p>

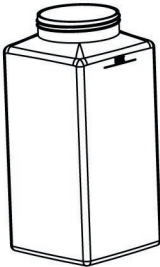
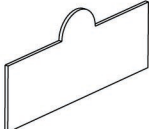
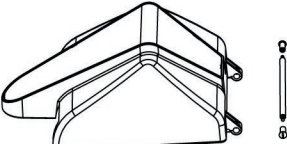
Contact Us

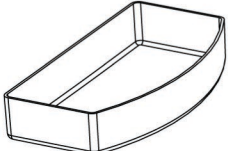
For questions about the MILKchiller™ appliance,
please call the MILKchiller™ TECHNICAL HOTLINE:
1-800-827-2582 ext. 2 or 704-329-5100 ext. 2
or send an email to
MILKchiller@frieling.com.

Item No.	UPC Code	Description	Image
0501	728547005011	MILKchiller with Black Housing	
0601	728547006018	MILKchiller with Stainless Steel Housing	
0701	728547070101	Disposable Straw for Paper Carton Package of 150	
0702	728547070200	Disposable Straw for Plastic Carton or MILKchiller™ Refillable Container Package of 150	
0704	728547070408	MILKchiller™ Refillable Container with Lid Package of 3	
0723	728547072303	Lid for MILKchiller™ Refillable Container	

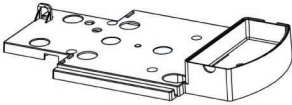
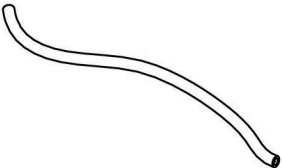
Item No.	UPC Code	Description	Image
0724	728547072402	MILKchiller™ Refillable Container	
0705	728547070507	Air Filter Pad Package of 4	
0706	728547070101	Lid Assembly Package including Lid Hinge Pin Assembly	
0707	728547070200	Lid Hinge Pin Assembly	
0710	728547071009	Drip Tray Insert	
0711	728547071108	Drip Tray Metal Platform	

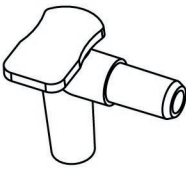
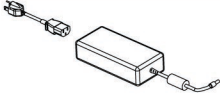
Item No.	UPC Code	Description	Image
0721	728547072105	Base with Drip Tray	
0722	728547072204	Drain Tube (per linear foot)	
0725	728547072501	Wire Tie	
0726	728547072600	Air Hose Fitting	
0713	728547071306	Power Supply with Cord	

Limited One Year Warranty

Warranty: This MILKchiller™ product is warranted by Frieling USA, Inc., to be free from defects in materials or workmanship for a period of one (1) year from the original purchase date. This product warranty covers only the original consumer purchaser of the product.

Warranty Coverage: This warranty is void if the product has been damaged during shipment, through unreasonable use, misuse, neglect, improper service, repairs by unauthorized personnel, normal wear and tear, improper assembly, installation or maintenance abuse or other causes not arising out of defects in materials or workmanship. This warranty is effective only if the product is purchased and operated in the USA, and does not extend to any units which have been used in violation of written instructions furnished with the product or to units which have been altered or modified or to damage to products or parts thereof.

Implied Warranties: ANY IMPLIED WARRANTIES WHICH THE PURCHASER MAY HAVE ARE LIMITED IN DURATION TO ONE (1) YEAR FROM THE DATE OF THE PURCHASE. Some states do not allow limitations on how long an implied warranty lasts, so the above limitation may not apply to you.

Warranty Performance: During the one-year warranty period, a product with a defect will be either repaired or replaced with a reconditioned comparable model (at our option) when the product is returned to the Service Center, or the purchase refunded. The repaired or replacement product will be in warranty for the balance of the one-year warranty period and an additional one-month period. No charge will be made for such repair or replacement.

Service and Repair: Should the appliance malfunction, please call toll-free 1-800-827-2582 ext. 2, or 704-329-5100 ext. 2, between the hours 8:00 AM and 4:00 PM EST, Monday through Friday. You may also email MILKchiller@frieling.com to report a problem.

In-Warranty Service (USA): For an appliance covered under the warranty period, no charge is made for service or return postage. Call for return authorization 1-800-827-2582 ext. 2.

Out-of Warranty Service: A service charge is made for out-of-warranty service. We will notify you of the amount of the charge for service and require you to pay in advance for the repair or replacement. Include \$25.00 USD for return ground shipping and handling.

Shipment: We cannot assume responsibility for loss or damage during incoming shipment. For your protection, carefully package the product for shipment and insure it with the carrier. Please return the appliance to us, prepaid, with the following items: return authorization number*, any accessories related to your problem, your full return address and daytime phone number, your email address, the best time/method to contact you, a note describing the problem you experienced, a copy of your sales receipt or other proof of purchase to determine the warranty status. C.O.D. shipments cannot be accepted.

*For return authorization, please call the MILKchiller™ TECHNICAL HOTLINE 1-800-827-2582 ext. 2, or send an email to MILKchiller@frieling.com.

Returned items without authorization code will be rejected.

Limitations of Remedies: No representative or person is authorized to assume for Frieling USA, Inc. any other liability in connection with the sale of our products. There shall be no claims for defects or failure of performance or product failure under any theory of tort, contract or commercial law including, but not limited to negligence, gross negligence, strict liability, breach of warranty and breach of contract. Repair, replacement or refund shall be the sole remedy of the purchaser under this warranty, and in no event shall Frieling USA, Inc. be liable for any incidental or consequential damages, losses or expenses. Some states do not allow the exclusion or limitation of incidental or consequential damages, so the above limitation or exclusion may not apply to you.

Legal Rights: This warranty gives you specific legal rights, and you may also have other rights which vary from state to state.

MILKchiller™ is a trademark of Frieling USA, Inc.
©2007 Frieling USA, Inc., All Rights Reserved

August 2007 Printed in China