

Project Name: _____ AIA#: _____

Model #: _____ Location: _____

SIS#: _____ Item #: _____ Quantity: _____



New Design!

Gas Countertop Griddles

It's what's INSIDE that counts!

Insulated double wall construction for superior heating efficiency.

GG36TG



Models

Manual Control

- GG15G GG24G
- GG36G GG48G

Thermostat Control

- GG24TG GG48TG
- GG36TG (pictured) GG60TG

Standard Features

- Efficient 1" thick highly polished steel griddle plate, fully welded to sleek stainless steel front plate and frame
- Insulated double wall front and side construction with extended cool-to-touch front edge
- High performance 30,000 BTU per burner
- Stainless steel U-style burners provide heat control every 12" and flame every 6"
- Individual adjustable pilot for each burner with easy front panel access
- Piezo ignition on thermostatic griddles
- 200°F - 575°F temperature range on the thermostatic griddle
- Removable, easy-to-clean, stainless steel catch tray
- Metal control knobs with set screws
- Adjustable 4" stainless steel legs
- Spatula wide 4" trough
- 3.5" tapered splash guard
- Unit ships natural gas with liquid propane gas (LP) conversion kit and regulator

Warranty

- Two years parts and labor



Approved by: _____ Date: _____



Gas Countertop Griddle

15" / 24" / 36" / 48" / 60" Models

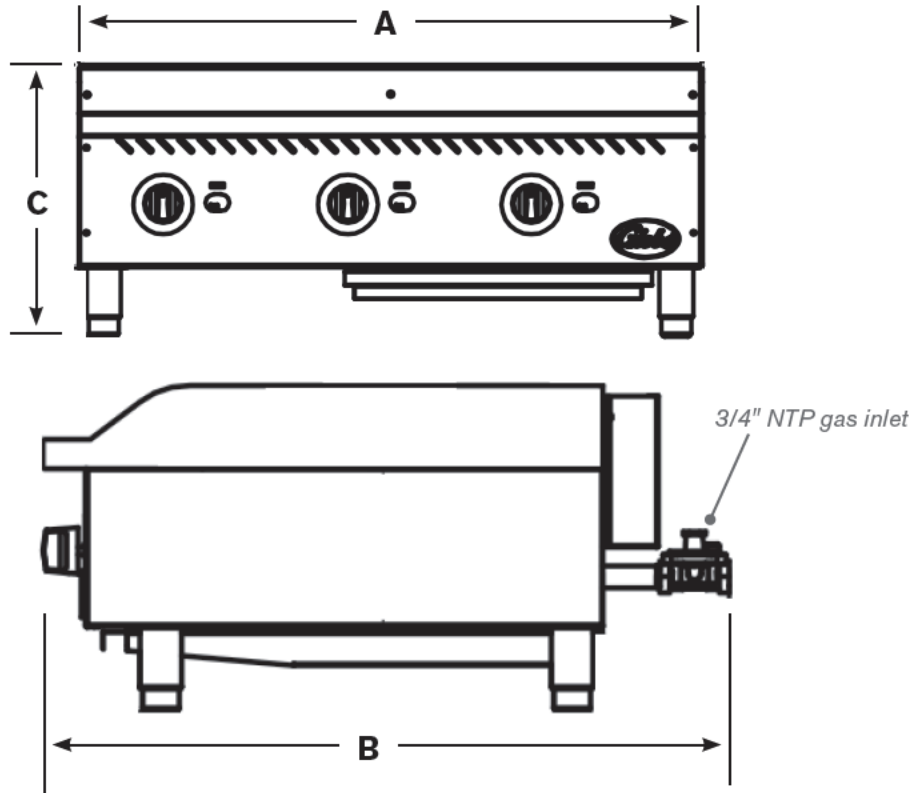

For indoor use only

DIMENSIONS | SPECIFICATIONS | SHIPPING INFORMATION

Reinforced carton for shipping. Weight of carton included below and may vary from shipment to shipment.
Shipped on a pallet. Freight class 85.

Model	A - Width	B - Depth <small>(Includes inlet pipe, back baffle, regulator)</small>	C - Height	Net Wt	No. Burners BTUs ea.	BTU	Cooking Area	Shipping Dimensions	Ship Wt
GG15G	15" (38 cm)	32.68" (83 cm)	15.75" (40 cm)	118.17 lbs (53.6 kg)	<u>1</u> 30,000	30,000	15" x 20" (38 cm x 51 cm)	48" x 40" x 23" (122 cm x 102 cm x 58.4 cm)	145 lbs (65.8 kg)
GG24G/ GG24TG	24" (61 cm)	32.68" (83 cm)	15.75" (40 cm)	163 lbs (81 kg)	<u>2</u> 30,000	60,000	24" x 20" (61 cm x 51 cm)	48" x 40" x 23" (122 cm x 102 cm x 58.4 cm)	210 lbs (95.3 kg)
GG36G/ GG36TG	36" (91.5 cm)	32.68" (83 cm)	15.75" (40 cm)	258 lbs (117 kg)	<u>3</u> 30,000	90,000	36" x 20" (91 cm x 51 cm)	48" x 40" x 23" (122 cm x 102 cm x 58.4 cm)	307 lbs (139.25 kg)
GG48G/ GG48TG	48" (122 cm)	32.68" (83 cm)	15.75" (40 cm)	337.75 lbs (153.2 kg)	<u>4</u> 30,000	120,000	48" x 20" (122 cm x 51 cm)	54" x 36" x 23" (137 cm x 91.4 cm x 58.4 cm)	397 lbs (180 kg)
GG60TG	60" (152.4 cm)	32.68" (83 cm)	15.75" (40 cm)	420.64 lbs (190.8 kg)	<u>5</u> 30,000	150,000	60" x 20" (152.4 cm x 50.8 cm)	62" x 36" x 23" (152.5 cm x 91.4 cm x 58.4 cm)	484.14 lbs (219.6 kg)

GAS REQUIREMENTS AND INFORMATION

- Natural gas or LP main supply required
- Conversion of unit from natural gas to LP must be completed by an authorized Globe servicer
- 3/4" standard pipe size I.D. connection

Gas griddle is constructed of stainless steel with extra-insulation in front and side walls; with cool-to-touch front edge. Griddle plate is 1" thick, highly polished steel with 3.5" tapered wraparound stainless steel splash guard. Griddle has a 4" wide front grease trough with grease chute and a stainless steel grease drawer with weep holes. Unit has high performance 30,000 BTU stainless steel U-style burners to provide flame every 6". A standing pilot is provided on manual control griddles, Pizio ignition provided on thermostatic griddles. Temperature range is 200° F to 575° F on thermostatic griddles. Gas connection is 3/4" N.P.T. males and a convertible pressure regulator is provided for either LP or natural gas. Griddle is listed to NSF Standard 4 by ETL. Two year parts and labor warranty.