



Project Name:	
Location:	
Item:	Qty:
Model:	

HUBM-2RB / HUBM-2FB / HUBM-3.5RB / HUBM-3.5FB

COUNTERTOP MERCHANDISERS



HUBM-2RB



HUBM-2FB



HUBM-3.5RB



HUBM-3.5FB

FEATURES

Hubert Merchandisers are designed for durability and visual appeal to increase the visibility of your product to promote sales and enhance profits. Featuring a bottom mounted compressor, the glass door merchandisers effectively keep product at exactly the right temperature while utilizing energy efficiency. The simple to use but precise digital controls allow for accurate and flexible use of the unit. For energy savings, durability, and visually appealing construction, Hubert Merchandisers are sure to be a hit.

- Black painted steel exterior and ABS interior are rugged and attractive
- LED lighted interiors brightly illuminate the interior
- Hinged glass doors with door lock standard
- Fully adjustable feet for convenience
- Freezers feature automatic defrost and refrigerators feature manual defrost
- Exterior digital temperature display can be recessed in top of unit or raised for easy viewing
- Freezers feature triple pane glass doors and refrigerators feature double pane glass doors
- Available in 120V/60Hz



Specifications subject to change without notice.

Approvals: UL, UL Sanitation Approved



HUBM-2RB / HUBM-2FB / HUBM-3.5RB / HUBM-3.5FB

COUNTERTOP MERCHANDISERS

DIMENSIONS

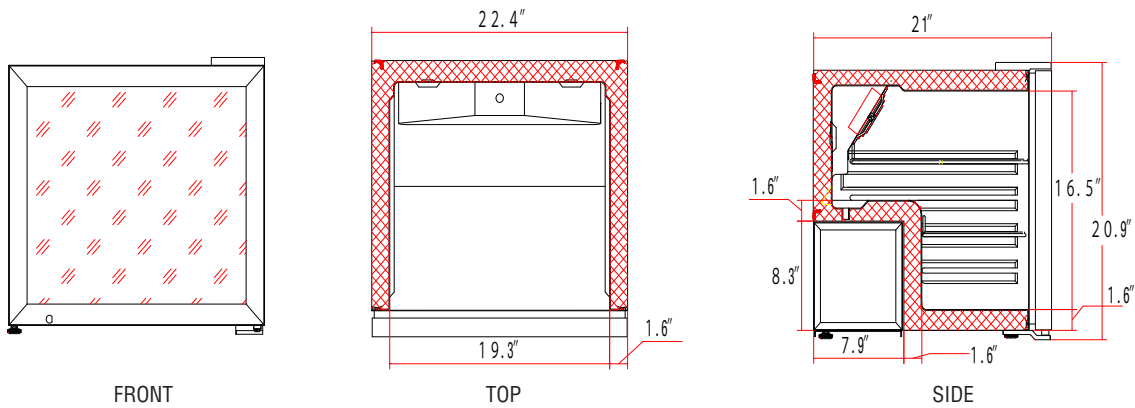

HUBM-2RB / HUBM-2FB

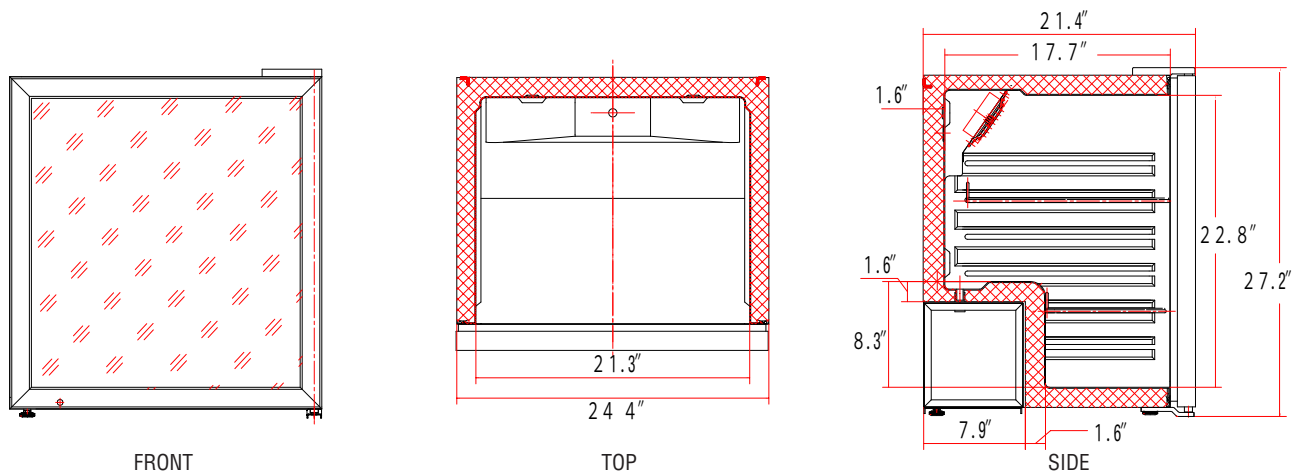

HUBM-3.5RB / HUBM-3.5FB

Model	Dim (W"xD"xH")	Capacity	Temp	Doors	Weight	Shelves
HUBM-2RB Refrigerator	22.4 x 21 x 21 570 x 533 x 530 mm	2.4 Cu Ft 67.96 L	35° to 41°F 1.7° to 5°C	1	88 lb 40 kg	2
HUBM-2FB Freezer	22.4 x 21 x 21 570 x 533 x 530 mm	1.7 Cu Ft 48.13 L	-3° to 0°F -19° to -17.8°C	1	88 lb 40 kg	2
HUBM-3.5RB Refrigerator	24.4 x 21.4 x 28 620 x 543 x 700 mm	4.1 Cu Ft 116.09 L	35° to 41°F 1.7° to 5°C	1	102 lb 46 kg	2
HUBM-3.5FB Freezer	24.4 x 21.4 x 28 620 x 543 x 700 mm	3.1 Cu Ft 87.78 L	-3° to 0°F -19° to -17.8°C	1	102 lb 46 kg	2