

# HUBERT®

Project \_\_\_\_\_  
 Item \_\_\_\_\_  
 Quantity \_\_\_\_\_  
 CSI Section 11400 \_\_\_\_\_  
 Approval \_\_\_\_\_  
 Date \_\_\_\_\_

Hubert LT

## Hubert LT



### Standard Features

- Automatic fill
- Push button start
- Labyrinth type door design
- Automatic pumped drain for floor and wall drain installations
- Fill and Dump design
- Stainless steel wash/rinse pump
- Universal Timer
- Delimiting cycle
- Simplified controls allow easy access for operation and service
- Door switch
- Low product indicator light
- One (1) each peg and combination rack included
- Above water scrap basket
- Built-in chemical pumps and priming switches

### Options

- Scale Prevention System (SPS)
- Replacement cartridge for SPS
- Water Hammer Arrestor
- Back Panel
- Tie Down
- 1500 Watt Sustaining Heater

### Accessories

- 36-Compartment Rack
  - 4-1/8" tall (105 mm)
  - 5-5/8" tall (143 mm)
  - 7" tall (178 mm)
- Combination Rack
- Peg Rack
- Machine Stand
  - 6" (152 mm) high
  - 18" (457 mm) high

## Specifications

Uses 1.2 gallons (4.5 liters) of water per rack  
 Uses 28.8 gallons (109 liters) of water per hour  
 Cleans 24 racks per hour  
 Two-minute automatic cycle  
 Powerful 1 hp wash pump motor  
 Air insulated between body and stainless steel housing  
 Durable stainless steel construction  
 Low product indicator light alerts operator when detergent and sanitizer are low

### Notes:

A vent hood is not recommended above the Hubert LT as it does not produce excessive vapors. Always check with the local building code to know what type of ventilation is required for commercial dish machine installations in your area.

Normal operation of the Hubert LT generates steam that may escape from the door. Materials such as wood laminate, veneers, etc. are unsuitable for use in areas exposed to dishwasher steam and detergents. Stainless steel or other moisture-resistant shields are recommended for surfaces adjacent to Hubert LT sides and top.



Intertek



# HUBERT®

# Hubert LT

**LEGEND:**

A - Water Inlet - 3/4" Male Garden Hose Connection (Connect to a true 1/2" ID water line)

B - Electrical Connection

C - Drain Connection - 6' coiled drain hose. Shipped inside machine. Must be installed no more than 24" AFF.

All dimensions from floor can be increased 1" with adjustable feet supplied.

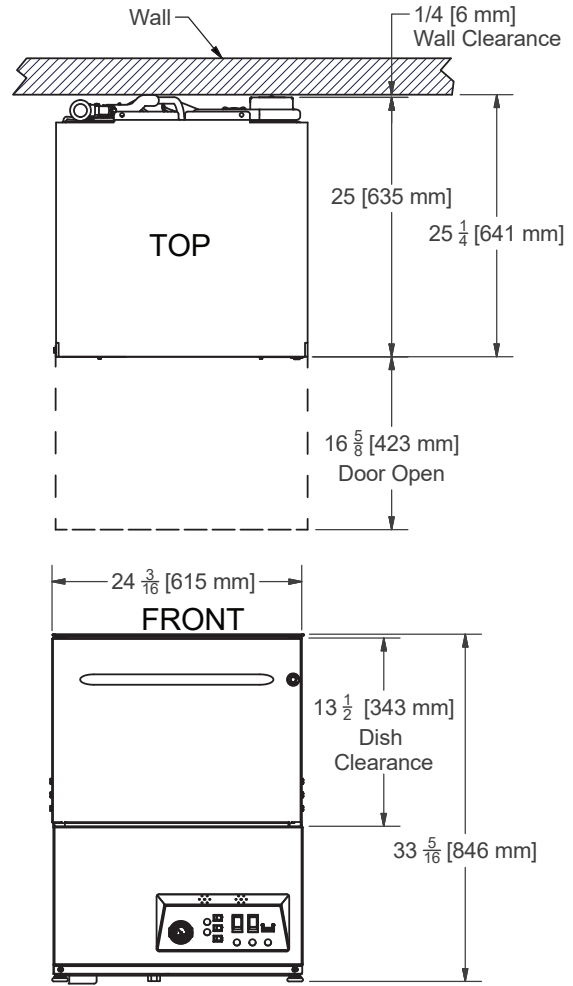
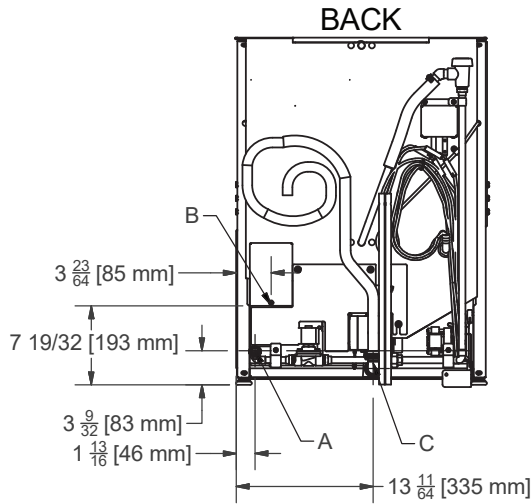

MODEL NO.	MACHINE DIMENSIONS				WALL CLEARANCE	SHIPPING INFORMATION					
	INSIDE CLEARANCE HEIGHT	INSIDE CLEARANCE WIDTH	INSIDE CLEARANCE DEPTH	DOOR OPEN DEPTH		WEIGHT	CLASS	CUBE	HEIGHT	WIDTH	DEPTH
Hubert LT	13-1/2" (343 mm)	20" (508 mm)	20" (508 mm)	42" (1067 mm)	1/4" (6 mm)	242 lbs (110 kg)	85	20.09 cu. ft.	43.5" (1105 mm)	28" (712 mm)	28.5" (724 mm)

APPROXIMATE TOTAL AMP LOADS	
115/60/1	13.2

OPERATING CAPACITY	
Racks per Hour	24
Dishes per Hour	600
Glasses per Hour	864

WASH PUMP MOTOR	
Wash Pump	1 hp

OPERATING CYCLE	
Wash Cycle (seconds)	56
Drain Time (seconds)	29
Rinse Cycle (seconds)	35
Total Cycle (seconds)	120

WATER REQUIREMENTS	
Gallons per Rack	1.2 gal (4.5 L)
Gallons per Hour	28.8 gal (109 L)
Flow Pressure (PSI)	15 - 25
Waterline Size (IPS)	3/4" Male GHT (connect to true 1/2" ID Line)
Drainline Size (OD)	1-3/8"

OPERATING TEMPERATURES	
Wash	120° F min. (49° C); 140° F (60° C) recommended
Rinse	120° F min. (49° C); 140° F (60° C) recommended

**HOW TO SPECIFY:** Hubert LT

**Hubert Company LLC**

Address: 9555 Dry Fork Road Harrison, OH 45030  
 Telephone: (800) 543-7374  
 Website: www.hubert.com  
 HUB-0002 [10/16/17]

*We reserve the right to change specifications in this bulletin without incurring any obligation for equipment previously or subsequently sold.*