



Warewashing Systems

# TempStar® with optional Ventless and Energy Recovery

Project \_\_\_\_\_

Item \_\_\_\_\_

Quantity \_\_\_\_\_

CSI Section 11400 \_\_\_\_\_

Approval \_\_\_\_\_

Date \_\_\_\_\_

TempStar® with optional Ventless and Energy Recovery

Models

TempStar®       TempStar® HH



### Standard Features\*

- Ventless: Does not require a hood
- Energy Recovery
- Internal condensing system minimizes water vapor
- Sani-Sure™ feature ensures proper rinse water temperature
- Multi-cycle timer (Extra Heavy, Heavy, Medium, Normal)
- Specially designed stainless steel nozzles provide superior cleaning action
- Auto-fill/auto-start
- Door switch
- Built-in pressure regulator and door interlock are standard
- Delime/manual wash switch
- Hi-limit thermostat and low water protection
- Uses standard 20" X 20" (508 mm X 508 mm) racks
- Detergent/rinse additive signal connection fuse box
- Self-draining stainless steel pump
- Built-in 70° F (38.9° C) rise booster heater
- Field convertible from straight through to corner and vice versa

### Mandatory Specs

- Specify:
- Electric
  - Steam
- Specify voltage \_\_\_\_\_
- Specify booster size \_\_\_\_\_

### Options

- 480V Electrical
- Single Phase
- Drain Quench System
- Scaltrol
- Water Hammer Arrestor
- Flanged Feet
- False Panel
- Steam Booster Heater
- Security Package

### Accessories

- 36-Compartment Rack
  - 4-1/8" tall (105 mm)
  - 5-5/8" tall (143 mm)
  - 7" tall (178 mm)
- Combination Rack
- Peg Rack

### Specifications

TempStar uses 0.89 gallons (3 liters) of water per rack; TempStar HH uses 1.36 gallons (5 liters) of water per rack

TempStar (normal) cycle time - 87 seconds\*

TempStar HH (normal) cycle time - 92 seconds\*

TempStar - 39 racks per hour (normal cycle)\*

TempStar HH - 37 racks per hour (normal cycle)\*

Single point connections for all utilities

Cold water connection only\*

Durable stainless steel construction

TempStar - 17.25" (438 mm) door opening accepts 18" (457 mm) trays

TempStar HH - 20.75" wide x 27" high (527 mm x 686 mm) opening accommodates 18"x 16" (457 mm x 660 mm) sheet pans and 60-quart mixing bowls

TempStar is field phase convertible

TempStar ships fully assembled



TempStar® is ENERGY STAR® qualified.  
TempStar® HH is not ENERGY STAR® qualified.

\*Specs shown for TempStar / TempStar HH with optional Ventless and Energy Recovery

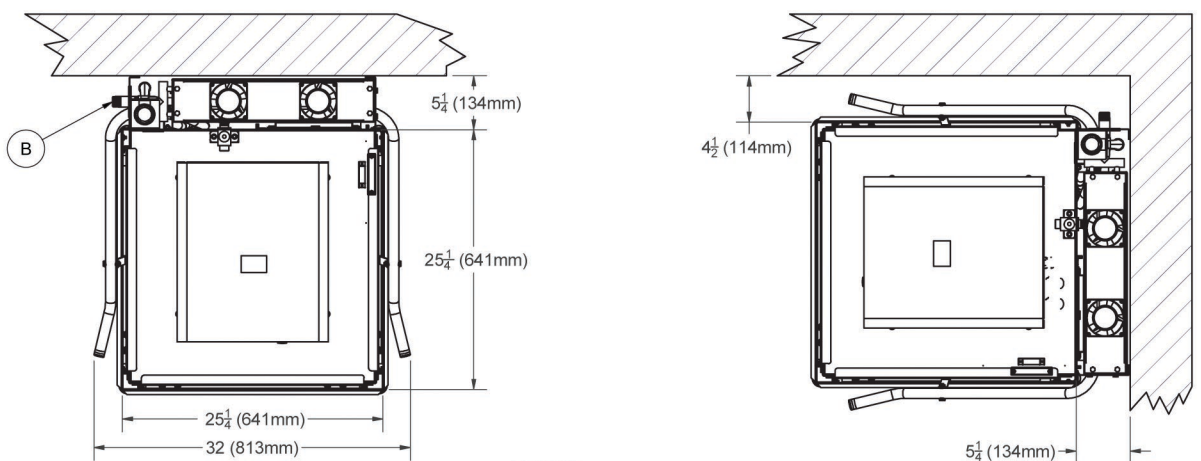
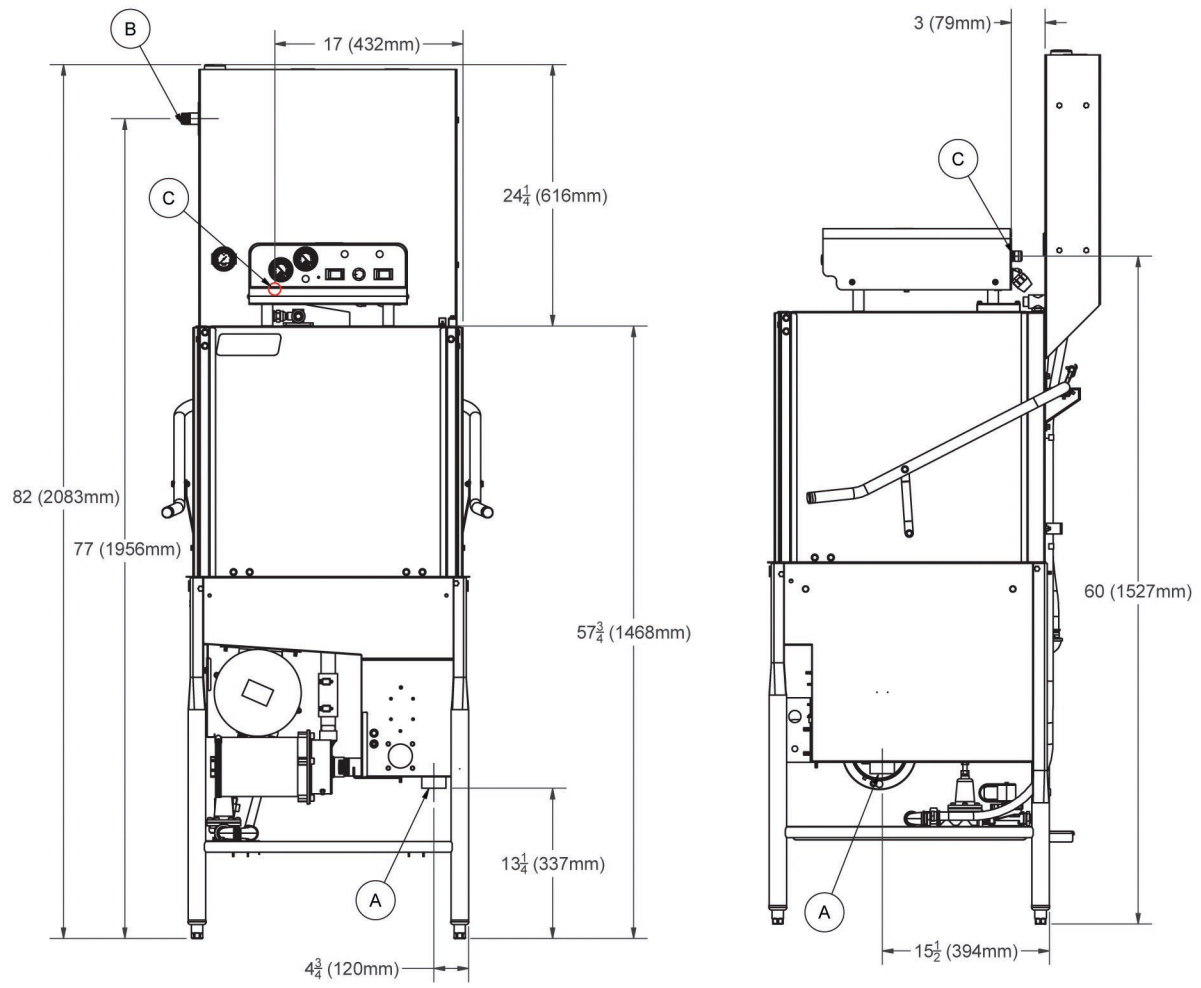

**LEGEND**  
 A) DRAIN 1/2 IPS  
 B) WATER INLET 3/4 MIP  
 C) ELECTRICAL CONNECTIONS

All vertical dimensions are ± 1/2" due to adjustable bullet feet

# TempStar® HH

TempStar® with optional Ventless and Energy Recovery

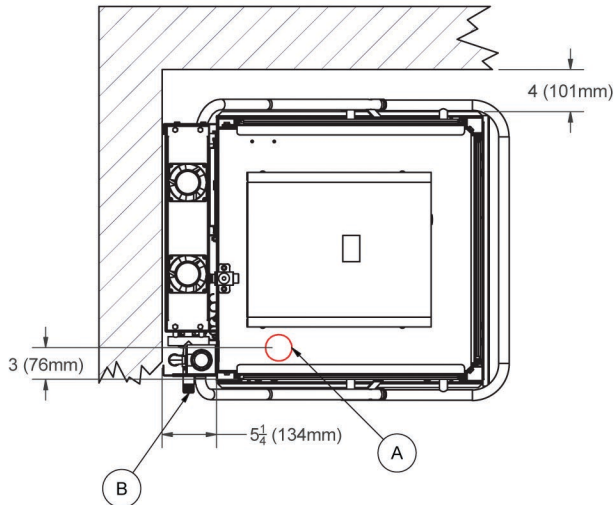
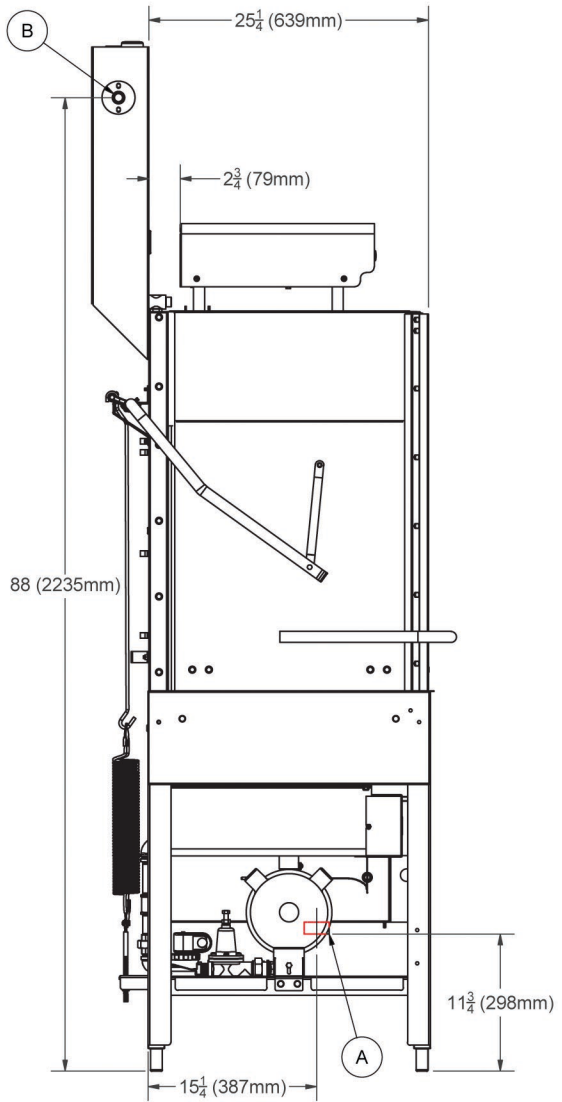
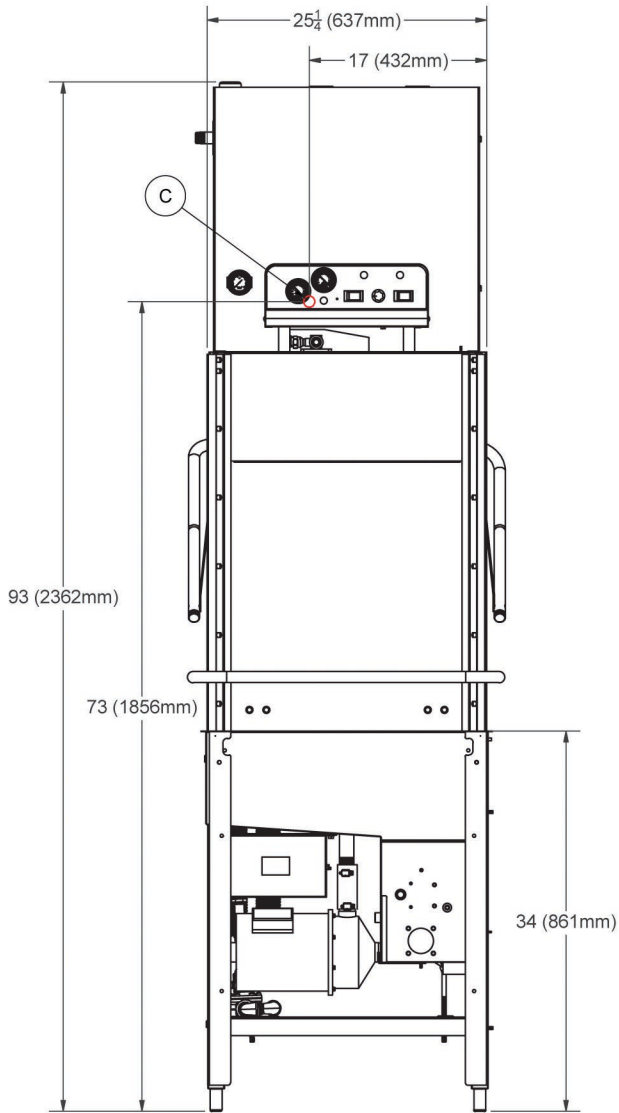

### LEGEND

- A) DRAIN 1 1/2 IPS
- B) WATER INLET 3/4 MIP
- C) ELECTRICAL CONNECTIONS

All vertical dimensions are ± 1/2" due to adjustable bullet feet



**Jackson**  
Warewashing Systems

TempStar® with optional Ventless and Energy Recovery

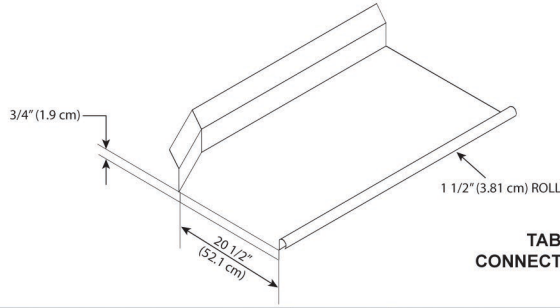

**TABLE DIMENSIONS  
CONNECTION TO DISHMACHINE**

MODEL NO.	MACHINE DIMENSIONS*				DRAIN HEIGHT	SHIPPING INFORMATION*					
	HEIGHT	WIDTH	DEPTH	DEPTH		WEIGHT	CLASS	CUBE	HEIGHT	WIDTH	DEPTH
TempStar**	82" (2083 mm)	25-1/4" (641 mm)	30-1/2" (775 mm)	13-1/4" (337 mm)	365 lbs (166 kg)	92.5	70.63 cu. ft.	86" (2184 mm)	33" (838 mm)	43" (1092 mm)	
TempStar® HH	93" (2362 mm)	25-1/4" (641 mm)	30-1/2" (775 mm)	11-3/4" (298 mm)	435 lbs (197 kg)	92.5	77.67 cu. ft.	83" (2108 mm)	33" (838 mm)	49" (1245 mm)	

DIMENSION REQUIREMENTS	
Wall Clearance (minimum)*	0" (0 mm)
Clearance above Heat Exchanger (minimum)*	6" (152 mm)
Standard Table Height	34" (864 mm)
Inside Vertical Clearance - TempStar	17-1/4" (438 mm)
Inside Vertical Clearance - TempStar HH	27" (686 mm)
Machine Height with Door Open - TempStar	76" (1933 mm)
Machine Height with Door Open - TempStar HH	86-3/4" (2202 mm)

OPERATING CAPACITY*				
	Normal	Medium	Heavy	Extra Heavy
Racks per Hour - TempStar	39	24	17	11
Racks per Hour - TempStar HH	37	23	17	11

OPERATING TEMPERATURES	
Wash (minimum)	150° F (66° C)
Rinse (minimum)	180° F (82° C)

TANK HEATER SPECIFICATIONS		
	Volts	KW
Electric Wash Tank Heater	208V	4.1
	230V	5.0
	460V	5.0
Electric Rinse Tank Heater - 70°F (38.9°C) Rise	208V	10.5
	230V	12.9
	460V	12.9

WASH PUMP MOTOR	
Wash Pump Motor - TempStar	1 hp
Wash Pump Motor - TempStar HH	2 hp

STEAM REQUIREMENTS	
Steam Flow Pressure (PSIG)	15-20
Consumption @ 15 PSIG (lbs/hr)	45

\*Specs shown for TempStar / TempStar HH with optional Ventless and Energy Recovery

HOW TO SPECIFY: TempStar® with optional Ventless & Energy Recovery  
 HOW TO SPECIFY: TempStar® HH with optional Ventless & Energy Recovery

WATER REQUIREMENTS	TempStar	TempStar HH
	Inlet Temperature*	40 - 90° F (4.4 - 32.2° C)
Gallons per Hour*	35 gal (133 L)	50 gal (189 L)
Gallons per Rack	0.89 gal (3 L)	1.36 gal (5 L)
Waterline Size MIP (minimum)*	3/4"	3/4"
Drainline Size IPS (minimum)	1- 1/2"	1- 1/2"
Flow Pressure (PSI) Connection	40	40
Operating Flow Pressure (PSI)	10	15 - 25
Wash Tank Capacity	8 gal (30 L)	8 gal (30 L)
Booster Tank Capacity	3 gal (11 L)	3 gal (11 L)

APPROXIMATE LOAD AMPS		
	TempStar	TempStar HH
Power Supply	AMPS	AMPS
208V/60HZ/1PH	75.8	87
208V/60HZ/3PH	46.3	55
230V/60HZ/1PH	83.6	96
230V/60HZ/3PH	50.7	61
460V/60HZ/3PH	24.1	28

OPERATING CYCLE FOR TEMPSTAR*					
	Wash	Rinse	Dwell	Condensate Removal	Total Cycle
Normal	40	13	4	30	87
Medium	100	13	4	30	147
Heavy	160	13	4	30	207
Extra Heavy	280	13	4	30	327

OPERATING CYCLE FOR TEMPSTAR HH*					
	Wash	Rinse	Dwell	Condensate Removal	Total Cycle
Normal	45	15	2	30	92
Medium	103	15	2	30	150
Heavy	163	15	2	30	210
Extra Heavy	283	15	2	30	330

AMBIENT HEAT LOAD	
Latent Heat (BTU)	5300
Sensible Heat (BTU)	4500

Jackson WWS, Inc.