

## SHARPENING INSTRUCTIONS

Your Hook-Eye Cutlery Sharpener is now ready for operation. **IMPORTANT:** Never operate or adjust unit with guards or covers removed. Always wear safety glasses. Optional Safety Shield removed in all photos for clarity.

To obtain professional results the first time, follow these instructions:

1. **CLEAN CUTLERY** first—remove all grease.
2. **SET LOWER GUIDE** Unit for bevel desired. Refer to Bevel Angle Guide Nameplate mounted on motor for proper settings.

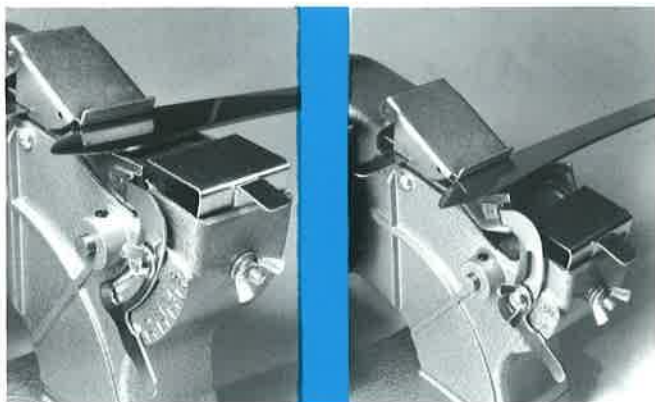

2-A. Setting guide in this position gives a long bevel to the edge.

2-B. The higher the guide is raised the more it shortens the bevel. This bevel also used for finishing edges.

3. **PLACE KNIFE FLAT ON LOWER GUIDE** and press lightly forward under the Upper Guide Unit. Upper Guide should always be locked in place.

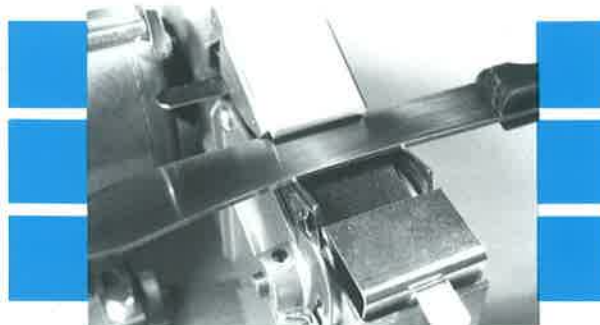

Back of blade must always be kept flat on lower guide.

4. **START AT HEEL OF BLADE** and draw steadily across to the point of the knife. The back of Knife must always be kept flat on the Lower Guide and be kept moving. No downward pressure is necessary.

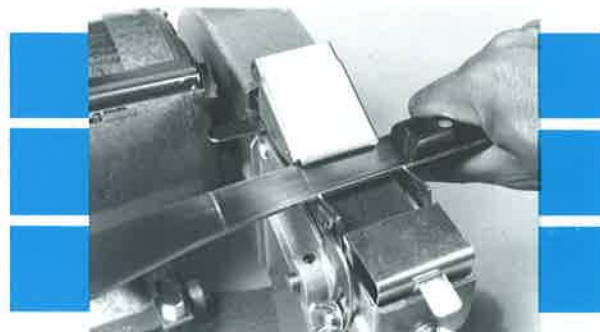

5. **FOLLOW THE SHAPE ON CURVED KNIVES** by turning body slightly as you draw knife across the Upper Guide.



6. **SHARPEN ONLY ENOUGH TO BRING BLADE TO SHARP EDGE** then finish with one very light stroke on each side of knife to hone it. Hone further with steel if desired.

Your Hook-Eye Cutlery Sharpener arrives properly adjusted from the factory. The motor position is factory set with two (2) hex head bolts. **DO NOT ADJUST THESE BOLTS.** Only the factory or a qualified Service Technician should attempt to align the motor.

## BELT CENTERING ADJUSTMENT

Occasionally on a new unit the belt may be out of alignment from shipping or periodically require re-alignment during operation. Re-alignment is simple.

1. While wearing safety glasses, plug unit into 120V grounded outlet and flip unit power switch to "ON" position.
2. Loosen Motor Toggle Eccentric Shaft Thumb Screw.
3. Rotate Motor Toggle Eccentric Shaft with motor running until belt centers between flanges on Idler Pulley. The belt should not touch flanged edges of pulley.
4. When belt is positioned, lock in place by tightening Motor Toggle Eccentric Shaft Thumb Screw.

## DUST DEFLECTOR ADJUSTMENT

The Waist-Line Dust Deflector Assembly is designed to contain most of the grit and filings created during sharpening.

1. Loosen thumb screw on front of belt housing.
2. Raise deflector to a height which contains debris but does not interfere with sharpening.
3. Tighten thumb screw to lock in desired position.

## KNIFE GUIDE TABLE REPLACEMENT



Replace when the Knife Guide Table becomes hollowed.

The only normal wearing part on the Hook-Eye Cutlery Sharpener is the #233 Knife Guide Table (under the belt) which becomes hollowed out during normal use. When the table becomes hollowed, a proper bevel cannot be obtained.

1. Make sure unit is unplugged.
2. Remove belt—see belt installation instructions for proper procedure. (Reverse steps)
3. Remove two (2) Phillips head screws that secure Knife Guide Table to unit.
4. Replace Knife Guide Table with new factory replacement part.
5. Secure with two Phillips head screws.
6. Re-install belt and Belt Housing Cover.

## Cutlery Sharpener For A Sharp Edge Every Time



**Sharp Cutlery  
All The  
Time With  
Hook-Eye's  
Cutlery  
Sharpener**

- 7½ ft. long electrical cord has 3-prong grounding plug
- Finish is attractive hammerloid gray
- Optional Safety Shield protects eyes (Not shown. Safety glasses should also be worn)
- Handle makes machine easy to move
- Belt presents true, flat surface

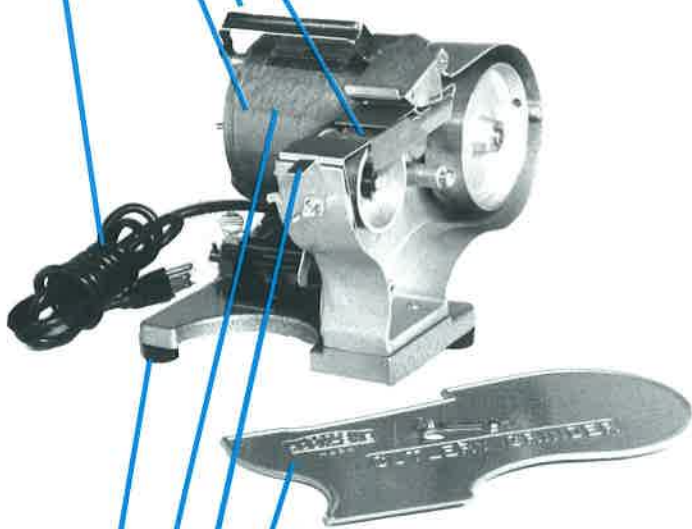

- Belt housing is easily removed
- Bevel guide is easily adjusted and locked
- Motor has sealed bearings... does not require oil. Available with a ¼ HP 110-120 volt 60 cycle AC single phase motor.
- Rubber feet provide safe, sure footing

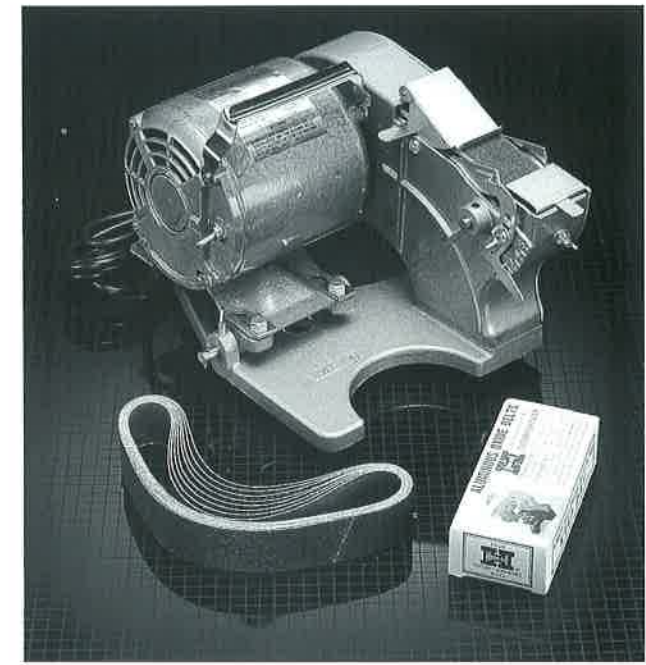
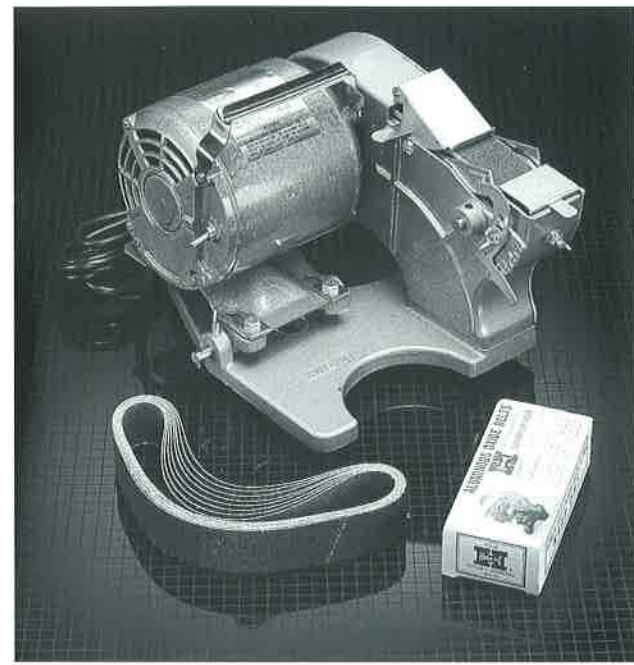

Made and Distributed by:



**U.S. Sales and Service Office:**  
1569 Tower Grove Avenue  
St. Louis, MO 63110

**Toll Free 800-325-8940**

**Operation  
Guide**



**THE HOOK-EYE CUTLERY SHARPENER:  
RUGGED... ACCURATE... CONVENIENT  
THE INDUSTRY STANDARD SINCE 1939**

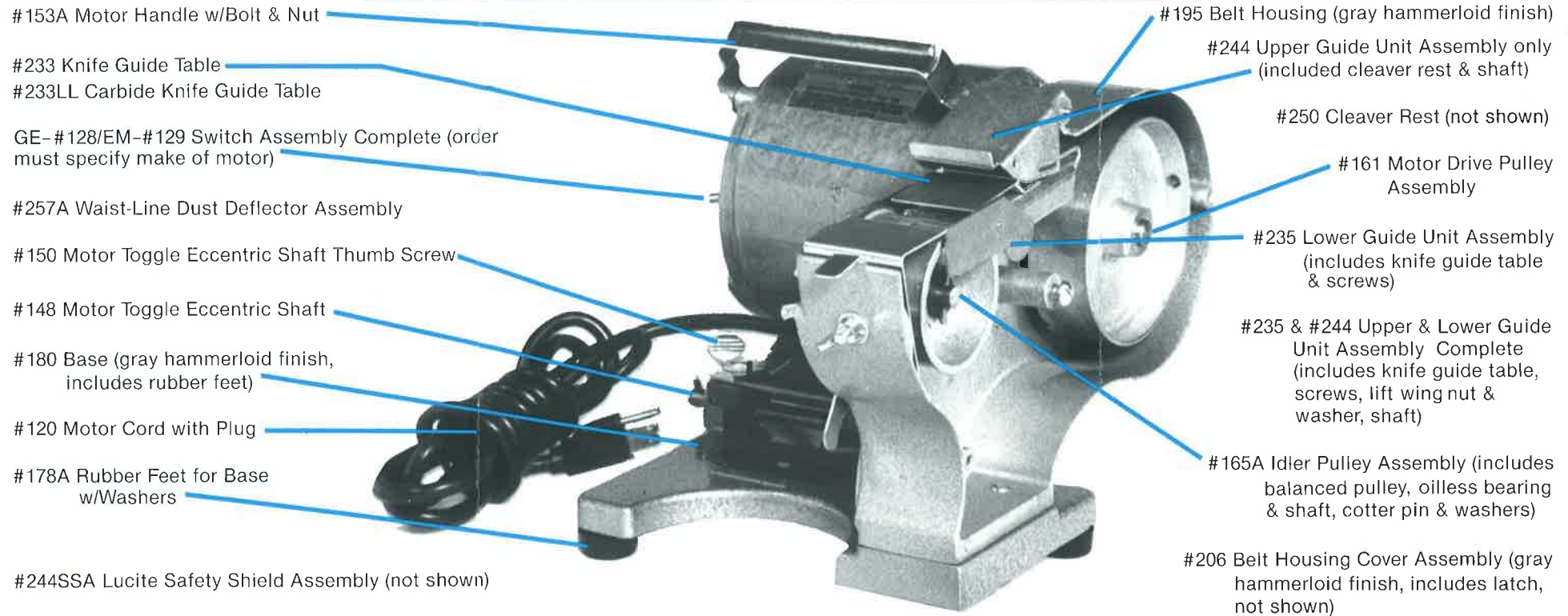

#153A Motor Handle w/Bolt & Nut

#233 Knife Guide Table

#233LL Carbide Knife Guide Table

GE- #128/EM-#129 Switch Assembly Complete (order must specify make of motor)

#257A Waist-Line Dust Deflector Assembly

#150 Motor Toggle Eccentric Shaft Thumb Screw

#148 Motor Toggle Eccentric Shaft

#180 Base (gray hammerloid finish, includes rubber feet)

#120 Motor Cord with Plug

#178A Rubber Feet for Base w/Washers

#244SSA Lucite Safety Shield Assembly (not shown)

#195 Belt Housing (gray hammerloid finish)

#244 Upper Guide Unit Assembly only (included cleaver rest & shaft)

#250 Cleaver Rest (not shown)

#161 Motor Drive Pulley Assembly

#235 Lower Guide Unit Assembly (includes knife guide table & screws)

#235 & #244 Upper & Lower Guide Unit Assembly Complete (includes knife guide table, screws, lift wing nut & washer, shaft)

#165A Idler Pulley Assembly (includes balanced pulley, oilless bearing & shaft, cotter pin & washers)

#206 Belt Housing Cover Assembly (gray hammerloid finish, includes latch, not shown)

**SAFETY WARNING**

- 1) Only trained personnel should operate machine.
- 2) Never operate or adjust machine with guards & covers removed. Always wear safety glasses.
- 3) Use only properly grounded 3 wire outlet. Work areas should be dry to prevent electrical shock.

**IMPORTANT!**

**PRECAUCIONES**

- 1) Nomas personas entrenadas deben de operar este maquina.
- 2) Nunca opere o ajustar la maquina sin las guias y tapaderas. Simpre use lentes de proteccion.
- 3) Use nomas una clavija trifasico—area de trabajo debe de estar seco para prevenir toques electricos.

**IMPORTANT!** To obtain the maximum performance from your Hook-Eye Cutlery Sharpener, read all instructions thoroughly, prior to operation.

**1. INSPECT PACKAGE CONTENTS.**

The Hook-Eye Cutlery Sharpener is designed for years of carefree performance and service. All units are warranted by the manufacturer to be free from defects in workmanship for ninety (90) days from date of purchase. Be sure to save the shipping carton and packing materials in the event the unit must be returned to the factory for servicing. Contents include:  
— One (1) Hook-Eye Cutlery Sharpener unit  
— One (1) box of four (4) 1 1/2" x 24" Aluminous Oxide Sharpener Belts

**2. REMOVE THE UNIT** from the box and place on a level surface.

**3. BELT INSTALLATION.**

For best results, use only Hook-Eye Heavy Duty Belts, available for the Hook-Eye Cutlery Sharpener.

- a) Make sure unit is unplugged.
- b) Lift latch on Belt Housing Cover and remove from unit. Remove any filings or debris from inside housing.
- c) Push Upper Guide Lock Lever forward and lift Upper Guide Unit Assembly out of way.
- d) Pull motor slightly forward with left hand to relieve tension on belt during belt replacement.
- e) Remove old belt from larger Motor Drive Pulley first, then off smaller Idler Pulley Assembly. (Not required on first time installation.)
- f) **IMPORTANT:** Position new belt so that arrow on inside of belt points in direction of rotation arrows on Motor Drive Pulley.



- g) Position new belt over smaller Idler Pulley first, then over larger Motor Drive Pulley.
- h) Release motor to original position to restore belt tension.
- i) Return Upper Guide Unit Assembly to original position. Pull Guide Lock Lever toward you to secure Upper Guide Unit.
- j) Replace Belt Housing Cover and latch in place.
- k) While wearing safety glasses, plug unit into 120V grounded outlet and flip unit power switch to "ON" position.
- l) Check if belt is centered on Idler Pulley Assembly. The belt should not touch flanged edges of pulley. Adjust if necessary (refer to "Belt Centering Adjustment" instructions).



## SHARPEN YOUR CUTLERY LIKE A PROFESSIONAL

- Make Your Cutlery Last Longer
- No Expense for Outside Grinding
- Save Time & Money

## WITH THE HOOK-EYE AUTOMATIC CUTLERY SHARPENER

The Hook-Eye Cutlery Sharpener is a compact, easy-to-use, heavy-duty machine that puts a professional edge on knives and cleavers in no time at all. It is the most practical, effective and versatile sharpener ever developed for users of sharp-edged tools. It eliminates laborious hand sharpening methods.

## PROFESSIONAL RESULTS EVERY TIME YOU SHARPEN

The skill is in the machine! No experience is needed. Adjustable bevel guide and blade guide insure the exact, consistent edge on every sharpening. Remove heavy nicks and restore a keen edge with an occasional light touch. No more waiting for costly, outside grinding services. Properly maintained blades last longer and reduce hand and wrist fatigue, too.

## LONG-LIFE, TROUBLE-FREE SHARPENING BELT



Unlike other motor-driven sharpeners, the Hook-Eye Cutlery Sharpener uses a belt instead of ordinary abrasive wheels or stones which change size or shape as they wear. This belt always presents a true, flat surface to the edge being sharpened. It needs no dressing by a skilled mechanic and will not heat up under constant operation.

## DIAL THE BEVEL YOU LIKE

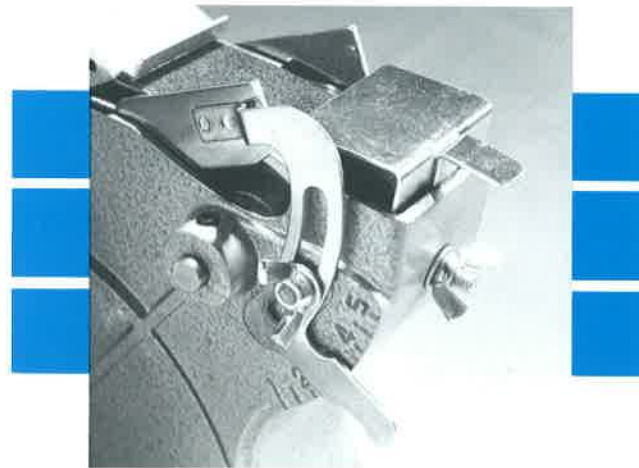

An adjustable, numbered guide holds the blade at the selected angle. Quickly adjusts for long, flat, sloping edges on knives and a short, sharp angled edge on cleavers. Or a combination of flat bevel and a sharp angle at the very edge can be obtained just by adjusting the numbered guide.

## BELT TENSION REGULATED AUTOMATICALLY

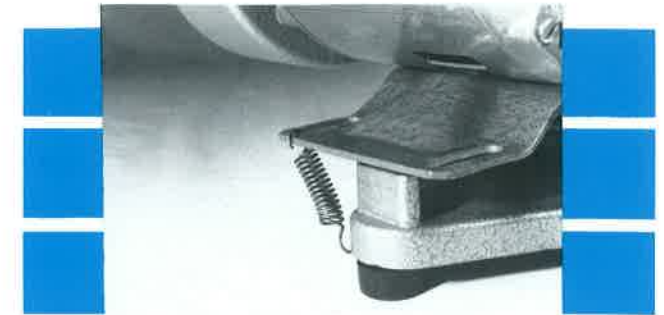

A spring-loaded tension regulator eliminates the necessity of adjustment of belt tension.

## EASILY PORTABLE... KEEP IT NEAR WORK AREA

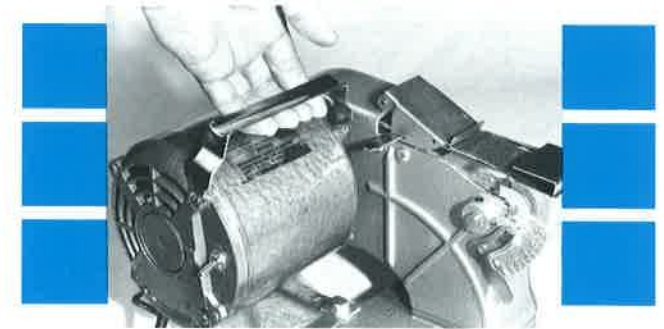

A comfortable, sturdy handle permits easy, balanced handling of the unit. Requiring only 12 square inches of space, place it near the cutting table or knife-sharpening shelf for quick touch-up of dull knives or cleavers.

## PROFESSIONAL RESULTS RIGHT FROM THE START



With the Hook-Eye adjustable blade guide, knife sharpening is easy. Reshape a damaged edge, sharpen a dull knife, or make a quick touch-up, it's all easy.