

Nesting Work Table

Parts List & Assembly Instructions

NOTE: Please refer to Drawings & Parts List for quantities and descriptions before starting.

Tools needed: Phillips Head screwdriver, two 10MM wrenches & one 17MM wrench, or 2 adjustable wrenches

STEP 1: Attach Top and Middle Cross Braces with Bracket holes facing up to T-Frames using (4) 1&5/8" Black Bolts and Lock Nuts. Do not tighten until Bottom Cross Brace is installed (see drawing).

STEP 2: Attach Bottom Cross Brace using (2) 1&5/8" Black Bolts and Lock Nuts in (2) horizontal holes at bottom of T-Frames. Tighten Top, Middle and Bottom Cross Braces until snug (see drawing).

STEP 3: Install (4) Casters and (4) Bumpers by sliding Bumpers over Caster stems then inserting Caster stems through the Pre-set holes on all (4) bottom corners of T-Frames. Tighten large Caster Lock Nuts on Caster Stem until snug.

STEP 4: Position flat side of (2) Angled U-Channels on underside of Grey Wood Top indicated by (6) pre-set holes with threaded inserts so that narrow end of Angled U-Channel is closest to Wood Top Edge (see drawing). Using (6) Phillip head screws, install both Angled U-Channels in pre-set holes of Grey Wood Top until snug. Do not over-tighten.

STEP 5: Install (2) Rectangle U-Channels to Top Cross Brace's pre-set Brackets with flat side of U-Channel facing up. Insert Codder Bolt through U-Channel and Bracket to hold in place. Then secure by inserting Pin in hole of Codder Bolt. Install remaining (2) Rectangle U-Channels to Middle Cross Brace's pre-set Brackets using Codder Bolts and Pins. Important: All Rectangle U-Channels should be installed on same side of unit.

STEP 6: Install Grey Wood Top to Top Cross Brace. Hold Wood Top so that Angled U-Channels are facing Brackets with Angled U-Channels facing down. Line up slots of Angled U-Channels with holes in Brackets. Hold in place and insert Codder Bolts, then secure with Pins. Install Black Shelf to Middle Cross Brace on same side of unit as Grey Wood Top using same procedures as Grey Wood Top installation.

STEP 7: Install Telescoping Hanger Bar to either side of T-Frames. First install Outer Sleeve with adjustment holes closest to Top Cross Brace. Line up Outer Sleeve tabs so they overlap corresponding T-Frame holes located between Top and Middle Cross Braces. Using Black Bolts and Lock Nuts secure in place. Attach Hanger Bar to Inner Sleeve using Push Pin closest to Inner Sleeve end. Slide opposite end of Inner Sleeve into Outer Sleeve so that remaining Push Pin lines up with Outer Sleeve adjustment holes until it clicks in place at desired height. Note: Hanger Bar can be installed in all four directions as desired. When not in use, position Hanger Bar so that bar extends inward over Wood Top for safety.

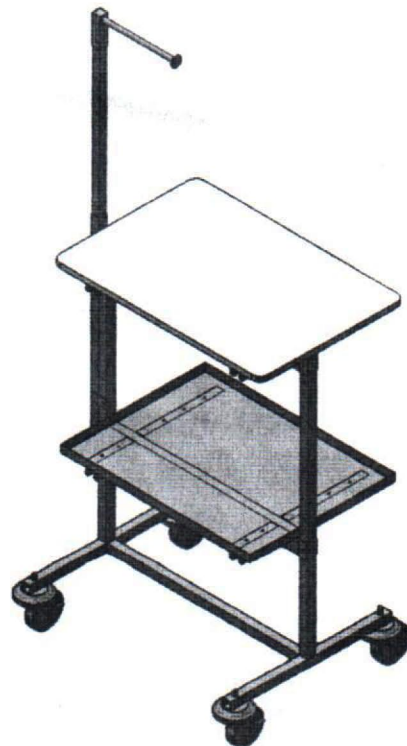
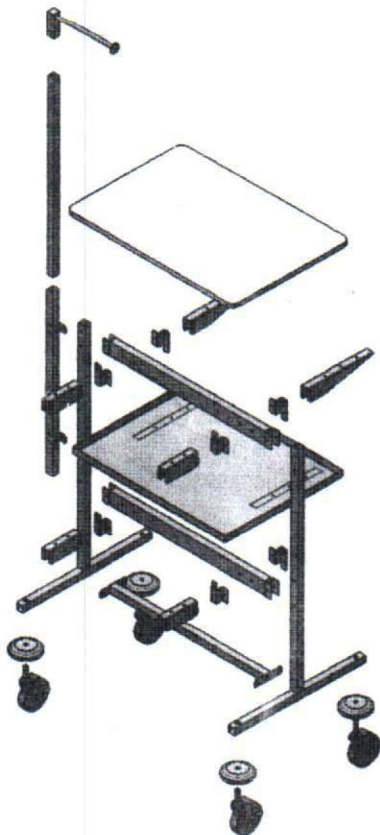

T-Frame, QTY 2



Top And Middle Cross Brace, QTY 2

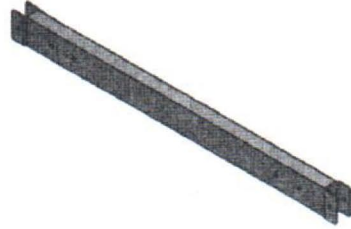

Bottom Cross Brace, QTY 1

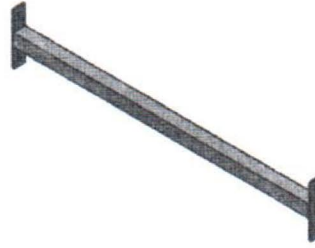

Telescoping Hanger Bar "Outer Sleeve", QTY 1



Hanger Bar, QTY 1



Telescoping Hanger Bar "Inner Sleeve", QTY 1



Black Shelf, QTY 1

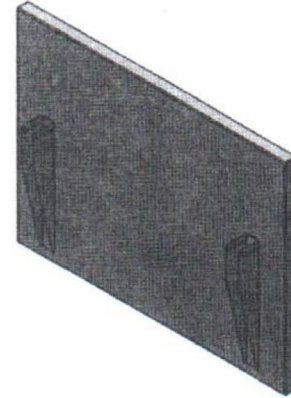

Angled U-Channel, QTY 2

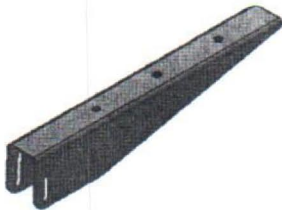

Rectangle U-Channel, QTY 4

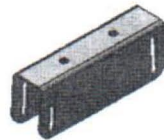

Brackets (Pre Assembled) QTY 8

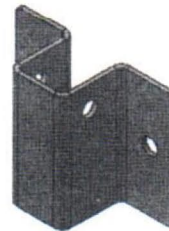

Grey Wood Top, QTY 1

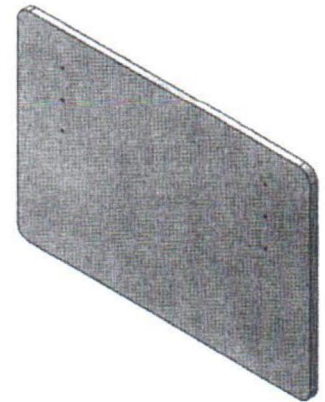

Other Hardware:



Black Lock Nut
QTY 10
Silver Lock Nut (Pre Assembled)
QTY 8



1 5/8" Black Bolt
QTY 10
1 5/8" Silver Bolt (Pre Assembled)
QTY 8



Caster Lock Nut
QTY 4



Phillips Head Screws
QTY 6



Bumpers
QTY 4



Caster Without Brake
QTY 2



Caster With Brake
QTY 2



Copper Bolt
QTY 8



Pin
QTY 8