

JOB:

ITEM #:

QUANTITY:



Equipment Stand

EQUIPMENT STAND

Holds Practically Anything!

This all purpose stand is perfect for microwaves, mixers, can openers, meat grinders, etc... Removable aluminum, or stainless steel, top and optional undershelf lift off for easy cleaning and are fully supported by the all welded, heavy duty frame. Adjustable feet allow for quick stabilization and easy leveling. With a **weight capacity of 1000#** it is hard to find something this little stand won't hold.

Sanitary

Each unit is all welded with all seams fully welded and sealed providing a smooth, easy to clean surface. No cracks or crevices to trap dirt!

Guaranteed

Like all of our products, the equipment stand is built to last... We Guarantee It! Each unit carries a **Lifetime Guarantee** against rust and corrosion as well as a **Five-Year Guarantee** against material defects and workmanship.



Equipment Stand
With Optional Undershelf



NSF Certified

0503



Aluminum Food Handling, Storage, & Transport Solutions

New Age Industrial Corp., Inc. • 1000 E Hwy-36 • PO Box 520 • Norton, Kansas 67654

Phone#: 800.255.0104 • 785.877.5121 • Fax#: 877.877.7687 • 785.877.2616 • www.newageindustrial.com

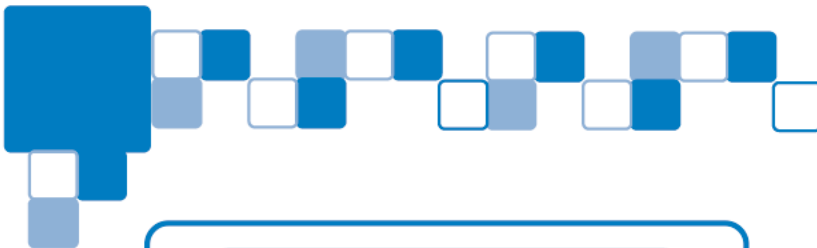

**E
Q
U
I
P
M
E
N
T

S
T
A
N
D**

JOB:
ITEM #:
QUANTITY:

SPECIFICATIONS

DIMENSIONS: 24"W x 24"H x 29"L

CONSTRUCTION: Corrosion resistant, rust proof, all welded tubular framework. Primary type 6063-T5 aluminum alloy.

TOP:

STAINLESS STEEL TOP-Model #24ESS29
16GA Stainless Steel with 1" lips down, corners sealed.

ALUMINUM TOP - Model #24ESA29
.080" aluminum sheet with 1" lips down, corners sealed.

FRAME: 1-1/2" x 1-1/2" x .070" wall tubing used throughout.

ADJUSTABLE FEET: Four NSF Certified adjustable feet.

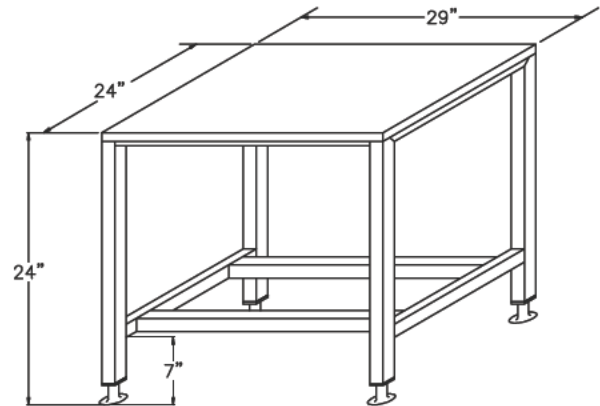

Ordering In

Model No.	Size W-H-D	Top Style	Ship Wt.
◦ 24ESS29 24" x 24" x 29" Stainless 31#
◦ 24ESA29 24" x 24" x 29" Aluminum 23#

Units equipped with NSF Certified adjustable feet.

◦ *All Items Are UPS-able*

OPTIONS:

Aluminum Undershelf - Add "US" suffix to model #.

Casters - Add suffix "999" to model #.

- All swivel with brake (#C447).
- Height with casters = 24".

Aluminum Food Handling, Storage, & Transport Solutions

PHONE#: 800.255.0104 • 785.877.5121 • FAX#: 877.877.7687 • 785.877.2616