

Project: \_\_\_\_\_

Item: \_\_\_\_\_

Quantity: \_\_\_\_\_

## Pan Dollies



1192



1193



1194

### Stores Up To 75 Bun Pans!

Heavy duty Pan Dollies are ideal for transporting and storing 18" x 26" sheet pans. Indispensable for any bakery or food preparation area these racks are guaranteed to last.

- Handles and side supports of 1" square tube with rounded corners ensures the strength and rigidity of the frame and are easy on the hands of the operator.
- Equipped with four 5" plate type heavy duty swivel casters, these all welded aluminum dollies are built to be loaded up and pushed around..
- Each unit is all welded with all seams fully welded and sealed providing a smooth, easy to clean surface – No cracks or crevices to trap dirt!
- **Lifetime Guarantee** against rust and corrosion.
- **Five-Year Guarantee** against material defects and workmanship.
- **NSF Certified.**



New Age Industrial Corp., Inc. || [NewAgeIndustrial.com](http://NewAgeIndustrial.com) || Made in the USA 

PO Box 520 • 16788 US Hwy 36 • Norton, Kansas 67654 || Phone: (800) 255-0104 • (785) 877-5121 || Fax: (877)-877-7687 • (785) 877-2616

This information is for general sales and engineering use only. New Age Industrial reserves the right to modify or make changes at any time, without notice, to materials and specifications.

Project: \_\_\_\_\_

Item: \_\_\_\_\_

Quantity: \_\_\_\_\_

## Pan Dollies

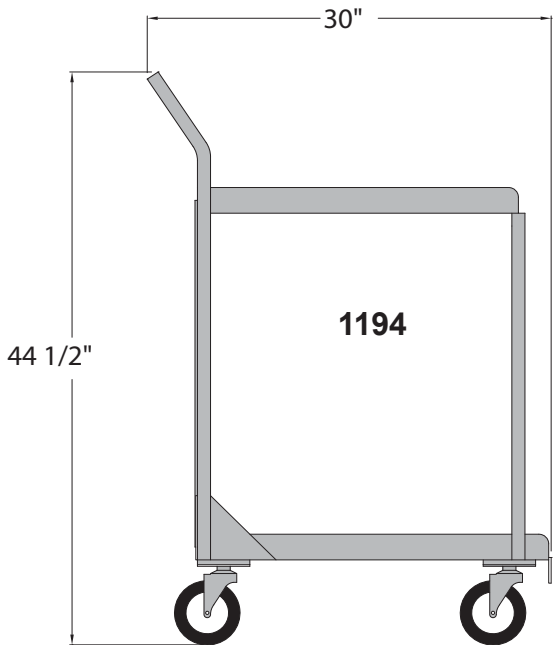
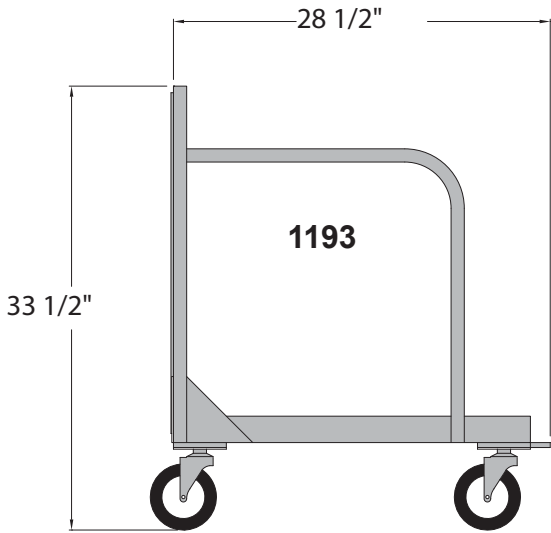

### MATERIAL:

- Framework is constructed of 2" x 2" x .125" wall angle.

### Models #1193 and #1194:

- Handles and sides are constructed of 1" x 1" x .070" wall tubing.

### CASTERS:

- Equipped with four 5" platform type swivel casters.

### GUARANTEE:

- Lifetime Guarantee against rust and corrosion.
- Five-Year Guarantee against workmanship and material defects.

### NSF Certified.

### ► Pan Dollies

Model No.	Size W-H-D	Weight Capacity	Ship Lbs.
<b>Angle Dolly Without Sides or Handle</b>			
1192	18 <sup>7</sup> / <sub>8</sub> " x 7" x 27"	800 lbs.	18
<b>Angle Dolly With Sides &amp; Handle</b>			
1193	21" x 33 <sup>1</sup> / <sub>2</sub> " x 28 <sup>1</sup> / <sub>2</sub> "	900 lbs.	25
<b>Two Tier Angle Dolly With Sides &amp; Handle</b>			
1194	21" x 44 <sup>1</sup> / <sub>2</sub> " x 30"	900 lbs.	33

Four 5" plate type swivel casters.

Accommodates 18" x 26" sheet pans.

### Options:

- Caster Locks (2)** - Add "CL" suffix to model #.
- Medical Caster Upgrade** - Add "MD" suffix to model #.
- Prison Package** - Add "PP" suffix to model #.  
- Tamper resistant screws.

### Aluminum Drag Hook - Not NSF Certified.

1199	37 <sup>1</sup> / <sub>2</sub> " Long	1
------	---------------------------------------	---



New Age Industrial Corp., Inc. || [NewAgeIndustrial.com](http://NewAgeIndustrial.com) || Made in the USA

PO Box 520 • 16788 US Hwy 36 • Norton, Kansas 67654 || Phone: (800) 255-0104 • (785) 877-5121 || Fax: (877)-877-7687 • (785) 877-2616

This information is for general sales and engineering use only. New Age Industrial reserves the right to modify or make changes at any time, without notice, to materials and specifications.