



Job:

Item No.

Countertop Oven

MODEL: NCO5



DIMENSIONS & SHIPPING WEIGHT

29 1/8" W X 27 7/8" D X 26 7/8" H
(740 mm X 708 mm X 683 mm)
180 lb (82 kg)

ELECTRICAL SYSTEM

1 Phase:

208V - 21 A - 4 kW - 60 Hz - 2 wires + ground

240V - 18 A - 4 kW - 60 Hz - 2 wires + ground

CAPACITY

5 Half Size Sheet Pans (13" x 18" - 330mm x 457mm)

Shelf Spacing: 3 1/8" (89 mm)

FINISH

Stainless Steel

FEATURES & BENEFITS

- Electromechanical controls
- Temperature up to 475°F (246°C)
- Indicator light for thermostat
- Door switch cutoff for fan blower
- Stainless steel construction
- 4" adjustable legs (102 mm)
- Press-fit removable door gasket for easy cleaning
- One-handed door handle operation
- Cool touch door with dual thermal wide view glass
- Lift up removable side racks
- Adjustable buzzer noise

OPTIONS & ACCESSORIES

- Wire Shelf (98-1227-A)
- Equipment Stand (98-9450)

STANDARD PRODUCT WARRANTY

One Year Labor & Two Year Parts

SHORT SPECIFICATION

Countertop Oven, Electric, Electromechanical Control, 4" Adjustable Legs, Left Hinge, Cool To Touch Door, Stainless Steel Construction Interior & Exterior, Slam Cam Handle, Stackable Without Hardware, 4 kW, ETL & NSF Certified

DRAWINGS

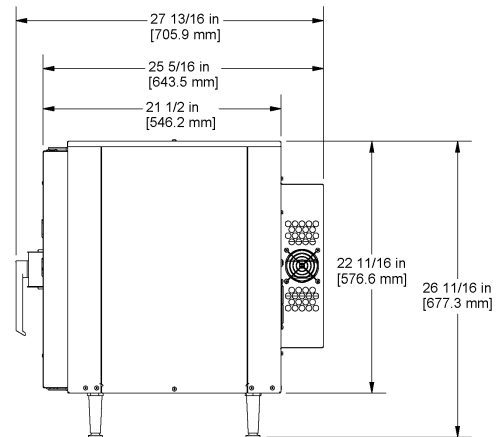
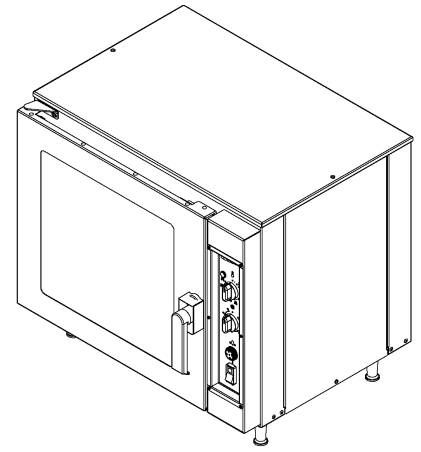
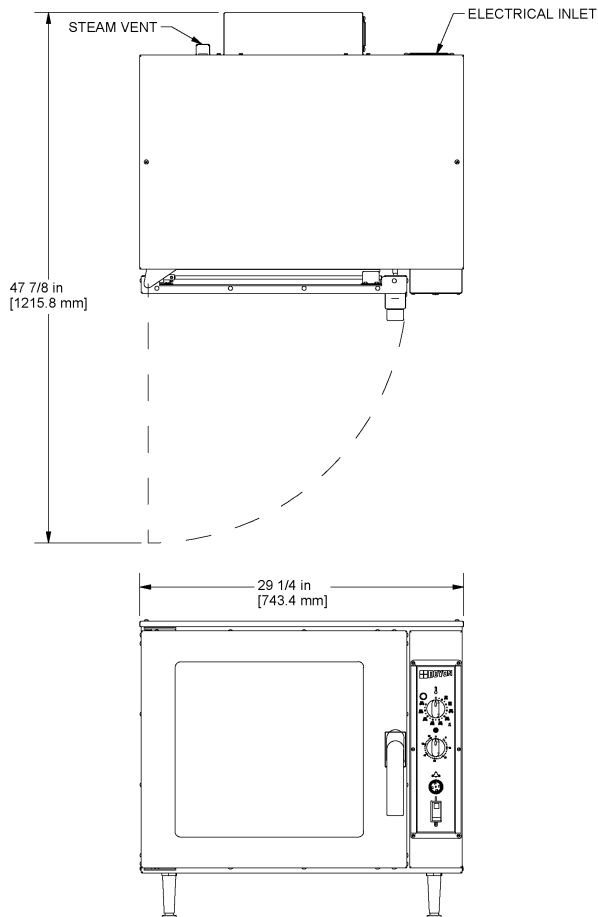

PRODUCTION CAPACITY

Product (Fresh State)	Bake Time	Bake Temp (°F)	Bake Temp (°C)	Quantity Produced
9" Cakes	18 - 22 minute	350	177	15
9" Pies	30 - 35 minute	375	190	10
Bagels (8 per half pan)	15 minute	350	177	n/r
Dinner Rolls (8 per half pan)	15 - 18 minute	350	177	128
Sub Rolls 12" (5 per half pan)	15 - 18 minute	350	177	100
French Baguettes (5 per pan)	20 - 25 minute	350	177	n/r
Croissants (15 per pan)	12 - 15 minute	350	177	n/r
Muffins (12 per pan)	18 - 22 minute	325	163	180
Muffins (24 per pan)	18 - 22 minute	325	163	n/r
9" Quiches	30 - 35 minute	350	177	15
Cookies (9 per half pan)	8 - 10 minute	300	149	270
Danish (7 per pan)	12 - 15 minute	350	177	175
Biscuits (7 per half pan)	8 - 10 minute	350	177	210
Bread (4 strapped pan)	30 - 35 minute	375	190	n/r
Cinnamon Rolls (8/half pans)	15 - 18 minute	325	163	160
Brownies (16 1/2oz box)	12 minute	350	177	25

*Capacities are per hour



5600 13th Street
 Menominee, MI 49858
 sales@nu-vu.com
 (800) 338-9886 Toll Free
 (906) 843-4401 Phone
 (906) 863-5889 Fax
 www.nu-vu.com

SPECIFICATIONS SUBJECT TO CHANGE WITHOUT NOTICE

KCL & REVIT DRAWINGS UPON REQUEST

Rev 1—2/16/2017