



C0830 - 800lb Cube Ice Machine

Prodigy Plus® Modular Cube Ice Machine

The world's smartest cuber.

As the world's only self-monitoring cuber, the new Scotsman Prodigy Plus® cube ice machines make it easier than ever to maintain your equipment and save money. Whether it's the advanced ice level control or an optional feature board for quick diagnostics, this is ice-making re-imagined. And with intuitive technology like AutoAlert™ indicator lights, a reduced operational footprint and easy-access service from the front panel, Prodigy Plus® cubers are simply the smartest, most reliable way to create fresh-tasting ice — every time.



The Prodigy Plus® difference.

- AutoAlert™ indicator lights for better visibility
- Operational footprint among the industry's smallest
- Industry-exclusive QR code instantly connects users to service information and warranty history
- One-touch cleaning reduces labor costs and saves time
- Front-located air filter for more efficient operation
- Self-aligning front panel for easy access to key components
- Patented WaterSense purge control automatically reduces scale buildup
- Patented Harvest Assist efficiently moves cube ice to the bin
- Smart-Board™ advanced feature module available for additional diagnostic capabilities
- Optional Vari-Smart™ ice level control allows operators to customize ice levels
- Antimicrobial protection guards internal surfaces between cleanings
- A full range of water- and energy-saving features

C0830 - 800lb Cube Ice Machine



B530P



B530S



24 Hour Volume Production

Air Cooled		Remote		Water Cooled	
70°F/21°C 50°F/10°C	Air Water	90°F/32°C 70°F/21°C	70°F/21°C 50°F/10°C	Air Water	90°F/32°C 70°F/21°C
905/411 lb/kg		724/329 lb/kg	870/395 lb/kg		924/420 lb/kg



B842S



Modular Bin Options

Model Number*	Dimensions W" x D" x H"	AHRI Certified Bin Capacity lb/kg	Application Capacity lb/kg	Finish	Ship Weight lb/kg
B530P	30 x 34 x 44**	420/191	536/244	Poly	150/68
B530S	30 x 34 x 44**	420/191	536/244	Metallic	150/68
B842S	42 x 34 x 44**	610/277	778/353	Metallic	185/84

* Contact Scotsman for bin top requirements. ** Add 6" Height for bin legs.



Cube Ice

Common ice form, ideal for mixed drinks.



Small Cube
7/8" x 7/8" x 3/8"
(2.22 x 2.22 x .95 cm)



Medium Cube
7/8" x 7/8" x 7/8"
(2.22 x 2.22 x 2.22 cm)



Certification



Warranty

- 3 years parts and labor on all components.
- 5 years parts and labor on the evaporator.
- 5 years parts on the compressor and condenser.

Warranty valid in North, South & Central America. Contact factory for warranty in other regions.

C0830 - 800lb Cube Ice Machine

Prodigy Plus® Modular Cube Ice Machine

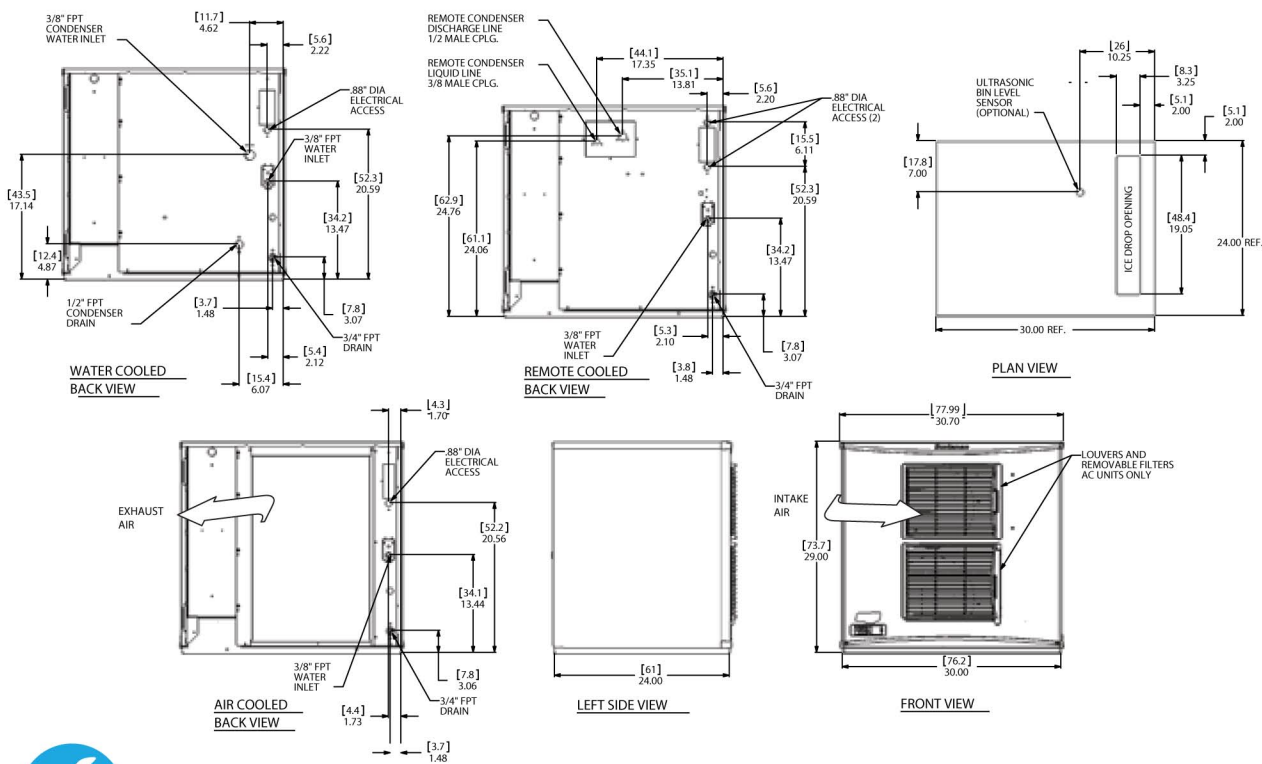

Specifications

Model Number	Condenser Unit	Basic Electrical Volts/Hz/Phase	Max. Fuse Size or HACR Circuit Breaker (amps)	Circuit Wires	Min. Circuit Ampacity	Energy Consumption kWh/100 lb (45.4 kg) 90°F(32°C)/70°F(21°C)	Water Usage Gallons/100 lb (liters/45.4 kg)		Energy Star®
							Potable 90°F(32°C)/70°F(21°C)	Condenser 90°F(32°C)/70°F(21°C)	
med. C0830MA-32	Air	208-230/60/1	15	2	10.2	5.3	21.6/81.8	-	☆☆☆
C0830MR-32	Remote	208-230/60/1	15	2	10.0	4.7	18.4/69.8	-	☆☆☆
sm. C0830SA-32	Air	208-230/60/1	15	2	10.2	5.3	21.6/81.8	-	☆☆☆
C0830SR-32	Remote	208-230/60/1	15	2	10.0	4.7	18.4/69.8	-	☆☆☆
C0830SW-32	Water	208-230/60/1	15	2	9.0	4.0	18.9/71.7	136.0/515.7	☆☆☆



All Models

Dimensions (W x D x H):

Unit: 30" x 24" x 29"
(76.2 x 61.0 x 73.7 cm)

Shipping Carton: 33.5" x 27.5" x 34"
(85.1 x 69.9 x 86.4 cm)

Shipping Weight: 220 lb / 100 kg
BTUs per hour: 13,700

Refrigerant: R-404A



Accessories

Model Number	Description
KVS	Vari-Smart™ Ice Level Control - Program ice bin levels to match ice needs.
KSBU	Smart-Board™ Advanced Control - Use additional operational data for fast diagnosis.
KSBU-N	Smart-Board™ Advanced Control with Network - Network capable.
ERC311-32	Remote condenser for C0830xR, 208-230/60/1 - Consult remote condenser spec sheet for details
RTE10	Line set, precharged, R-404A, 10ft.
RTE25	Line set, precharged, R-404A, 25ft.
RTE40	Line set, precharged, R-404A, 40ft.
RTE75	Line set, precharged, R-404A, 75ft.
KPAS	Prodigy Advanced Sustainability Kit - Includes KVS and KSBU - N

Scotsman recommends all ice machines have water filtration. See Scotsman water filter specification sheet for details.



Operating Requirements

	Minimum	Maximum
Air Temperatures	50°F (10°C)	100°F (38°C)
Water Temperatures	40°F (4.4°C)	100°F (38°C)
Remote Cond. Temps	-20°F (-29°C)	120°F (49°C)
Water Pressures	20 PSIG (1.4 bar)	80 PSIG (5.5 bar)
Electrical Voltage	-5%	+10%

Specifications and design are subject to change without notice.



C0830 - 800lb Cube Ice Machine