

AFE424 – 400 lb Flake Ice Machine

Self-Contained Undercounter Flaker with Storage



Features

- Improved design for higher reliability.
- Completely serviceable from the front side.
- Cabinet constructed of durable rust-free rotocast plastic.
- Delivers steady flow of ice for fast recovery of ice supply.
- 7 ft. power cord for quick installation.
- 3 piece cabinet is easily removable from the front.
- Front air flow allows for placement in tight spaces.

24 Hour Volume Production

Air Cooled			Water Cooled		
70°F/21°C 50°F/10°C lb/kg	Air Water	90°F/32°C 70°F/21°C lb/kg	70°F/21°C 50°F/10°C lb/kg	Air Water	90°F/32°C 70°F/21°C lb/kg
395/180		300/136	395/180		310/141



Slide away access door provides convenient and easy access to ice.

Flake Ice

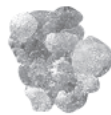

Cools more quickly than other ice forms. Used in produce and fish displays.

Warranty

- 2 years parts and labor on all components.
- 5 years parts on the compressor.

Warranty valid in North, South & Central America. Contact factory for warranty in other regions.

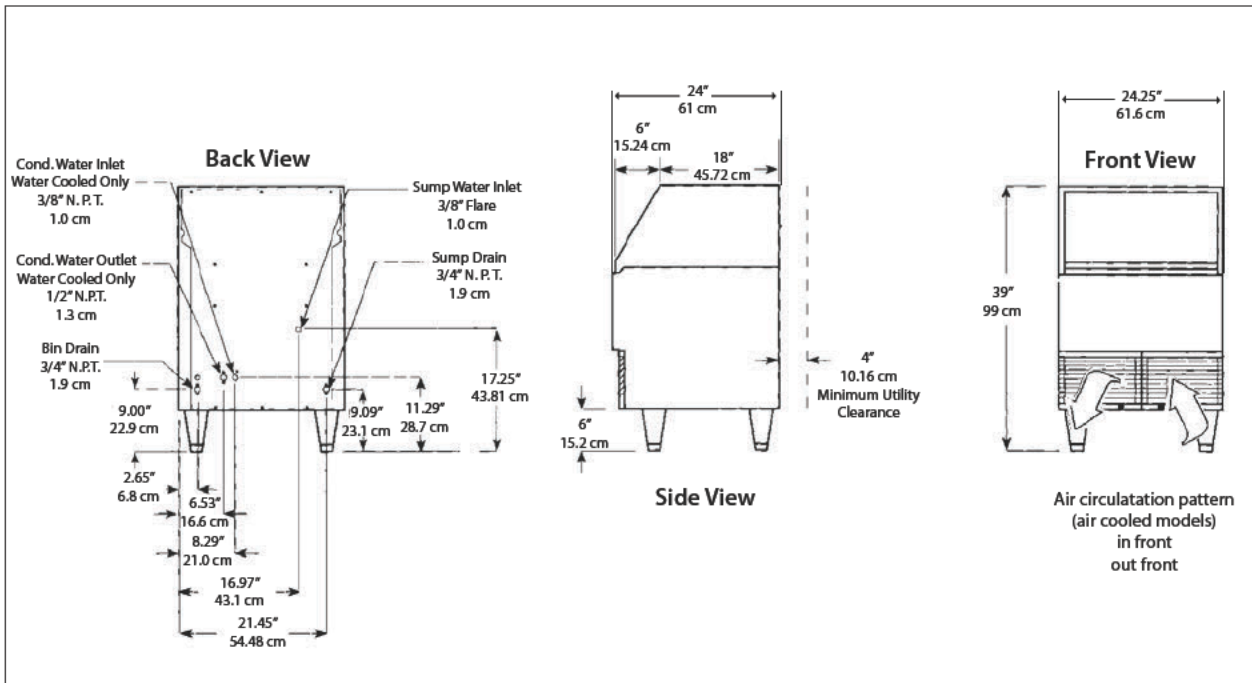

Specifications

Model Number	Condenser Unit	Storage lb/kg	Basic Electrical Volts/Hz/Phase	Max. Fuse Size or HACR Circuit Breaker (amps)	Circuit Wires	Min. Circuit Ampacity	Energy Consumption kWh/100 lb (45.4 kg) 90°F(32°C)/70°F(21°C)	Water Usage Gallons/100 lb (liters/45.4 kg)	
								Potable 90°F(32°C)/70°F(21°C)	Condenser 90°F(32°C)/70°F(21°C)
AFE424A-1A	Air	80/36	115/60/1	15	2	Cord	5.4	12.0/45.5	-
AFE424W-1A	Water	80/36	115/60/1	15	2	Cord	5.0	12.0/45.5	131.0/495.9

Refrigerant: R134A

All Models

Dimensions (W x D x H):
Unit: 24.25" x 24" x 33"
(61.6 x 61.0 x 83.8 cm)

Shipping Carton:
27" x 27.5" x 38"
(68.6 x 69.9 x 96.5 cm)

Shipping Weight:
185 lb/84 kg

BTUs per hour:
3,000

Accessories

Model Number	Description
KLP8S	Kit, Leg 6", Stainless Steel
KBC1	Kit, Casters

* Scotsman recommends all ice machines have water filtration. See Scotsman Sanitation Matrix for details.

Operating Requirements

	Minimum	Maximum
Air Temperatures	50°F (10°C)	100°F (38°C)
Water Temperatures	40°F (4.4°C)	100°F (38°C)
Water Pressures	20 PSIG (1.4 bar)	80 PSIG (5.5 bar)
Electrical Voltage	-5%	+10%

Specifications and design are subject to change without notice.

Scotsman Ice Systems
775 Corporate Woods Parkway
Vernon Hills, IL 60061

1-800-SCOTSMAN
Fax: 847-913-9844
E-mail: customer.service@scotsman-ice.com

www.scotsman-ice.com