

CU1526 / CU2026 - 150 lb / 200 lb Self-contained Ice Machine

Prodigy® Undercounter Cuber with Storage



CU1526 / CU2026

Features & Benefits

Prodigy® undercounter cubers use **significantly less energy and water** than other cube ice machines, exceeding California and Federal energy efficiency regulations.

Auto-Alert™ control panel can communicate operating status and signal when it's time to descale, sanitize, and more—making upkeep easier.

The patented **WaterSense adaptive purge control** delivers maximum reliability by reducing scale buildup for a longer time between cleanings.

All external panel components are crafted for **optimal aesthetic appeal** through superior fit and finish.

Preventative maintenance is simpler than ever with easily-removed door, top panel and storage bin allowing clear access to all internal components and a diagnostic code display insuring the right fix the first time.

Recessed front panel on/off switch and front removable air filter.

24 Hour Volume Production

Air Cooled		
70°F/21°C 50°F/10°C lb/kg	Air Water	ARI 90°F/32°C 70°F/21°C lb/kg
150/68		110/50
200/91		155/70

CU1526
CU2026

Water Cooled		
70°F/21°C 50°F/10°C lb/kg	Air Water	ARI 90°F/32°C 70°F/21°C lb/kg
175/80		124/56
240/109		190/83



Front Air Filter



Front On-Off
Switch

Cube Ice



Small Cube
3/8" x 3/8" x 3/8"
(2.22 x 2.22 x .95 cm)



Medium Cube
3/8" x 3/8" x 3/8"
(2.22 x 2.22 x 2.22 cm)

Common ice form, ideal for mixed drinks.

Warranty

- 3 years parts and labor on all components.
- 5 years parts and labor on the evaporator.
- 5 years parts on the compressor and condenser.

Warranty valid in North, South & Central America. Contact factory for warranty in other regions.

Scotsman®

The Smart Choice in Ice.™

CU1526 / CU2026 - 150 lb / 200 lb Self-contained Ice Machine

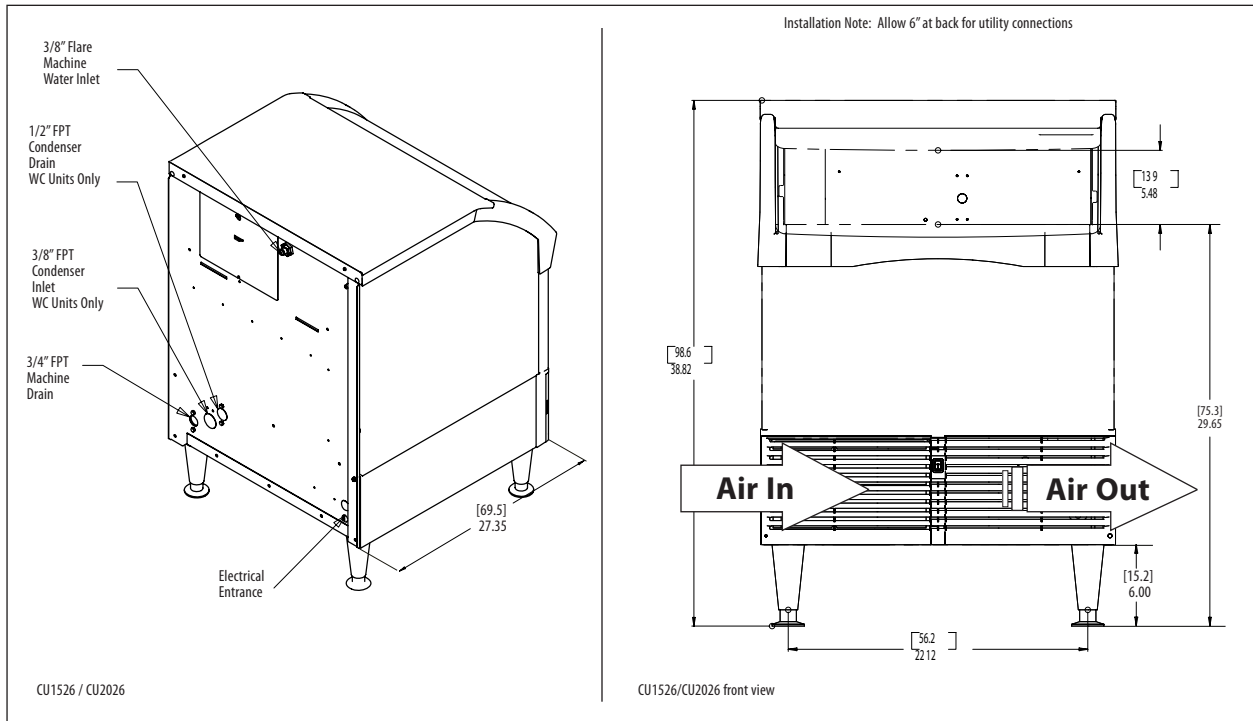

Specifications

Model Number* <small>Cube Size: medium or small</small>	Condenser Unit	Storage lb/kg	Basic Electrical Volts/Hz/Phase	Max. Fuse Size or HACR Circuit Breaker (amps)	Circuit Wires	Min. Circuit Ampacity	Energy Consumption kWh/100 lb (45.4 kg) 90°F(32°C)/70°F(21°C)	Water Usage Gallons/100 lb (liters/45 kg)	
								Potable 90°F(32°C)/70°F(21°C)	Condenser 90°F(32°C)/70°F(21°C)
CU1526MA-1A	Air	80/36	115/60/1	15	2	Cord	11.5	18.0/68.2	-
CU1526MW-1A	Water	80/36	115/60/1	15	2	Cord	8.8	18.0/68.2	160/606
CU1526SA-1A	Air	80/36	115/60/1	15	2	Cord	11.5	18.0/68.2	-
CU1526SW-1A	Water	80/36	115/60/1	15	2	Cord	8.8	18.0/68.2	160/606
CU2026MA-1A	Air	80/36	115/60/1	15	2	Cord	9.7	18.0/68.2	-
CU2026MW-1A	Water	80/36	115/60/1	15	2	Cord	6.6	18.0/68.2	180/682
CU2026SA-1A	Air	80/36	115/60/1	15	2	Cord	9.7	18.0/68.2	-
CU2026SW-1A	Water	80/36	115/60/1	15	2	Cord	6.6	18.0/68.2	180/682

* 208-230/60/1 Voltage - Substitute -32 in place of -1, i.e. CU2026SA-32A (CU2026 models only)

All Models

Dimensions (W x D x H):
 Unit: 26" x 27 3/8" x 33"
 (60.0 x 70.0 x 83.8 cm)

Shipping Weight:
 CU1526 - 150 lb / 68 kg
 CU2026 - 175 lb / 80 kg

Shipping Carton:
 29" x 30" x 37"
 (73.7 x 76.2 x 94.0 cm)

BTUs per hour:
 CU1526 - 3,100
 CU2026 - 3,900

Accessories

Model Number	Description
KLP8S	Kit 6 inch legs SS
KPUFM26	Kit Prodigy undercounter floor mount 26 inch for CU1526 - CU2026

* Scotsman recommends all ice machines have water filtration. See Scotsman Sanitation Matrix for details.

Operating Requirements

	Minimum	Maximum
Air Temperatures	50°F (10°C)	100°F (38°C)
Water Temperatures	40°F (4.4°C)	100°F (38°C)
Remote Cond. Temps	-20°F (-29°C)	120°F (49°C)
Water Pressures	20 PSIG (1.4 bar)	80 PSIG (5.5 bar)
Electrical Voltage	-10%	+10%

Specifications and design are subject to change without notice.

Scotsman Ice Systems
 775 Corporate Woods Parkway
 Vernon Hills, IL 60061

1-800-SCOTSMAN
 Fax: 847-913-9844
 E-mail: customer.service@scotsman-ice.com

www.scotsman-ice.com