

REFRIGERATOR MANUFACTURER
Turbo air
 more durable, efficient, beautiful

4184 E. Conant St.
 Long Beach, CA 90808
 Tel. 310-900-1000
 Fax. 310-900-1077
www.turboairinc.com

Project :	
Model # :	
Item # :	Qty :
Available W/H :	
Approval :	

Sandwich / Salad Unit

Food Prep Tables - Sandwich/Salad Prep
 Super Deluxe Series

Model : TST-48SD-N

Patented Self-Cleaning Condenser



This product is equipped with a fine mesh filter to the front of the condenser to catch dust, and a rotating brush that moves up and down daily to remove excess buildup outward and away.



≡ FEATURES & BENEFITS ≡

■ Self-Cleaning Condenser

The accumulation of dust in the condenser can cause the failure or breakdown of refrigerators. Refrigerators run normally until they reach a certain level of accumulation. At some point, when they are over the limit, their performance drops quickly resulting in damage to, or disposal of the stored products inside. The Self Cleaning Condenser device keeps the condenser clean and prevents system failure by automatically brushing daily.

■ Digital temperature control & monitor system

Keep food products safe by maintaining constant temperatures. External digital display allows for easy monitoring.

■ Hydrocarbon refrigerants (R-290)

With innovative and eco friendly technology, Turbo Air brings you hydro carbon refrigerators designed to meet the new standards of the EPA and DOE in 2017. Hydrocarbon refrigerants do not deplete the ozone layer and have very low contribution to global warming (ODP 0, GWP 3).

■ Cold Bunker system

Our innovative forced air system allows cold air to flow all around the food pan area, covering not only underneath the pan, but also the front, top and the rear. This unique air flow creates a cold air shield around the pan, which maintains the food temperature at under 41°F (NSF requirement) even when the lids are opened. In addition, the compartment isolates pans from the reach in area to prevent food spillage.

■ LED interior lighting

■ Stainless steel cabinet construction

The Turbo Air Super Deluxe model boasts a stainless steel interior (ABS door liner) and exterior (galvanized steel back & bottom). It guarantees the utmost in cleanliness and long product life. The Super Deluxe adds a touch of style to the most refined setting.

■ Sturdy, clean stainless steel shelving

Shelves are the most important part of cleanliness as they come in direct contact with food. After a while, PVC coated wire shelves may peel, rust and lead to unsanitary conditions. Only the Turbo Air Super Deluxe series uniquely provides stainless steel shelving.

■ High-density polyurethane insulation

The entire cabinet structure and solid doors are foamed in place high density, CFC free polyurethane insulation.

■ 9-1/2" deep, 1/2" thick high-density Polyethylene cutting board included with convenient side rail

■ Insulated pan cover

■ Refrigerator holds 33°F ~ 39°F for the best in food preservation

NATURAL Refrigerant

ISO9001:2008

Intertek

Intertek

5 YEAR WARRANTY

5 YEAR WARRANTY

Model	Swing Door	CU./FT.	#of Shelves	#of Pans	HP	AMPS	Crated Weight (lbs.)	L x D x H† (inches)
TST-48SD-N	2	12	2	12	1/5	4.4	273	48 1/4 x 30 x 37

Sandwich / Salad Unit

Food Prep Tables - Sandwich/Salad Prep
Super Deluxe Series

Model : TST-48SD-N

ELECTRICAL DATA	
Voltage	115/60/1
Plug Type	Ⓜ NEMA 5-15P
Full Load Amperes	4.4
Compressor HP	1/5
Feed Wires with Ground	3
Cord Length (ft.)	9
Refrigerant	R-290
DIMENSIONAL DATA	
Ext. Length Overall (in.)	48 1/4 (1226mm)
Ext. Depth Overall (in.) *	30 (762mm)
Ext. Height Overall (in.) †	37 (940mm)
# of Doors	2
# of Shelves	2
# of Pans	12
# of Hood	1
Net Capacity (cu. ft.)	12
Net Weight (lbs.)	243
Gross Weight (lbs.)	273
Shelf Size (in.)	21 x 17

Design and specifications subject to change without notice.
Actual shipping weight may differ due to extra packing materials for product protection.
* Depth does not include 1" for rear spacers.
† Height does not include 5" for caster height.

- **WARRANTY :** 3 Year Parts and Labor Warranty
Additional 2 Year Warranty on Compressor
- **Anti-corrosion coated evaporator**
- **Self-contained system**
- **Standard 4" dia. swivel casters with locks on the front set**
- **Standard 1/6 size, 4" deep condiment pans included**
- **2.5" dia. casters available (optional) & Legs available (optional)**
- **Removable food covers available (optional)**
- **Stainless steel double overshef available (optional)**
- **OPTIONAL ACCESSORIES :**
 - 2.5" caster, 1/2" diameter & 13 TPI: 30265H0100 (non brake), 30265H0200 (w/ brake)
 - 5" caster, 1/2" diameter & 13 TPI: M726500100 (non brake), M726500200 (w/ brake)
 - 6" ABS plastic leg: 30221M0200
 - 6" stainless steel leg: 30221M0600
 - Additional stainless steel shelf: M727800100
 - Removable food cover: RCT 48
 - Stainless steel double overshef: TSOS 4R
 - Door lock: extra lead time will apply, please call factory for more details to order**

Ver.20171009

PLAN VIEW

(unit : inch)

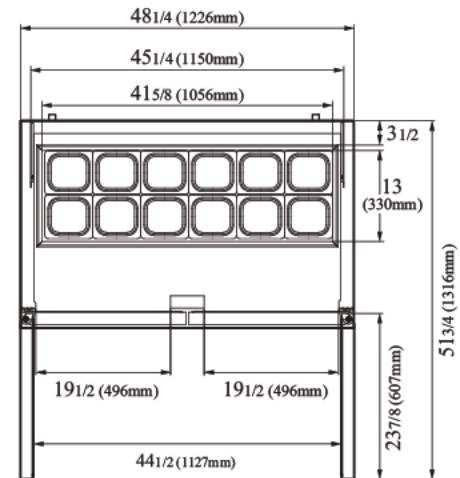

PLAN VIEW

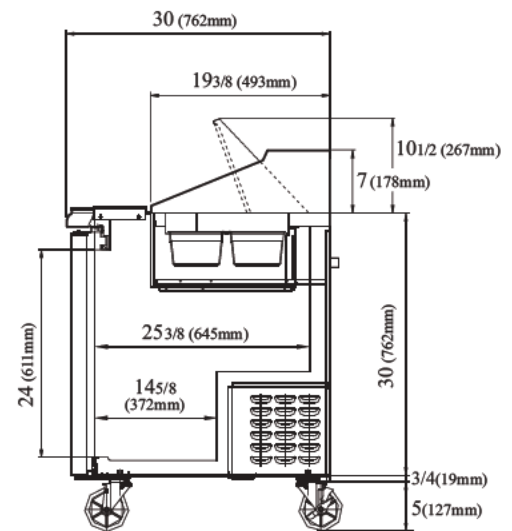

SIDE VIEW



- Turbo Air : 800 627 0032 ■ GK : 800 500 3519
- Warranty : 800 381 7770 ■ AC : 888 900 1002

