



Project:

Item Number:

Quantity:

### HOT FOOD MERCHANDISERS



Hot Food Merchandiser

#### DESCRIPTION

Vollrath® Hot Food Merchandisers are the ideal solution for presenting and keeping a variety of foods warm. Variable heat control with humidity keeps food at the right temperature, while three adjustable shelves accommodate and attractively merchandise your products. Front and rear sliding lockable doors make restocking easy and are ideal for self-serve operations.

#### ITEMS

Item	Model	Description
HFM-26	FMA7026	Hot Food Merchandiser - 26"
HFM-36	FMA7036	Hot Food Merchandiser - 36"
HFM-48	FMA7048	Hot Food Merchandiser - 48"

#### FEATURES & BENEFITS

- Thermostatically-controlled heat with 95 ° to 200 ° F (35 ° to 93 °C) range maintains user settings to ensure consistent temperature.
- Specially-designed baffle provides even heating.
- Centrally-located water pan humidifies food to keep products looking fresh longer.
- Front and rear sliding, lockable doors are convenient for loading and customer self-service.
- Three adjustable shelves offer versatile display options.
- Illuminated display attracts customers.
- Door Lock and One-Piece Front Glass accessories are available separately for additional security.
- LED lighting can be used when heat is on or off.
- 5 ft. (1.5 m) cord and plug allow placement options.

#### AGENCY LISTINGS



Due to continued product improvement, please consult [vollrathfoodservice.com](http://vollrathfoodservice.com) for current product specifications.

#### WARRANTY

All models shown come with Vollrath's 1-year standard warranty against defects in materials and workmanship. For full warranty details, please refer to [vollrathfoodservice.com](http://vollrathfoodservice.com).

Approvals	Date

## DIMENSIONS

Shown in inches (cm)

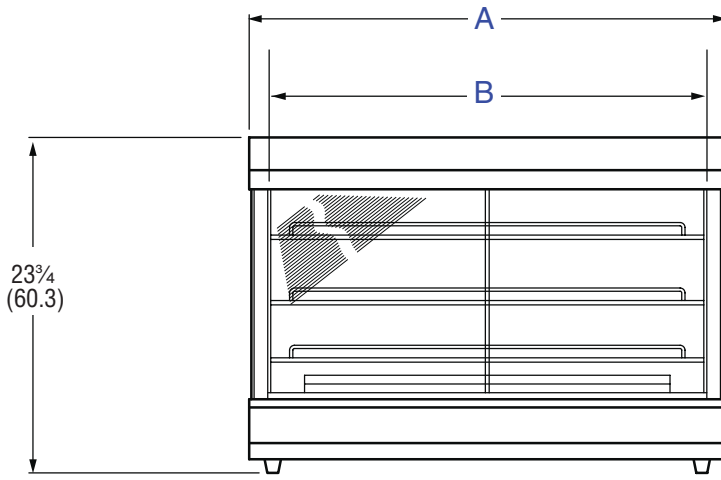

Front View

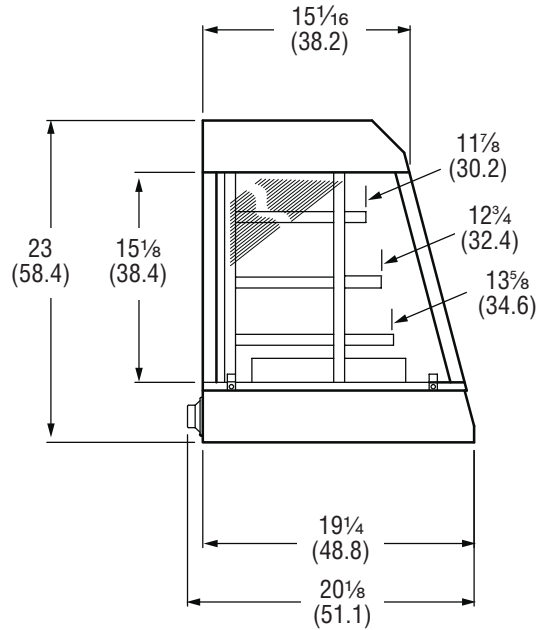

Side View

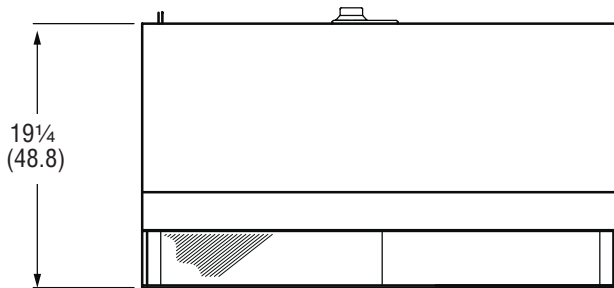

Top View

## SPECIFICATIONS

Item	Description	(A) Overall Width	(B) Overall Width	Voltage	Watts	Amps	Shipping Weight LB (KG)	Plug	Receptacles
HFM-26	Hot Food Merchandiser - 26"	26 (66)	22 <sup>3</sup> / <sub>4</sub> (57.8)	120 AC	1440	12	85 (38.6)	NEMA 5-15P	120V  NEMA 5-15R
HFM-36	Hot Food Merchandiser - 36"	36 (91.4)	32 <sup>1</sup> / <sub>4</sub> (81.9)				108 (49)		
HFM-48	Hot Food Merchandiser - 48"	48 (119.4)	44 <sup>1</sup> / <sub>4</sub> (112.4)				139 (63)		



**The Vollrath Company, L.L.C.**  
 1236 North 18th Street  
 Sheboygan, WI 53081-3201 U.S.A.  
 Main Tel: 800.624.2051 or 920.457.4851  
 Main Fax: 800.752.5620 or 920.459.6573  
 Customer Service: 800.628.0830  
 Canada Customer Service: 800.695.8560

Technical Services  
 techservicereps@vollrathco.com  
 Induction Products: 800.825.6036  
 Countertop Warming Products: 800.354.1970  
 All Other Products: 800.628.0832