

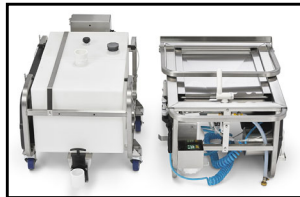

Project:
Item Number:
Quantity:

COMPANION CART - MOBILE CLEANING AND SANITIZING SYSTEM



DESCRIPTION

Stoelting's Mobile Cleaning, Sanitizing and Disinfecting System allows you and your team the convenience of mobile disinfecting, sanitizing and cleaning in one easy to transport cart. It is easy to move; set on casters to quickly move from place-to-place. It is easy to disassemble and transport, allowing you to pack up and go when needed. The system saves time and money by providing the tools you need, to both clean and sanitize your equipment, in one mobile cart. The recommended sanitizing solution is certified hospital-grade disinfectant and ready to clean all of your surfaces.

Ideal for locations such as:

- Healthcare, Mobile Hospitals, Medical Labs
- Cafeterias
- Convenience Stores
- Military Sites
- Corrections Facilities
- Senior Living
- Supermarkets
- Retail Warehouse Clubs
- Manufacturing Facilities
- Marine Facilities

WARRANTY

For full warranty details, please see www.stoeltingfoodservice.com

AGENCY LISTINGS



Due to continued product improvement, please consult www.vollrath.com for current product specifications.

ITEMS

Item No.	Description
CIPCART-1	Direct Connect to Water Supply
CIPCART-2	Self-Contained with Pump

FEATURES

CIPCART-1

- Modular design for easy disassemble, transport and reassemble.
- Does not require an electrical connection. The faucet runs off of water pressure from the hose.
- The hose connects directly and easily to the water supply (CIPCART-1 only).
- Fifty foot hose is safe for potable water.
- On-board 15-gallon gray water tank means fewer trips to empty the tank, saving time and labor.
- Spray wand with adjustable flow rate creates an easier and more efficient sanitizing process.
- Built-in holders for hose, paper towel, and sanitizing wipes (included) improve efficiency.
- Extendable drain board provides additional counter space.
- Caster wheels, two lock.

CIPCART-2

All of the features of the CIPCART-1 system plus the following:

- Self-contained operation.
- On-board 15-gallon freshwater and 15-gallon gray water tanks enable use of the cart without an external water connection.
- The 12V SLA battery-powered water pump provides up to three hours of regular use.
- Integrated Hydra Rinse™ sanitizing and washing system includes a spray wand with coiled hose that connects to LEXX™ liquid sanitizer and cleaner concentrate (included).
- Dial controls enable the user to switch between water or LEXX™ delivery, creating full sanitizing capabilities.
- Recommended sanitizing products are environmentally friendly and EPA certified as a hospital grade disinfectant when used with a disinfecting wand (sold separately).
- Recommended product can also meet FDA requirements for medical devices. Please consult the sanitizing solution documentation for instructions.
- Pump battery recharges in approximately two hours.
- Foldable faucet for easy storage.
- Folding step stool, rated for 250 lbs., conveniently stows on cart.
- 6 ft. (183 cm) battery charger cord.

ACCESSORIES AND OPTIONS

- 265002** Hydra Rinse™ All-Purpose Wipes
- 265003** LEXX™ Liquid Sanitizer and Cleaner Concentrate (1 Gal)

Approvals	Date



The Vollrath Company, L.L.C.
 1236 North 18th Street
 Sheboygan, WI 53081-3201 U.S.A.
 Main Tel: 800.624.2051 or 920.457.4851
 Main Fax: 800.752.5620 or 920.459.6573
 Customer Service: 800.628.0830
 Canada Customer Service: 800.695.8560

Technical Service Information



Every machine includes White Glove Service. One call does it all – customer service, technical service, parts or warranty information, installation, startup, sales, on-site service dispatch and much more. Available 24 hours a day, seven days a week year-round.

800-319-9549 (U.S. Toll Free)
 920-894-2293 (Outside the U.S.)

COMPANION CART - MOBILE CLEANING AND SANITIZING SYSTEM

DIMENSIONS (Shown in inches)

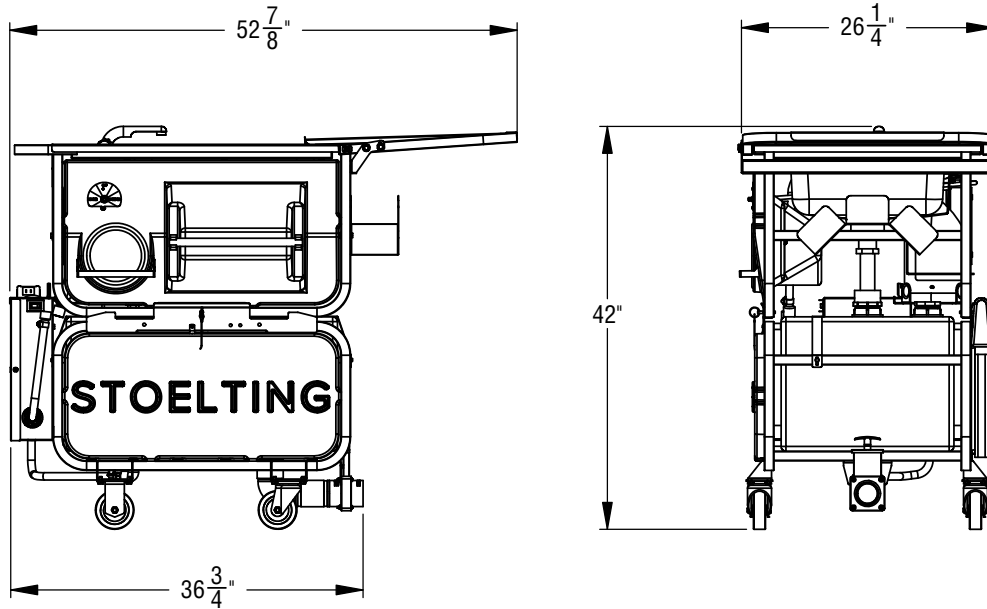

SPECIFICATIONS

Item No.	Fresh Water Tank (gallons)	Waste Water Tank (gallons)	Waste Water Outlet	Volts	Amps	Weight* lb (kg)	Crated Weight* lb (kg)	Plug
CIPCART-1	N/A	15	2" N.P.T.	N/A	N/A	114 (51.7)	150 (68.0)	N/A
CIPCART-2	15	15	2" N.P.T.	120V	0.3	136 (61.7)	172 (78.0)	NEMA 5-15P

Receptacle

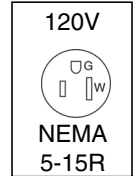

* Weight is with empty water tanks.

UPGRADE KITS

The Portable Cleaning Systems can be customized for your specific needs.

Upgrade Kit	CIPCART-1	CIPCART-2
Fresh water tank – 15 gallons	Upgrade	Standard
Foldable faucet for easy storage		
Water pump system (includes pump, battery, and charger)		
Folding step stool (includes mounting bracket)		
Hydra Rinse™ wand system		



vollrathfoodservice.com

The Vollrath Company, L.L.C.
 1236 North 18th Street
 Sheboygan, WI 53081-3201 U.S.A.
 Main Tel: 800.624.2051 or 920.457.4851
 Main Fax: 800.752.5620 or 920.459.6573
 Customer Service: 800.628.0830
 Canada Customer Service: 800.695.8560

Technical Service Information



Every machine includes White Glove Service. One call does it all – customer service, technical service, parts or warranty information, installation, startup, sales, on-site service dispatch and much more. Available 24 hours a day, seven days a week year-round.
 800-319-9549 (U.S. Toll Free)
 920-894-2293 (Outside the U.S.)