

FLEXIBLE ARM CARVING STATIONS IFW-61-GL SERIES

FEATURES AND BENEFITS:

- Portable adjustable infra red warmer with maple cutting board.
- Flexible arm's tension keeps lamp in position once adjusted.
- Supplied with shatter resistant and thermal shock resistant 250 Watt red lamp (120 Volts). White lamp available upon request.
- On-Off switch mounted on base for convenience.
- Hood available in Polished Brass or Polished Nickel.



IFW-61-GL-10PB



ACCESSORIES and OPTIONS (Available at extra cost):

- Resilient Cutting Board
- Drip Pan
- Carving Stand Kit
- Shatter Proof Lamp
- 240 Volt Service

See page I-13 for accessory details.

IFW-61-GL Series

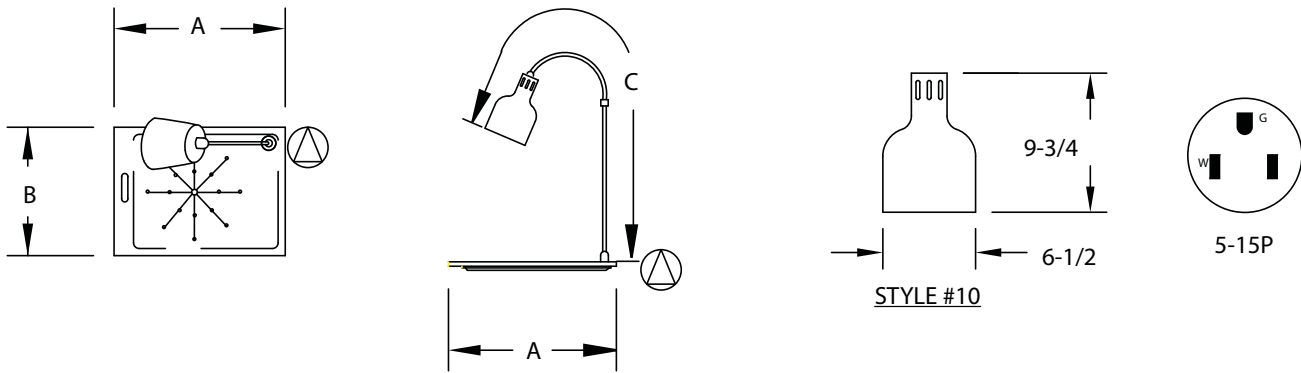

CRES COR MODEL NO.	DIM "A" WIDTH		DIM "B" DEPTH		DIM "C" HEIGHT		WEIGHT ACT.	
	INCHES	MM	INCHES	MM	INCHES	MM	LBS.	KG.
IFW-61-GL-10PB	24	610	16	410	52	1325	31	14
IFW-61-GL-10PN	24	610	16	410	52	1325	31	14

WARMER:

- Hood: Spun from .051 aluminum.
IFW-61-GL-10PB: Polished Brass Powder Coat.
IFW-61-GL-10PN: Polished Nickel Powder Coat
- Flexible tube: .585 O.D., nickel chrome plated and clear vinyl powder coated.
- Rigid tube: 5/8 O.D. x 15", nickel chrome plated steel.
- Base: Cast zinc, nickel chrome plated; rigid tube screws into base.
- Bolts to cutting board.

CUTTING BOARD

- Maple block wood, 16 x 24 x 1-3/4.

ELECTRICAL COMPONENTS:

- Toggle switch: Mounted on base.
- Power cord: 6ft., 14/3 ga. with molded plug.
- Socket: Porcelain.
- Lamp: 250 Watts, red.

POWER REQUIREMENTS:

- 250 Watts, 120 Volts, 60 Hz., single phase, 2 Amps., 15 Amp. service.

SHORT FORM SPECIFICATIONS

Cres Cor Carving Station Model IFW-61-GL-_____.
Hood .051 spun aluminum; Powder Coat finish
(color: _____). Rigid stem and flexible arm nickel
chrome plated. Cast zinc nickel chrome plated base.
Maple cutting board. 250 Watts, 120 Volts, 60 Hz.,
1 Phase, 15 Amp. service. 2 year parts warranty.
Provide the following accessories: _____.
NSF listed.



5925 Heisley Road • Mentor, OH 44060-1833
Phone: 877/CRESCOR • Fax: 440/350-7267
www.crescor.com

© Crescent Metal Products, Inc. 2008 All rights reserved.

*In line with its policy to continually improve its products,
CRES COR reserves the right to change materials and
specifications without notice.*

Litho in U.S.A.