



Outperform every day.™

Project:
Item Number:
Quantity:

Vacuum Pack Machine with Dual 16" Sealing Bars and Advanced Control System The Vollrath Company, L.L.C.

VACUUM PACK MACHINE WITH DUAL 16" SEALING BARS AND ADVANCED CONTROL SYSTEM



DESCRIPTION

Vollrath's vacuum pack machines extend the life of fresh and frozen foods and are ideal for vacuum packing for sous vide cooking.

The Vacuum Pack Machine with Dual 16" Sealing Bars and Advanced Control System machine has as all the features of the VP16 model, plus a digital control system that offers additional features and convenience.

Note, this machine is not designed for continuous use. Allow a 15 second rest between packing cycles for best performance. Intended for a maximum use of five hours per day.

ITEMS

Item No.	Model No.	Description
40834	VPP16	Vacuum Pack Machine with Dual 16" Seal Bars and Advanced Control System

FEATURES

- Busch rotary vacuum pump
- Stainless steel exterior
- Deep drawn stainless steel vacuum chamber with round corners
- Transparent, soft-open lid for monitoring functions
- Dual sealing bars accommodate multiple bags up to 16" (40.6 cm) wide
- Double seals for extra secure bags
- Sealing bars easily remove without tools for cleaning and maintenance
- Includes three insert plates for packing small products
- Includes incline plate for packing liquids and fine powders
- Maximum vacuum is 99.8% (2 m bar)
- Set vacuum function by sensor control (% pressure)
- Advanced Control System features password controlled access; 20 programs with Liquid Control, Soft-Air, Vacuum Plus, Tenderize and label printing functions; and HACCP compliant logging.
- Liquid Control detects the boiling point, stops the vacuum and advances to the next step to reduce cycle time, produce a better quality product and save the pump from taking on liquids
- Vacuum Plus enables air trapped within a product to escape
- Soft-Air reduces damage to delicate foods or the bag
- Compatible with Zebra® LP/TLP 2824 Plus™ label printers
- Pump Conditioning program removes moisture and debris from pump
- Two sealing cylinders provide optimal pressure to deliver high-quality seals
- Maintenance reminder
- Included 4" (10.2 cm) legs required for ETL Sanitation
- Includes maintenance kit with oil, lid gasket, silicone bar, Teflon® tape and sealing wire
- 6 ft. (182.9 cm) cord with plug

WARRANTY

All models shown come with Vollrath's standard warranty against defects in materials and workmanship. One year on the pump and two years on other warranty parts. For full warranty details, please refer to www.Vollrath.com.

CLEARANCE AND ENVIRONMENT REQUIREMENTS

Requires 6" (15 cm) clearance on all sides and 15½" (39.4 cm) above the machine.

Approvals	Date

Agency Listings



Due to continued product improvement, please consult www.vollrath.com for current product specifications.



Outperform every day.™

www.vollrath.com

The Vollrath Company, L.L.C.

1236 North 18th Street
Sheboygan, WI 53081-3201 U.S.A.
Main Tel: 800.624.2051 or 920.457.4851
Main Fax: 800.752.5620 or 920.459.6573
Customer Service: 800.628.0830
Canada Customer Service: 800.695.8560

Technical Services
techservicereps@vollrathco.com
Induction Products: 800.825.6036
Countertop Warming Products: 800.354.1970
All Other Products: 800.628.0832

VACUUM PACK MACHINE WITH DUAL 16" SEALING BARS AND ADVANCED CONTROL SYSTEM

DIMENSIONS (Shown in inches (cm))

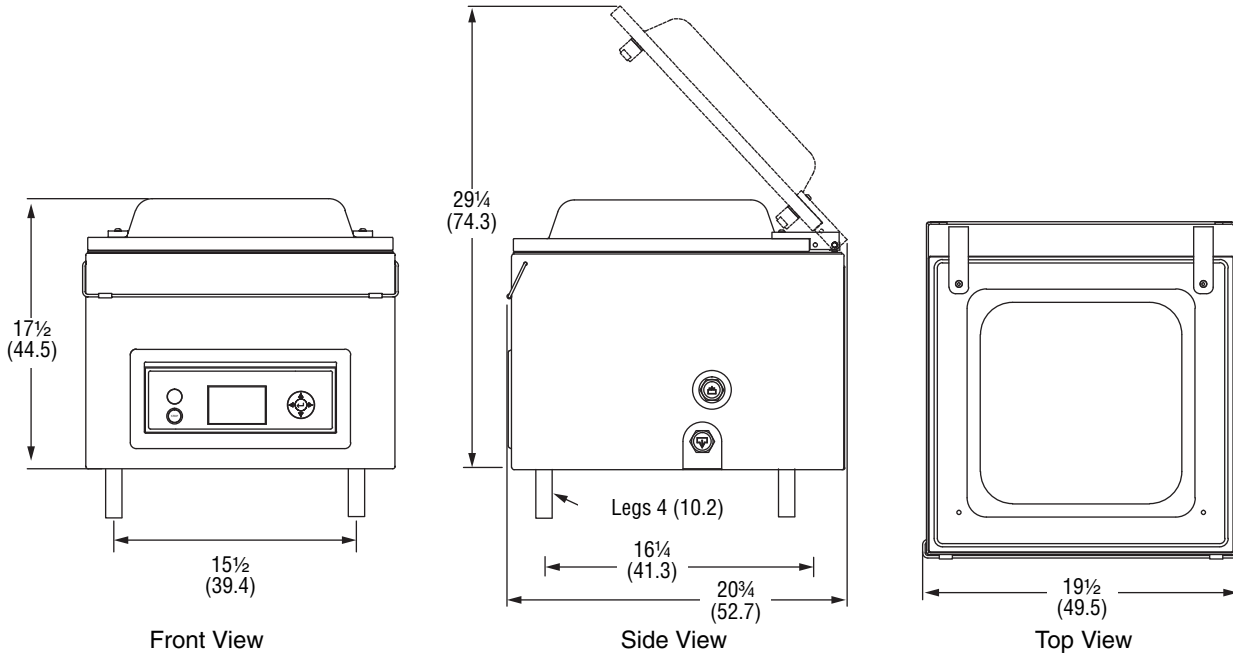

SPECIFICATIONS

Item No.	Dimensions IN (CM)		Volts	Amps	Hz	Pump Capacity m3/hr	HP	Plug	Weight LB (KG)
	Chamber (W x D x H)	Maximum Product Height							
40834	16 ¹³ / ₁₆ x 16½ x 5 (42.7 x 41.9 x 12.7)	7½ (19.1)	120	13	60	25	1.3	NEMA 5-20P	136.7 (62)

Receptacle

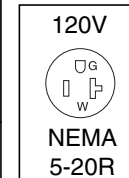

Outperform every day.™

www.vollrath.com

The Vollrath Company, L.L.C.

1236 North 18th Street
Sheboygan, WI 53081-3201 U.S.A.
Main Tel: 800.624.2051 or 920.457.4851
Main Fax: 800.752.5620 or 920.459.6573
Customer Service: 800.628.0830
Canada Customer Service: 800.695.8560

Technical Services
techservicereps@vollrathco.com
Induction Products: 800.825.6036
Countertop Warming Products: 800.354.1970
All Other Products: 800.628.0832