

Conserver[®] XL-E

Project _____
 Item _____
 Quantity _____
 CSI Section 11400
 Approval _____
 Date _____

Conserver[®] XL-E

Models

Conserver[®] XL-E



Standard Features

- Electromechanical timer
- Internal sump design
- Built-in waste accumulator
- Delimer switch for easy removal of hard water deposits
- Removable scrap screen
- Air gap instead of vacuum breaker
- Door switch
- Convenient top mounted controls
- Auto start
- Interchangeable upper and lower stainless steel wash/rinse arms
- Wash thermometer
- Low chemical indicator lights
- Stainless steel adjustable bullet feet

Mandatory Specs

Specify voltage _____

Options

- Water Hammer Arrestor
- Scaltrol
- False Panel
- Flanged Feet
- Audible Low Product Alarm
(available only on 115v models)

Accessories

- 36-Compartment Rack
 - 4-1/8" tall (105 mm)
 - 5-5/8" tall (143 mm)
 - 7" tall (178 mm)
- Combination Rack
- Peg Rack

Specifications

Uses 1.02 gallons (3.9 liters) water per rack

39 racks per hour (Normal cycle)

Single point electrical connection

Self-draining stainless steel pump eliminates soil/detergent carryover between wash and rinse cycles

Fill and Dump design disposes of dirty water, replacing it with a fresh water rinse every cycle

Field convertible from straight to corner and corner to straight for flexible installations and applications

17-1/4" (438 mm) vertical inside clearance

Built-in chemical pumps and priming switches

Large removable scrap screen

Durable stainless steel construction



Intertek



Intertek



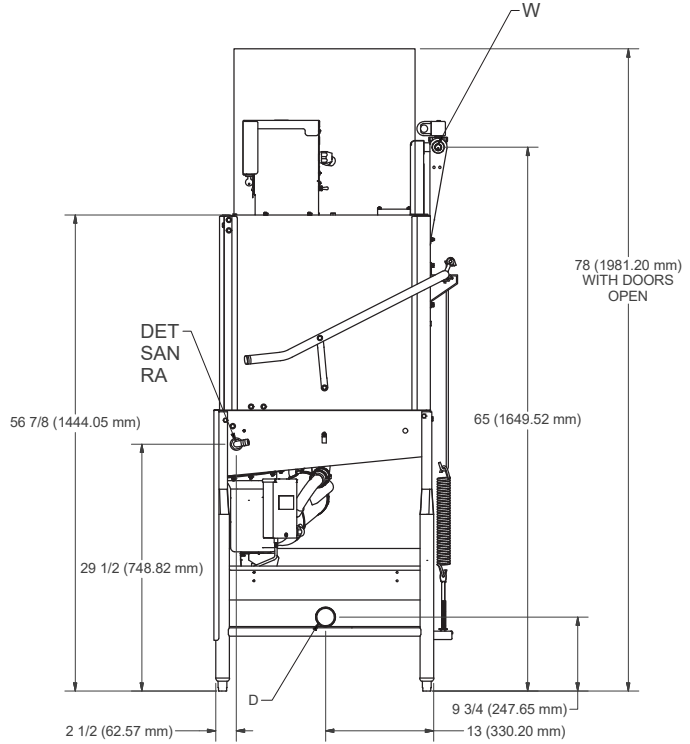
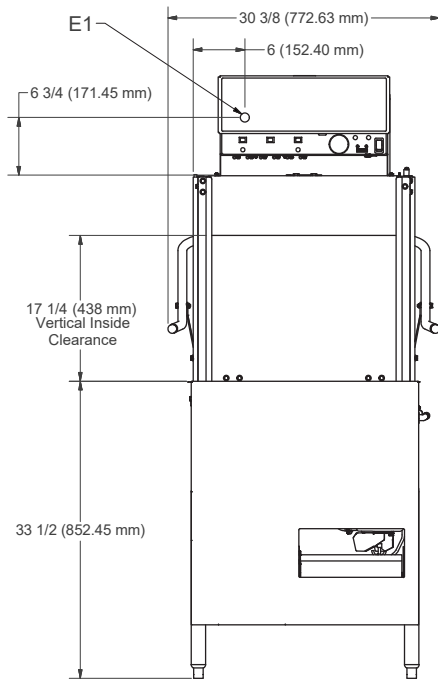

**TABLE DIMENSIONS
CONNECTION TO DISHMACHINE**

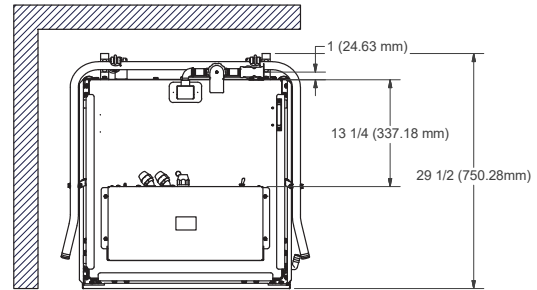
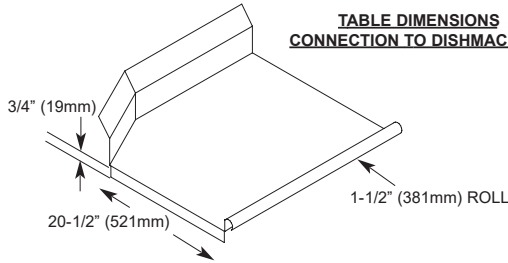

- Legend:**
 E1: Main Electrical Connection (1-1/8" DIA Hole)
 W: Main Inlet Water Connection (3/4" NPT - Female)
 D: Drain Connection (2" NPT - Male)
 DET: Detergent Bulkhead Access (5/8" DIA Hole)
 SAN: Sanitizer Inlet
 RA: Rinse Aid Inlet

All dimensions from the floor can be increased 1.5" using the machine's adjustable feet

MODEL NO.	MACHINE DIMENSIONS					DRAIN HEIGHT	SHIPPING INFORMATION				
	HEIGHT	WIDTH	WIDTH BETWEEN DISHTABLES	DEPTH	DEPTH		WEIGHT	CLASS	CUBE	HEIGHT	WIDTH
Conserv ^{er} ® XL-E	68-1/2" (1740 mm)	30-3/8" (772 mm)	25-1/4" (641 mm)	29-1/2" (749 mm)	9-3/4" (248 mm)	230 lbs (105 kg)	300	58.15 cu. ft.	72.5" (1842 mm)	33" (838 mm)	42" (1067 mm)

APPROXIMATE AMP LOADS

115V/60HZ/1PH	11.4 AMPS
230V/60HZ/1PH	6.6 AMPS

WATER REQUIREMENTS

	MINIMUM	RECOMMENDED
Inlet Temperature	120°F (49 °C)	140°F (60 °C)
Wash Operating Temperature	120°F (49 °C)	140°F (60 °C)
Rinse Operating Temperature	120°F (49 °C)	140°F (60 °C)

PERFORMANCE CAPABILITIES

Flow Pressure (PSI)	20 ±5
Wash Pump Motor Horsepower	1
Pump Capacity (GPM)	55
Minimum Chlorine Required (PPM)	50

HOW TO SPECIFY: Conserv^{er}® XL-E

Jackson WWS, Inc.

Shipping Address: 6209 North U.S. Highway 25E, Gray, KY 40734
 Mailing Address: P.O.Box 1060, Barbourville, KY 40906
 Telephone: 888-800-5672 • Fax: 606-523-1799
 Email: info@jacksonwws.com
 07610-004-00-91 [12/14/17]

www.jacksonwws.com