



BEVERAGE-AIR

Project: _____

AIA#

Item: _____

Location: _____

SIS#

Approved: _____

VISTA® BOTTOM MOUNT REACH-IN FREEZER

MODEL:

FB35HC Glass Door Reach-in Freezer

FB35HC-1G

Hydrocarbon Series



3 Year Parts/Labor Warranty
Additional 4 Year Compressor Warranty

CABINET CONSTRUCTION

- Stainless steel front and doors, gray painted sides
- Gray painted aluminum interior
- Full electronic control
- LED lighting
- Self-closing door with 120° stay-open feature, on spring-loaded hinges
- One-piece grille allows easy removal/installation for preventative maintenance
- Three (3) heavy duty epoxy coated wire shelves standard
- 6" Casters with (2) brakes

OPTIONS & ACCESSORIES

- Additional epoxy shelves (5 maximum per section)
- Shelf clips
- 3" Casters or 6" legs
- 6" Flanged/seismic feet
- Door locks
- Remote option* (see note on back page)

REFRIGERATION SYSTEM

- Uses environmentally friendly, energy efficient R290 refrigerant, and meets all regulatory requirements for CARB, SNAP, DOE & more
- Hot gas condensate evaporation
- Adaptive defrost
- Epoxy coated evaporator coil
- Freezer capable of maintaining product temperature down to -10°F

FB35HC BOTTOM MOUNT MODEL: VISTA® SERIES



Please verify qualifying units by visiting:
www.energystar.gov/cfs

3779 Champion Blvd., Winston-Salem, NC 27105

1-888-845-9800 Fax: 1-336-245-6453

Beverage-Air.com Sales@bevair.com



BEVERAGE-AIR

MODEL	FB35HC-1G
EXTERNAL DIMENSIONAL DATA	
Width Overall	39 1/2"
Depth Overall with Handle	33 5/8"
Height Overall	84"
Number of Doors	2
Depth with Door Open 90°	49 5/8"
Door Opening	16 1/2" x 52 5/8"
INTERNAL DIMENSIONAL DATA	
NET Capacity (cubic ft.)	36.87
Internal Width Overall (in)	36 3/8"
Internal Depth Overall (in)	25 7/8"
Internal Height Overall (in)	61 7/8"
Internal Height Useable (in)	52 7/8"
Number of Shelves	6
ELECTRICAL DATA	
Full Load Amperes 115/60/1	11.0
REFRIGERATION DATA	
Horsepower	3/4
Capacity (BTU/Hr)*	2312
SHIPPING DATA	
Gross Weight - Crated	456 lbs
Height - Crated	85"
Width - Crated	56"
Depth - Crated	36"

*NOTE: Remote units are field wired and come with 6" legs. Refrigerant must be specified at time of order.

Bottom Mount Reach-in Freezer

Model: FB35HC-1G

Model Views

Required clearance: 3" bottom and back

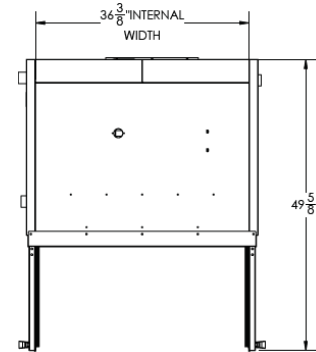

Plan View

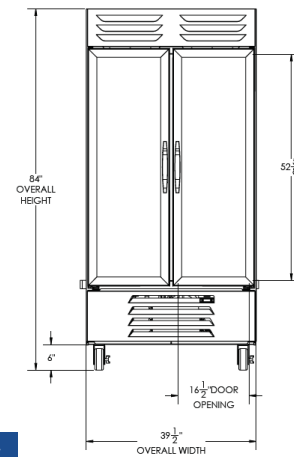

Elevation View

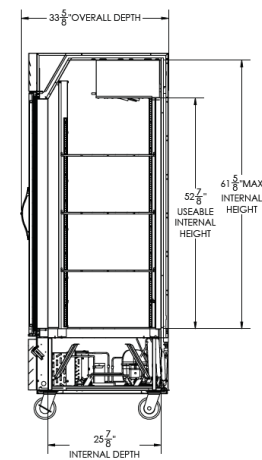

Side View

ELECTRICAL CONNECTION



115/60/1
NEMA-5-15P

Unit pre-wired at factory and include 8' long cord and plug set.



3779 Champion Blvd., Winston-Salem, NC 27105 1-888-845-9800 Fax: 1-336-245-6453 Beverage-Air.com Sales@bevair.com

an Ali Group Company



The Spirit of Excellence