



BEVERAGE-AIR

Project: _____

AIA#

Item: _____

Location: _____

SIS#

Approved: _____

BB BAR EQUIPMENT - BACK BAR REFRIGERATOR

BB72HC Sliding Glass Door / Food Rated / Stainless Steel Top
Hydrocarbon Series

MODEL:

BB72HC-1-F-GS-B-27

BB72HC-1-F-GS-S-27

BB72HC Back Bar Refrigerators: Sliding Door Series

3 Year Parts/Labor Warranty
Additional 2 Year Compressor Warranty

CABINET CONSTRUCTION



BB72HC-1-F-GS-S-27

- Exterior black or stainless steel
- Stainless steel interior
- Full electronic control
- 2" Stainless steel top
- Two (2) epoxy coated shelves per section, standard
- Self-closing sliding glass doors have black frame regardless of finish
- Stay-open feature
- LED lighting
- Certified for open food product
- Compressor available on left or right, specify at time of unit order
- Balanced, forced air refrigeration system provides rapid chilling of product
- Maintains product temperature between 36°F and 38°F

OPTIONS & ACCESSORIES

- Wine model (40°-60° models)
- Wine shelf divider
- Pass-thru models available
- 3" or 6" casters
- Glass or solid doors
- Remote option

REFRIGERATION SYSTEM

- Refrigeration system uses R290 refrigerant to comply with all environmental concerns
- Automatic, non-electric defrost
- Epoxy coated evaporator coil



3779 Champion Blvd., Winston-Salem, NC 27105
1-888-845-9800 Fax: 1-336-245-6453
Beverage-Air.com sales@bevair.com



BEVERAGE-AIR

Bar Equipment-Sliding Glass Door Food Rated with Stainless Steel Top Model: BB72HC-1-F-GS-B-27, BB72HC-1-F-GS-S-27

MODEL	BB72HC-1-F-GS-B-27	BB72HC-1-F-GS-S-27
EXTERNAL DIMENSIONAL DATA		
Width Overall	72"	72"
Depth Overall	23 5/8"	23 5/8"
Height Overall	36"	36"
Number of Doors	3	3
Door Opening (in)	-	-
INTERNAL DIMENSIONAL DATA		
NET Capacity (cubic ft.)	19.92	19.92
Internal Width Overall (in)	60 1/4"	60 1/4"
Internal Depth Overall (in)	18 1/2"	18 1/2"
Internal Height Overall (in)	28"	28"
Number of Shelves	6	6
Number of Kegs	3	3
ELECTRICAL DATA		
Full Load Amperes 115/60/1	3.1	3.1
REFRIGERATION DATA		
Horsepower	1/3	1/3
Capacity (BTU/Hr)*	1942	1942
WEIGHT DATA		
Gross Weight (Crated lbs)	392 lbs	375 lbs
Height - Crated	43"	43"
Width - Crated	74"	75"
Depth - Crated	27"	27"

Model Views

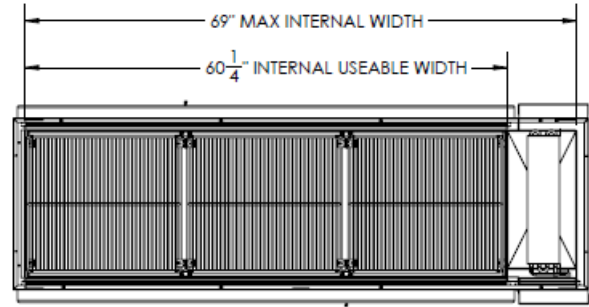

Plan View

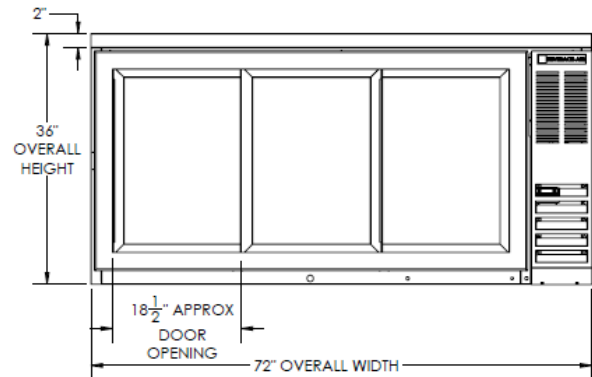

Elevation View

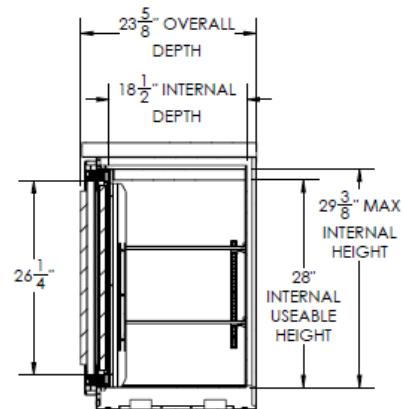

Side View

ELECTRICAL CONNECTION



115/60/1
NEMA-5-15P

Units pre-wired at
factory and include 8'
long cord and plug set.

