



**BEVERAGE-AIR**

Project: _____	AIA#
Item: _____	SIS#
Location: _____	
Approved: _____	

**BOTTOM MOUNT REACH-IN FREEZERS**

HBF49HC Glass Half-Door Bottom Mount Freezer  
Hydrocarbon Series

**MODEL:**  
HBF49HC-1-HG

**3 Year Parts/Labor Warranty**  
**Additional 4 Year Compressor Warranty**

**CABINET CONSTRUCTION**



- Stainless steel front, side, and grille (galvanized back & bottom)
- Stainless steel interior
- LED lighting
- Full electronic control with one-touch defrost
- Expansion valve technology
- One-piece grille allow easy removal/installation for preventative maintenance
- Self closing door with 120° stay open feature
- Spring-loaded style hinges
- Plug-in magnetic door gaskets
- Three (3) heavy duty epoxy coated wire shelves per door section
- 6" Casters with two (2) brakes

**OPTIONS & ACCESSORIES**

- Stainless steel universal tray slide pair, 1 tray slide set for (1) 18" x 26" or (2) 14" x 18" pans (AC)
- 3" caster or 6" legs
- Epoxy shelves
- Shelf clips
- Door locks
- Remote option\* (see note on back page)

**REFRIGERATION SYSTEM**

- Uses environmentally friendly, energy efficient R290 refrigerant, and meets all regulatory requirements for CARB, SNAP, DOE & more
- Hot gas condensate evaporator
- Adaptive defrost
- Epoxy coated evaporator coil
- Freezer capable of maintaining product temperature down to -10°F

**HBF49HC BOTTOM MOUNT MODELS: HORIZON SERIES**



Please verify qualifying units by visiting:  
[www.energystar.gov/cfs](http://www.energystar.gov/cfs)

3779 Champion Blvd., Winston-Salem, NC 27105  
1-888-845-9800 Fax: 1-336-245-6453  
Beverage-Air.com Sales@bevair.com



# BEVERAGE-AIR

MODEL	HBF49HC-1-HG
<b>EXTERNAL DIMENSIONAL DATA</b>	
Width Overall	52"
Depth Overall	33 3/4"
Height Overall (6" casters)	84 1/4"
Number of Doors	2
Depth with Door Open 90°	56"
Door Opening (inches)	(4) 22 3/4" x 24 5/8"
<b>INTERNAL DIMENSIONAL DATA</b>	
NET Capacity (cubic ft.)	46.2
Internal Width Overall (inches)	49"
Internal Depth Overall (inches)	26"
Internal Height Overall (in)	61 5/8"
Internal Height Useable (in)	53"
Number of Shelves	6
<b>ELECTRICAL DATA</b>	
Full Load Amperes 115/60/1	11.0
<b>REFRIGERATION DATA</b>	
Horsepower	3/4
Capacity (BTU/Hr)*	2312
<b>SHIPPING DATA</b>	
Gross Weight - Crated	651 lbs
Height - Crated	85"
Width - Crated	54"
Depth - Crated	36"

\*NOTE: Remote units are field wired and come with 6" legs. Refrigerant must be specified at time of order.

## Bottom Mount Reach-ins Freezer Model: HBF49HC-1-HG

### Model Views

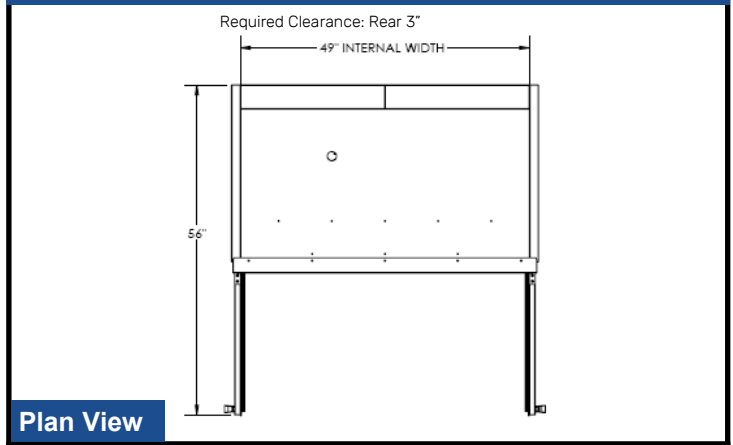

Plan View

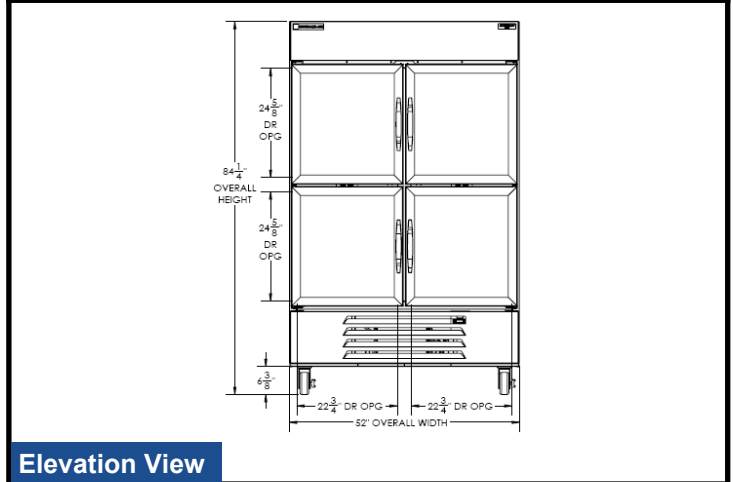

Elevation View

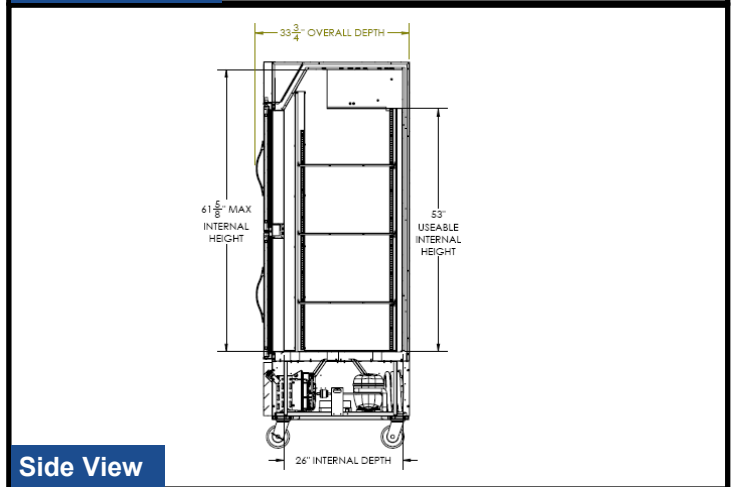

Side View

### ELECTRICAL CONNECTION



115/60/1  
NEMA-5-15P

Units pre-wired at factory and include 8' long cord and plug set.



3779 Champion Blvd., Winston-Salem, NC 27105 1-888-845-9800 Fax: 1-336-245-6453 Beverage-Air.com Sales@bevair.com

an Ali Group Company



The Spirit of Excellence