



BEVERAGE-AIR

Project: _____

AIA#

Item: _____

Location: _____

SIS#

Approved: _____

MARKETEER™ MERCHANDISERS

MT53 Black Hinged Door Model
Hydrocarbon Series

**MODEL:
MT53-1B**

MT53™ MERCHANDISER: HINGED DOOR MODEL



**3 Year Parts/Labor Warranty
Additional 4 Year Compressor Warranty**

CABINET CONSTRUCTION

- Standard cabinet exterior finish is heavy duty steel with a black baked on durable coating
- Heavy duty interior construction includes white coated steel
- Electronic temperature control
- Modern one piece grill
- Double pane lowE argon filled glass doors feature outside pane that is tempered for added safety
- Door locks standard
- Self-closing hinged glass door features, pocket door handle
- LED lighting
- Five (5) epoxy coated shelves per section
- 2" Leveling feet

OPTIONS & ACCESSORIES

- Extra shelves & clips
- 3" Casters
- Visiside shelving kit

REFRIGERATION SYSTEM

- Uses environmentally friendly, energy efficient R290 refrigerant, and meets all regulatory requirements for CARB, SNAP, DOE & more
- Condenser is designed to be low maintenance, and energy efficient.
- Automatic, non-electric defrost
- Epoxy coated evaporator coil



Please verify qualifying units by visiting:
www.energystar.gov/cfs

3779 Champion Blvd., Winston-Salem, NC 27105
1-888-845-9800 Fax: 1-336-245-6453
Beverage-Air.com Sales@bevair.com



BEVERAGE-AIR

MODEL	MT53-1B
EXTERNAL DIMENSIONAL	
Width Overall	54 1/4"
Depth Overall	29 1/8"
Height Overall	78 3/8"
Number of Doors	2
Depth with Door Open 90 °	54"
Clear Door Openings (in)	22 3/4" x 59 3/8" (2)
INTERNAL DIMENSIONAL DATA	
NET Capacity (cubic ft.)	41.66
Capacity 20 oz	480
Internal Width Overall (in)	50"
Internal Depth Overall (in)	20 7/8"
Internal Height Overall (in)	59 11/16"
Internal Height Useable (in)	54"
Number of Shelves	10
ELECTRICAL DATA	
Full Load Amperes 115/60/1	8.7
REFRIGERATION DATA	
Horsepower	1/2+
Energy Consumption	3.290 kWh/day
SHIPPING DATA	
Gross Weight - Crated	484 lbs
Height - Crated	85 3/8"
Width - Crated	57"
Depth - Crated	33"

Glass Hinged Door Model

Model: MT53-1B

Model Views

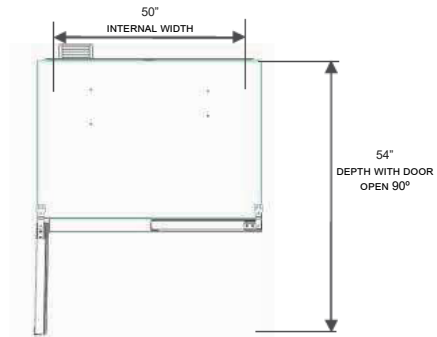

Plan View

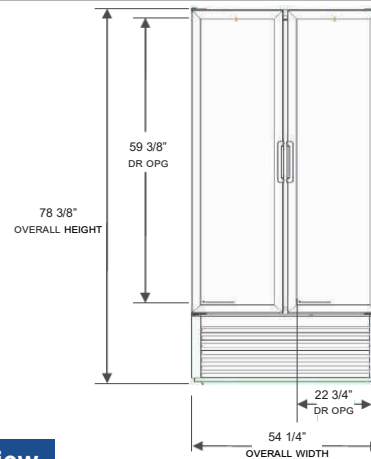

Elevation View

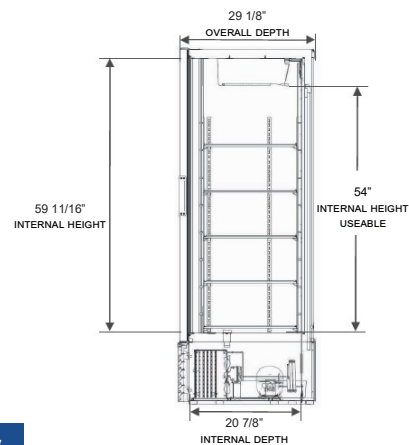

Side View

ELECTRICAL CONNECTION



115/60/1
NEMA-5-15P

Units pre-wired at factory and include 8' long cord and plug set.



3779 Champion Blvd., Winston-Salem, NC 27105 1-888-845-9800 Fax: 1-336-245-6453 Beverage-Air.com Sales@bevair.com

an Ali Group Company



The Spirit of Excellence