



BEVERAGE-AIR

Project: _____

AIA#

Item: _____

Location: _____

SIS#

Approved: _____

SPED ELITE SERIES FOOD PREPARATION TABLES

MODELS:
SPED72HC-10-4

SPED72HC Sandwich Prep Table with Drawers

Hydrocarbon Series

3 Year Parts/Labor Warranty
Additional 2 Year Compressor Warranty

CABINET CONSTRUCTION



SPED72HC-10-4

- Stainless steel front, sides, top, door, drawers, and grille (galvanized steel back & bottom)
- Interior liner is made of corrosion resistant aluminum
- Removable hoods & insulated lid assemblies are made of matching stainless steel
- Self-closing door on cartridge style hinges, 120° stay-open door feature
- Easy door removal for service and cleaning
- Field-reversible door with snap-in door gaskets
- Painted aluminum door and drawer handles
- 6" Casters, 2 with brakes standard
- Two epoxy-coated steel wire shelves standard
- 10" Wide cutting board constructed of white polyethylene plastic
- Cutting board removable for cleaning
- Pans furnished are 4" deep constructed of polycarbonate plastic
- Stainless steel drawer frames supported on telescoping drawer slides
- Drawer slides include locking mechanism that prevents drawers from being inadvertently pulled off cabinet
- Top and bottom drawers accommodate 6" deep pans
- Maintains product temperature between 36° - 38°F

OPTIONS & ACCESSORIES

- Stainless steel back options
- Stainless steel interior options
- Overshelves (single or double)
- Crumb catcher
- Modified pan openings
- 6" Legs
- 3" Casters
- Low profile casters
- Richlite cutting board
- Night cover
- Remote option

REFRIGERATION SYSTEM

- Refrigeration system uses R290 refrigerant to comply with all environmental concerns
- Automatic, non-electric defrost
- Epoxy coated evaporator coil

SPED72HC Elite Series Sandwich Prep: Cutting Top Series



3779 Champion Blvd., Winston-Salem, NC 27105
1-888-845-9800 Fax: 1-336-245-6453
Beverage-Air.com sales@bevair.com



BEVERAGE-AIR

MODEL	SPED72HC-10-4
EXTERNAL DIMENSIONAL DATA	
Width Overall	72"
Depth Overall	32"
Height Overall 6" with Casters	45 1/8"
Number of Doors	1
Depth with Door Open 90°	52 1/4"
Door Opening (in)	19 1/2" x 21 5/8"
Number of Drawers	4
Depth with Top Drawers Open Extended	47 7/8"
Drawer Opening (in)	Upper 19 1/2" x 11 1/4" Lower 19 1/2" x 7 1/2"
Depth, Cutting Board	10"
INTERNAL DIMENSIONAL DATA	
NET Capacity (cubic ft.)	20.02
Internal Width Overall (in)	68"
Internal Depth Overall (in)	23 1/2"
Internal Depth Useable (in)	Upper 18 1/2" Lower 15 3/8"
Internal Height Overall (in)	23"
Internal Height Useable (in)	16"
Number of Shelves	2
Number of Pans	(10) 1/6 Size
ELECTRICAL DATA	
Full Load Amperes 115/60/1	5.4
REFRIGERATION DATA	
Horsepower	1/3
Capacity (BTU/Hr)*	1549
WEIGHT DATA	
Gross Weight (Crated lbs)	450 lbs
Height - Crated	43"
Width - Crated	74"
Depth - Crated	33"

Food Preparation Table — Cutting Top Models: SPED72HC-10-4

Model Views

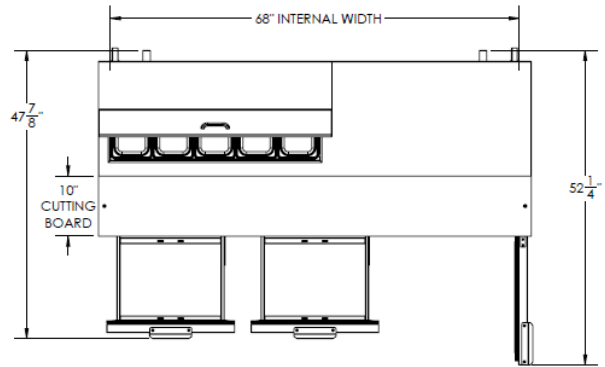

Plan View

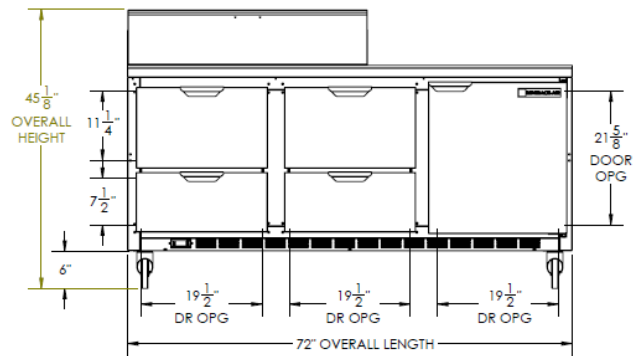

Elevation View

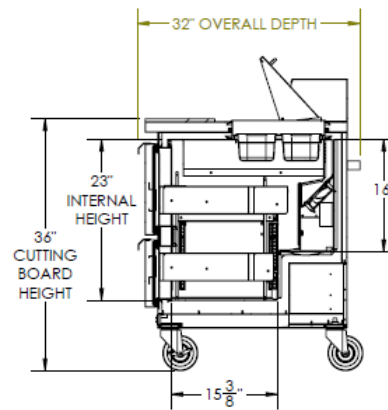

Side View

ELECTRICAL CONNECTION



115/60/1
NEMA-5-15P

Units pre-wired at factory and include 8' long cord and plug set.



an Ali Group Company



The Spirit of Excellence

3779 Champion Blvd., Winston-Salem, NC 27105
1-888-845-9800 Fax: 1-336-245-6453
Beverage-Air.com sales@bevair.com