



# BEVERAGE-AIR

Project: _____	AIA#
Item: _____	
Location: _____	SIS#
Approved: _____	

## PH REACH-IN TOP MOUNT WARMING CABINET

**MODEL:  
PH2-1HS**

### PH2 Half-Solid Double Door Warming Cabinet



**PH2-1HS**

**3 Year Parts/Labor Warranty  
Additional 2 Year Compressor Warranty**

#### CABINET CONSTRUCTION

- Stainless steel exterior and interior
- Operational indicator panel contains thermometer and adjustable thermostat control which is accurately calibrated from 80°F to 180°F
- Manually controlled humidity vents are provided in the top of the cabinet
- Self closing doors with safety stops
- Heavy-duty cylinder lock and self-adjusting magnetic gasket
- Stainless steel breaker
- Cam-lift hinges
- Anti-microbial door handles
- Three (3) silver freeze shelves
- 6" Adjustable legs standard

#### OPTIONS & ACCESSORIES

- Pan slides
- 3" or 6" Casters

#### ELECTRICAL SYSTEM

- 20 AMP breaker required for double door units
- Strip type 750-watt heating elements, operating on 208-240/60/1, having a total of 1500 watts per compartment.
- Externally mounted blower system maintains even temperature through out the food zone area.

PH2 Top Mount Models: Warming Cabinet



3779 Champion Blvd., Winston-Salem, NC 27105  
1-888-845-9800 Fax: 1-336-245-6453  
Beverage-Air.com sales@bevair.com



# BEVERAGE-AIR

## Warming Cabinet Model: PH2-1HS

MODEL	PH2-1HS
<b>EXTERNAL DIMENSIONAL DATA</b>	
Width Overall	52 1/8"
Depth Overall with Handle	34 5/8"
Height Overall with Legs	83 3/4"
Number of Doors	4
Depth with Door Open 90°	57 5/8"
Door Opening (in)	21 1/2" x 24 1/4"
<b>INTERNAL DIMENSIONAL DATA</b>	
NET Capacity (cubic ft.)	43.3
Internal Width Overall (in)	48 1/8"
Internal Depth Overall (in)	26"
Internal Height Overall (in)	56 5/8"
<b>ELECTRICAL DATA</b>	
Cabinet Voltage 208-240	208-240
Max. Fuse Size T.D.	15 AMPS
Feed Wires	2
Heater Watts per section (@240V)	1500
Total Wattage (Heaters & Fan @240V)	3000
Total AMPS	6.3
<b>WEIGHT DATA</b>	
Gross Weight (Crated lbs)	460 lbs
Height - Crated	87"
Width - Crated	60"
Depth - Crated	45"

### Model Views

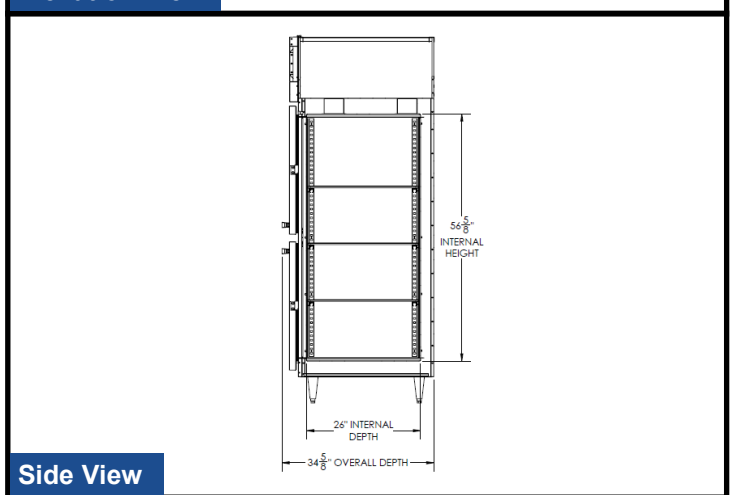
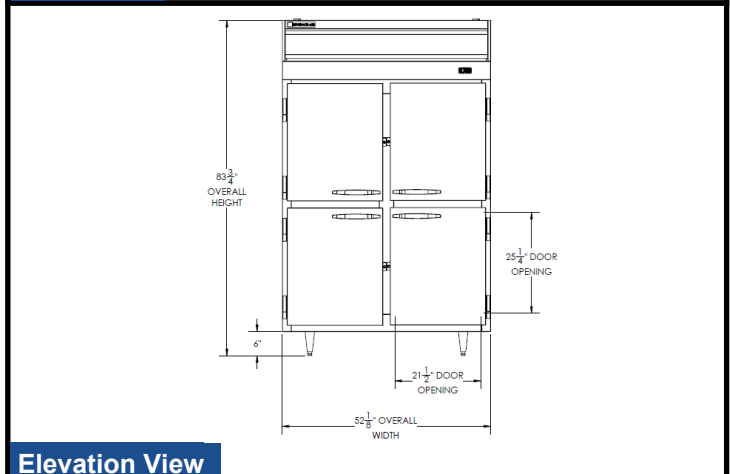
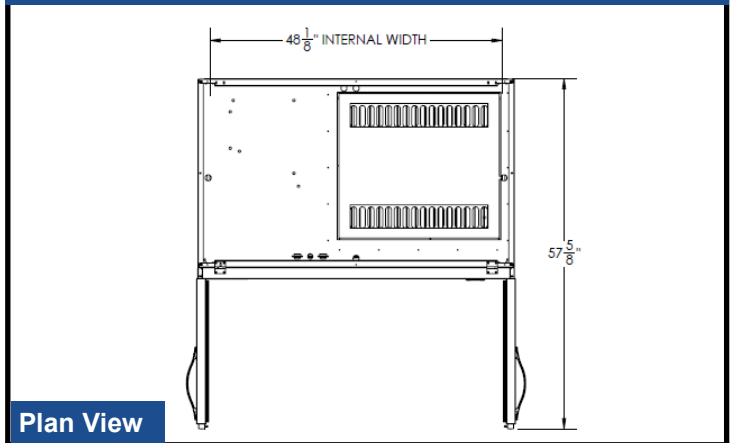

### ELECTRICAL CONNECTION



208-240/60/1  
NEMA 6-20A

Units pre-wired at factory and include 8' long cord and plug set.



an Ali Group Company



The Spirit of Excellence

3779 Champion Blvd., Winston-Salem, NC 27105  
1-888-845-9800 Fax: 1-336-245-6453  
Beverage-Air.com sales@bevair.com