



BEVERAGE-AIR

Project: _____

AIA#

Item: _____

Location: _____

SIS#

Approved: _____

UCRD UNDERCOUNTER REFRIGERATOR

UCRD119AHC Door & Drawer Combination

Hydrocarbon Series

MODELS:

UCRD119AHC-4

3 Year Parts/Labor Warranty
Additional 2 Year Compressor Warranty

CABINET CONSTRUCTION

- Stainless steel front, sides, top, doors and drawers, (*galvanized back & bottom*)
- Interior liner is made of corrosion resistant aluminum
- Full electronic control
- Interior thermometer is standard
- Durable sub-top 1/2" insulated for added durability
- Self-closing doors with 120° Stay-open feature, on cam-lift hinges
- Easy door removal for service and cleaning
- Magnetic gaskets attached to each door and drawer for positive seal
- Painted aluminum door and drawer handles
- 6" Casters, three (3) with brakes standard
- Four (4) epoxy-coated steel wire shelves standard
- Stainless steel drawer frames supported on telescoping drawer slides
- Drawer slides include locking mechanism that prevents drawers from being inadvertently pulled off cabinet
- Maintains product temperature between 36°F and 38°F



UCRD119AHC-4

OPTIONS & ACCESSORIES

- Stainless steel back and grille
- Stainless steel interior
- Right or left hinged door
- Locks (solid doors only)
- Bun rack
- Wire shelf divider
- 3" Casters or 6" legs
- Low profile casters
- Remote option

REFRIGERATION SYSTEM

- Refrigeration system uses R290 refrigerant to comply with all environmental concerns
- Automatic, non-electric defrost
- Epoxy coated evaporator coil

UCRD119AHC-4 Undercounter Refrigerator: Food Prep Series



3779 Champion Blvd., Winston-Salem, NC 27105
1-888-845-9800 Fax: 1-336-245-6453
Beverage-Air.com sales@bevair.com



BEVERAGE-AIR

Undercounter Refrigerators Door & Drawer Combination Models: UCRD119AHC-4

MODEL	UCRD119AHC-4
EXTERNAL DIMENSIONAL DATA	
Width Overall	119"
Depth Overall	32 7/8"
Height Overall with 6" Casters	34 1/2"
Number of Doors	2
Depth with Door Open 90 °	55 1/8"
Number of Drawers	4
Drawer Open Extended	55 1/2"
Drawer Opening (in)	Upper 21 5/8 X 10 3/8" Lower 21 5/8" x 10 1/4"
INTERNAL DIMENSIONAL DATA	
NET Capacity (cubic ft.)	40.5
Internal Width Overall (in)	99 7/8"
Internal Depth Overall (in)	26"
Internal Height Overall (in)	25"
Number of Shelves	4
ELECTRICAL DATA	
Full Load Amperes 115/60/1	5.0
REFRIGERATION DATA	
Horsepower	1/3
Capacity (BTU/Hr)*	2629
WEIGHT DATA	
Gross Weight (Crated lbs)	563 lbs
Height - Crated	47 1/2"
Width - Crated	122"
Depth - Crated	37"

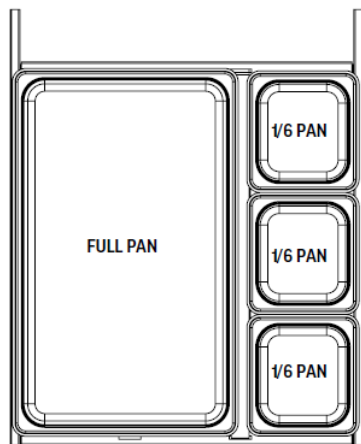

UCRD46 / UCRD67 / UCRD93 / UCRD119
UCFD46 / UCFD67 / UCFD93 / UCFD119



Model Views

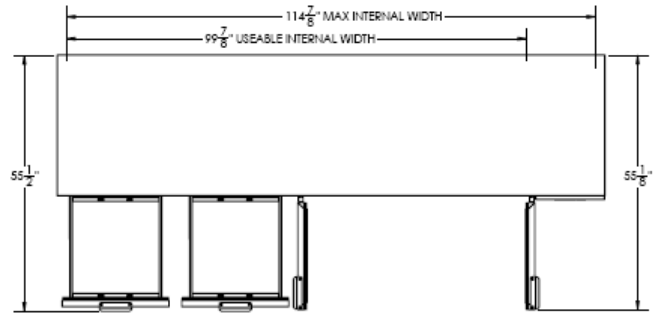

Plan View

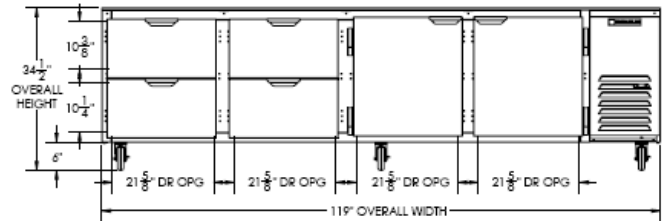

Elevation View

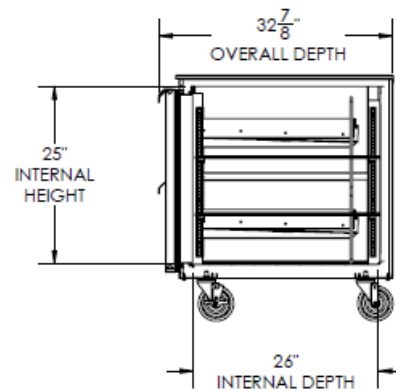

Side View

ELECTRICAL CONNECTION



115/60/1
NEMA-5-15P

Units pre-wired at factory and include 8' long cord and plug set.



an Ali Group Company



The Spirit of Excellence

3779 Champion Blvd., Winston-Salem, NC 27105
1-888-845-9800 Fax: 1-336-245-6453
Beverage-Air.com sales@bevair.com