



# BEVERAGE-AIR

Project: _____	AIA#
Item: _____	SIS#
Location: _____	
Approved: _____	

## WTF WORKTOP FREEZER

WTF32AHC Solid Door Flat Top Freezer  
Hydrocarbon Series

**MODELS:**  
WTF32AHC-FLT

WTF32AHC Worktop Freezer: Food Prep Series

**3 Year Parts/Labor Warranty**  
**Additional 2 Year Compressor Warranty**



WTF32AHC-FLT

### CABINET CONSTRUCTION

- Stainless steel front, sides, top, doors, (*galvanized steel back & bottom*)
- Interior liner is made of corrosion resistant aluminum
- Full electronic control
- Stainless steel top for added durability
- Flat top
- Interior thermometer is standard
- Easy door removal for service and cleaning
- Magnetic gaskets attached to each door for positive seal
- Painted aluminum door handles
- 6" Casters, two (2) with brakes standard
- Two epoxy-coated steel wire shelves
- Field reversible doors
- Freezer temperatures is held at 0°F or below

### OPTIONS & ACCESSORIES

- Stainless steel back and grille
- Stainless steel interior
- Right or left hinged door
- Locks (solid doors only)
- Wire shelf divider
- 3" Casters or 6" legs
- Low profile casters
- Remote option

### REFRIGERATION SYSTEM

- Refrigeration system uses R290 refrigerant to comply with all environmental concerns
- Automatic, non-electric defrost
- Epoxy coated evaporator coil



3779 Champion Blvd., Winston-Salem, NC 27105  
1-888-845-9800 Fax: 1-336-245-6453  
Beverage-Air.com sales@bevair.com



# BEVERAGE-AIR

MODEL	WTF32AHC-FLT
<b>EXTERNAL DIMENSIONAL DATA</b>	
Width Overall	32"
Depth Overall with Handle & Bumper	32"
Height Overall with 6" casters	35 1/2"
Number of Doors	1
Depth with Door Open 90°	60 1/8"
Door Opening (in)	27 5/8 x 21 5/8"
<b>INTERNAL DIMENSIONAL DATA</b>	
NET Capacity (cubic ft.)	7.2
Internal Width Overall (in)	28"
Internal Depth Upper (in)	18 1/4"
Internal Depth Lower (in)	15 3/8"
Internal Height Overall (in)	23"
Number of Shelves	2
<b>ELECTRICAL DATA</b>	
Full Load Amperes 115/60/1	4.0
<b>REFRIGERATION DATA</b>	
Horsepower	1/3+
Capacity (BTU/Hr)*	1184
<b>WEIGHT DATA</b>	
Gross Weight (Crated lbs)	220 lbs
Height - Crated	40"
Width - Crated	32"
Depth - Crated	32"

## Worktop Freezer

Models: WTF32AHC-FLT

### Model Views

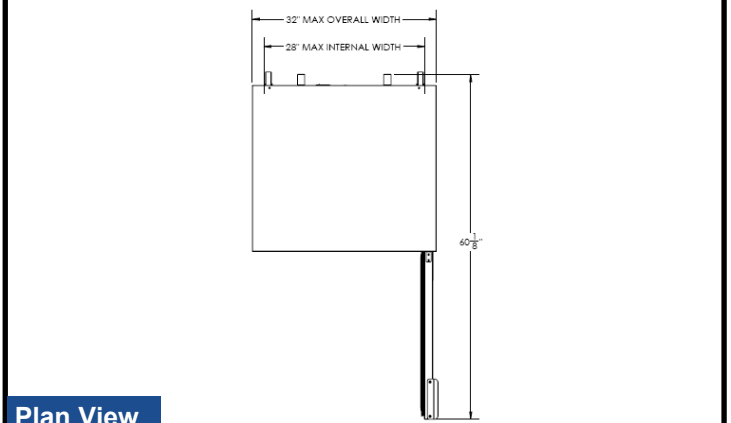

Plan View

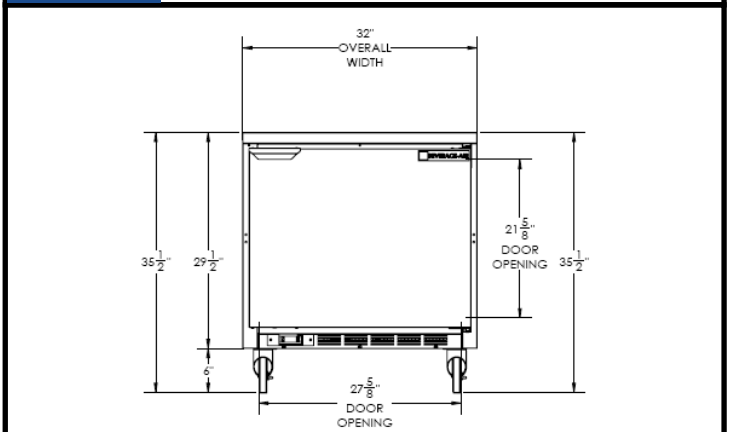

Elevation View

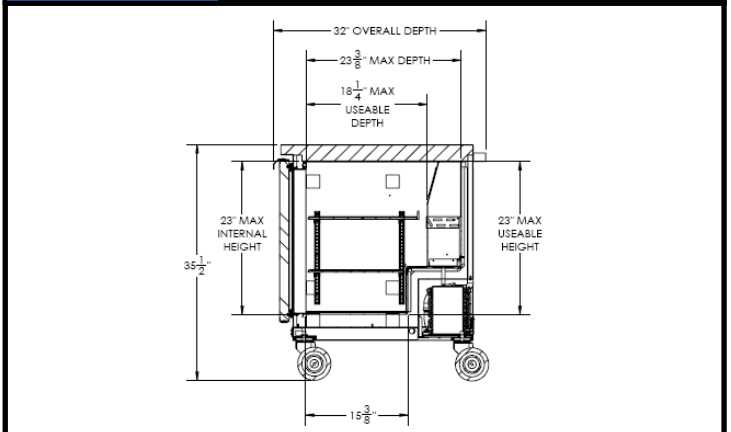

Side View

### ELECTRICAL CONNECTION



115/60/1  
NEMA-5-15P

Units pre-wired at factory and include 8' long cord and plug set.



an Ali Group Company



The Spirit of Excellence

3779 Champion Blvd., Winston-Salem, NC 27105  
1-888-845-9800 Fax: 1-336-245-6453  
Beverage-Air.com sales@bevair.com