



BEVERAGE-AIR

Project: _____

AIA#

Item: _____

Location: _____

SIS#

Approved: _____

WTR WORKTOP REFRIGERATOR WTR46AHC Worktop Refrigerators Hydrocarbon Series

**MODELS:
WTR46AHC**

WTR46AHC Worktop Refrigerator: Worktop Series

**3 Year Parts/Labor Warranty
Additional 2 Year Compressor Warranty**

CABINET CONSTRUCTION



WTR46AHC

- Stainless steel front, sides and door, *(galvanized back & bottom)*
- Interior liner is made of corrosion resistant aluminum
- Stainless steel top
- 4" Built-in backsplash
- Full electronic control
- Interior thermometer is standard
- Self-closing doors with 120° stay-open feature, on cam-lift hinges
- Easy door removal for service and cleaning
- Magnetic gasket attached to each door for positive seal
- Painted aluminum door handle
- 6" Casters, two (2) with brakes standard
- Two epoxy-coated steel wire shelves standard
- Field reversible door
- Maintains product temperature between 36°F and 38°F

OPTIONS & ACCESSORIES

- Stainless steel back and grille
- Stainless steel interior
- Right or left hinged door
- Locks (solid doors only)
- Bun rack
- Wire shelf divider
- Cutting board
- 3" Casters or 6" legs
- Low profile casters
- Remote option

REFRIGERATION SYSTEM

- Refrigeration system uses R290 refrigerant to comply with all environmental concerns
- Automatic, non-electric defrost
- Epoxy coated evaporator coil



3779 Champion Blvd., Winston-Salem, NC 27105
1-888-845-9800 Fax: 1-336-245-6453
Beverage-Air.com sales@bevair.com



BEVERAGE-AIR

MODEL	WTR46AHC
EXTERNAL DIMENSIONAL DATA	
Width Overall	46"
Depth Overall with Countertop	34"
Height Overall with 6" Casters	39 1/2"
Number of Doors	1
Depth with Door Open 90 °	55 1/8"
Door Opening (in)	21 1/2" x 23 3/8"
INTERNAL DIMENSIONAL DATA	
NET Capacity (cubic ft.)	10.8
Internal Width Overall (in)	27"
Internal Depth Overall (in)	26"
Internal Height Overall (in)	24 3/4"
Number of Shelves	2
ELECTRICAL DATA	
Full Load Amperes 115/60/1	3.0
REFRIGERATION DATA	
Horsepower	1/6
Capacity (BTU/Hr)*	1350
WEIGHT DATA	
Gross Weight (Crated lbs)	290 lbs
Height - Crated	46 1/2"
Width - Crated	49"
Depth - Crated	37"

Worktop Refrigerator

Models: WTR46AHC

Model Views

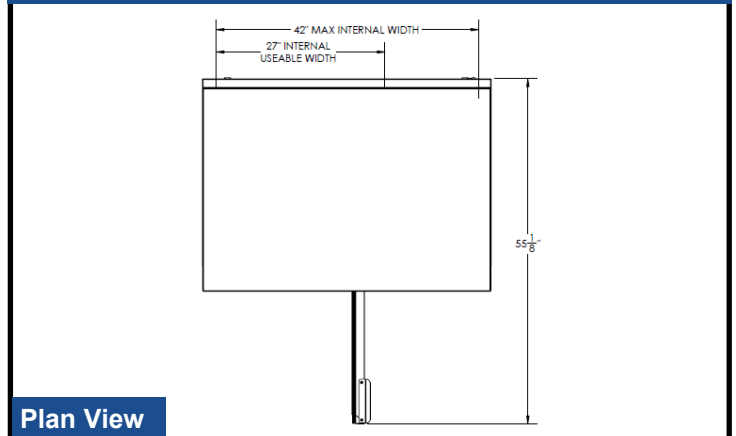

Plan View

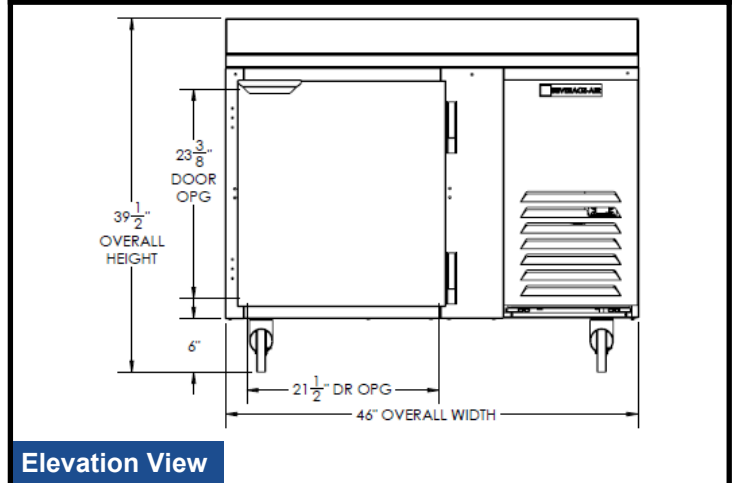

Elevation View

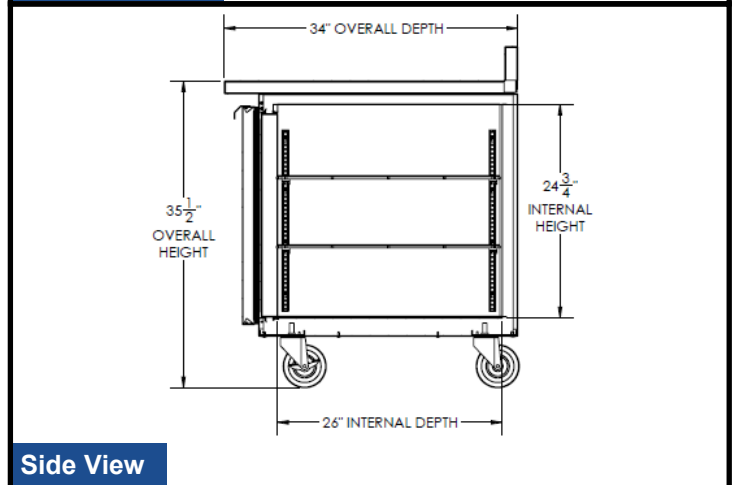

Side View

ELECTRICAL CONNECTION



115/60/1
NEMA-5-15P

Units pre-wired at factory and include 8' long cord and plug set.



an Ali Group Company



The Spirit of Excellence

3779 Champion Blvd., Winston-Salem, NC 27105
1-888-845-9800 Fax: 1-336-245-6453
Beverage-Air.com sales@bevair.com