



ADA Compliant

This Space for Architect/Engineer Approval

Job Name _____ Date _____

Model Specified _____ Quantity _____

Customer/Wholesaler _____

Contractor _____

Architect/Engineer _____

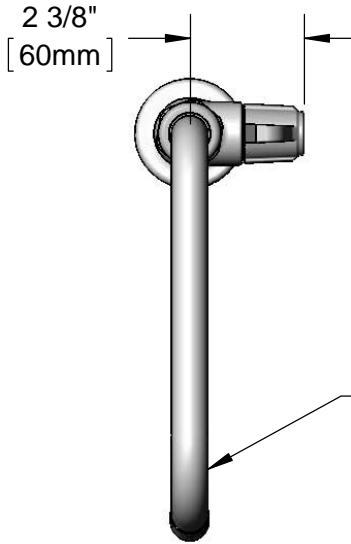

5SP-08
8" equip Swing Nozzle
w/ Laminar Flow Device.
Rigid Conversion Requires
014200-45 Lock Washer
(Included)

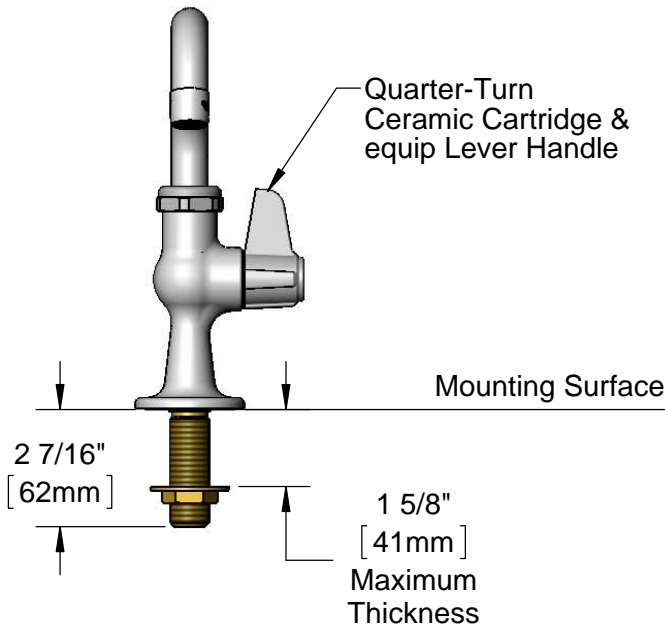

Quarter-Turn
Ceramic Cartridge &
equip Lever Handle

Mounting Surface

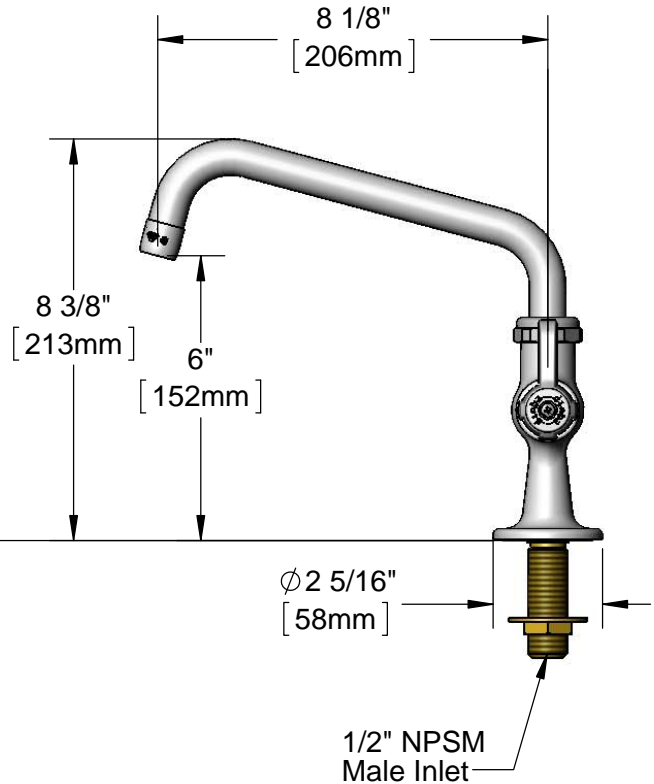

Rough-In Requirement:
Ø 1" [25mm] Mounting Hole

Model Number
5F-1SLX08

Product Specifications:
Single Supply Deck Mount Faucet w/ Quarter-Turn Ceramic Cartridge, equip Lever Handle, 8" equip Swing Nozzle & 1/2" NPSM Male Inlet

Product Compliance:
ASME A112.18.1 / CSA B125.1
NSF 61 - Section 9
NSF 372 (Low Lead Content)
ANSI A117.1 (ADA)

equip
Foodservice
Accessories



2 Saddleback Cove, P.O. Box 1088
Travelers Rest, South Carolina 29690
Phone: 800.891.4808 Fax: 800.868.0084
equip.tsbrass.com

ITEM NO.	SALES NO.	DESCRIPTION
1	014250-45	Laminar Flow Device
2	5SP-08	8" equip Swing Nozzle
3	013839-25	equip Swivel Nut
4	013848-45	equip Swivel Piece O-Ring
5	014200-45	Star Washer, Anti-Rotation
6	5-HDL-L	equip Lever Handle
7	013849-45	Plain Handle Screw (10)
8	013787-45	equip Ceramic Cartridge, RTC
9	014612-45	Deck Seal
10	000999-45	Brass Lock Washer
11	002954-45	Shank Lock Nut

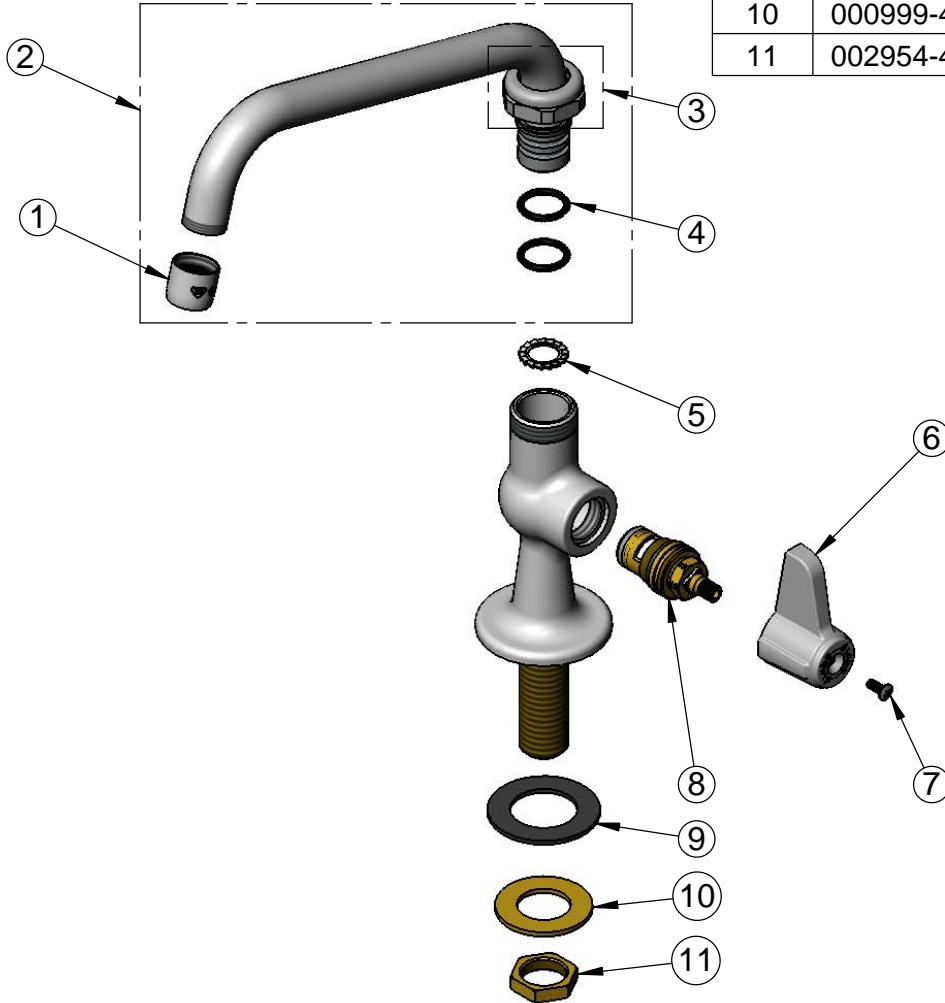

Model Number

5F-1SLX08

Product Specifications:

Single Supply Deck Mount Faucet w/ Quarter-Turn Ceramic Cartridge, equip Lever Handle, 8" equip Swing Nozzle & 1/2" NPSM Male Inlet

Product Compliance:

ASME A112.18.1 / CSA B125.1
NSF 61 - Section 9
NSF 372 (Low Lead Content)
ANSI A117.1 (ADA)

equip
Foodservice
Accessories

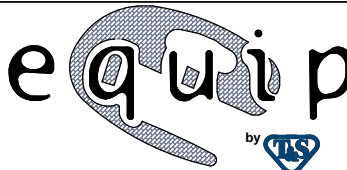

2 Saddleback Cove, P.O. Box 1088
Travelers Rest, South Carolina 29690
Phone: 800.891.4808 Fax: 800.868.0084
equip.tsbrass.com