



Item No. \_\_\_\_\_  
 Project \_\_\_\_\_  
 Quantity \_\_\_\_\_

**ChefSeries™ Gas, Counter Model Griddles, Extended Depth Model: [224,236,248,260,272][ZTD/ZTDC]**



Model 236ZTD

**SIZING AND PERFORMANCE GUIDE**

Model	Unit Width	Approx. Surface Area	Burners	Approx. BTU Input*
<input type="checkbox"/> 224ZT	24"	720 sq. in.	2	70,000
<input type="checkbox"/> 236ZT	36"	1080 sq. in.	3	105,000
<input type="checkbox"/> 248ZT	48"	1440 sq. in.	4	140,000
<input type="checkbox"/> 260ZT	60"	1800 sq. in.	5	175,000
<input type="checkbox"/> 272ZT	72"	2160 sq. in.	6	210,000

\* For both natural and propane gas

**SHORT/BID SPECIFICATION**

Griddle shall be a **LANG Manufacturing Model** \_\_ [specify width: **24", 36", 48", 60" or 72"**]\_\_ with:  ACCU-TEMP Snap-action Thermostat Controls [ZTD],  ACCU-TEMP Snap-action Thermostat Controls with chrome plate [ZTDC], gas heated aluminized burner system, with bottom baffles and direct spark electronic ignition; 1" thick polished cooking surface; 5-1/2" high side and back splash and full front 1" deep x 3-1/2" wide grease trough; double wall base construction; and all the features listed and the options/ accessories checked:

**STANDARD PRODUCT WARRANTY**

- Three year parts & labor
- 5 year guarantee on chrome plated surfaces when ordered

**CONSTRUCTION FEATURES**

- 1" thick precision machined, polished steel cooking surface
- Continuously bottom welded 5-1/2" high rear & side splash shields
- Full front 3-1/2" wide X 1" deep stainless steel grease trough with...
- One or two [48", 60" & 72" models] drops provided to one or two grease drawers
- Double wall base construction
- Aluminized burner system spaced every 12"
- Heat shield provided below burners
- 4" adjustable legs provided [Stand option available]

**PERFORMANCE FEATURES**

- Thick griddle plate reduces hot & cold spots and retains heat
- Highly polished surface and continuously welded splash and grease trough speed cleanup
- Electronic spark ignition, double wall construction and heat shields increase operating efficiency
- Double wall construction and heat shells reduce side, back and bottom clearances

**CONTROL PACKAGE**

- ACCU-TEMP™ Thermostat Controls [-T]**
  - Snap-action thermostats
  - Independent temperature control every 12"
  - Electronic ignition, griddle-ON switch
  - 200° and 550°F temperature control range

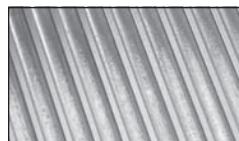

**FOCUS OPTION**

Custom Grooving [Specified in 12" increments, from left to right. 24" maximum, from either side.]



Sheet No. **LSP-CSGD** (rev. 04/13)

# ChefSeries™ Gas, Counter Model Griddles, Extended Depth Model: [224,236,248,260,272][ZTD/ZTDC]

## INSTALLATION REQUIREMENTS

- (G) Specify:  natural gas or  propane gas: via 3/4" NPT connection
  - Gas pressure regulator provided
  - Specify elevation if project is over 2000 feet.
  - (E) 115V, 1-Phase, 50/60 Hz, 2-AMP electrical connection
  - Cord & plug is provided
  - Installation under approved vent hood required.
- [All connections from rear. See below for location and delivery requirements]

## OPTIONS & ACCESSORIES

- Custom Grooving [Specified in 12" increments, from left to right, 24" maximum, from either side.]
- Stainless steel tubular-leg stand with adjustable feet
- Stainless steel tubular-leg stand with casters & shelf
- Clamshell™ two sided cooking
- Chrome plated griddle surface

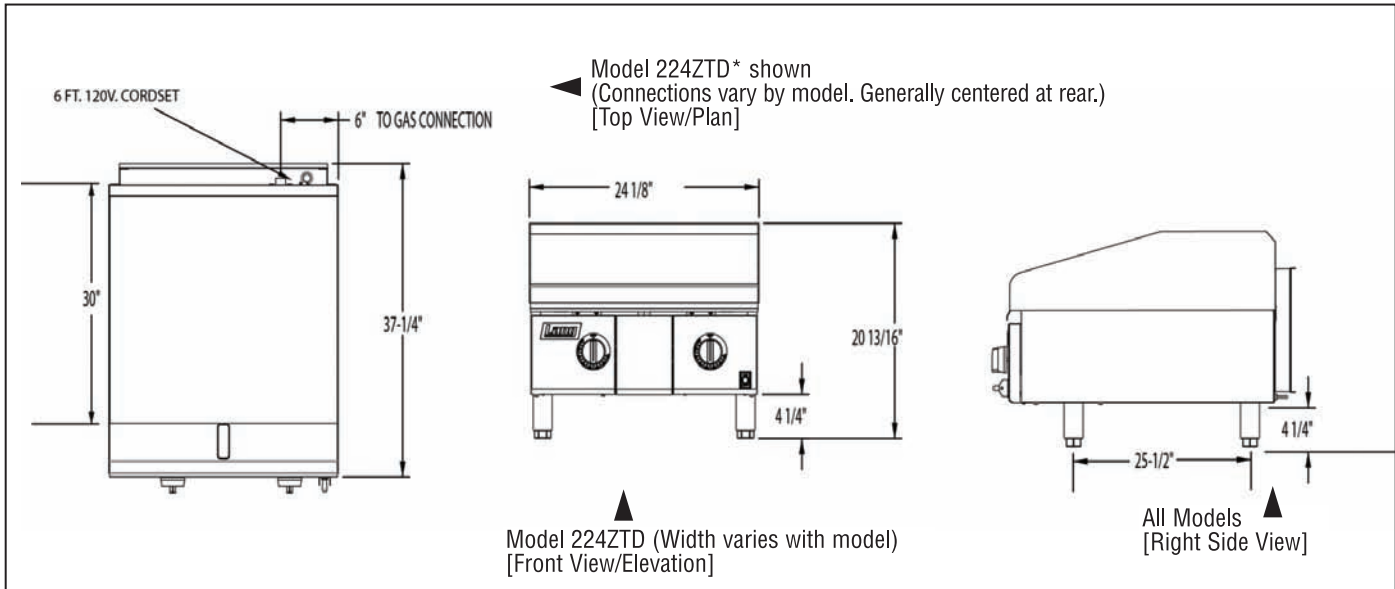

Model	Height x Width x Depth (Not including legs)	Clearance from combustible surface	Weight		Freight Class
			Actual	Shipping	
224ZTD	16.5" x 24.0" x 37.25" 420mm x 610mm x 943mm	Sides: 4" Back: 4" Bottom: 4"	400 lbs. 181 kg	440 lbs. 199 kg	85
236ZTD	16.5" x 36.0" x 37.25" 420mm x 914mm x 943mm		530 lbs. 240 kg	565 lbs. 256 kg	85
248ZTD	16.5" x 48.0" x 37.25" 420mm x 1219mm x 943mm		680 lbs. 308 kg	730 lbs. 331 kg	85
260ZTD	16.5" x 60" x 37.25" 420mm x 1524mm x 943mm		820 lbs. 372 kg	870 lbs. 395 kg	85
272ZTD	16.5" x 72.0" x 37.25" 420mm x 1830mm x 943mm		960 lbs. 435 kg	1020 lbs. 463 kg	85

Model	(E) Electrical Requirements				(G) Gas Requirements (3/4" NPT)
	Voltage	Total kW	Phase	Amps/Line	
224ZTD	115V/60Hz	0.5	1	2.0	70,000 BTU/hr
236ZTD					105,000 BTU/hr
248ZTD					140,000 BTU/hr
260ZTD					175,000 BTU/hr
272ZTD					210,000 BTU/hr

## CAD SYMBOLS & PRICING



Due to continuous improvements, specifications subject to change without notice.



Sheet No. LSP-CSGD (rev. 04/13)