



**John  
BOOS**  
Since 1887

ITEM #: \_\_\_\_\_ QTY: \_\_\_\_\_

MODEL #: \_\_\_\_\_

PROJECT NAME: \_\_\_\_\_

071717

3601 S. Banker St. Effingham, IL 62401 • P.O. BOX 609 • Ph: (888) 431-2667 • Fax: (800) 433-2667

## **"CWC" WIRE BUSSING CART W/ CHROME PLATING** **W/ LOCKING CASTERS AND NUMBERED POSTS**

### **FEATURES:**

- CHROME WIRE CART
- 18" WIDE X 36" LONG
- 3 ADJUSTABLE SHELVES
- NUMBERED POSTS
- 3" LOCKING CASTER WITH BUMPERS

### **CONSTRUCTION:**

- 1" DIAMETER CHROME PLATED FRAME  
W/ CHROME PLATED WIRE SHELVES

### **MATERIAL:**

- CHROME PLATED STEEL



CWC-1836-3

### **WIRE BUSSING CART**

MODEL #	QTY
CWC-1836-3	

# DETAILED SPECIFICATIONS

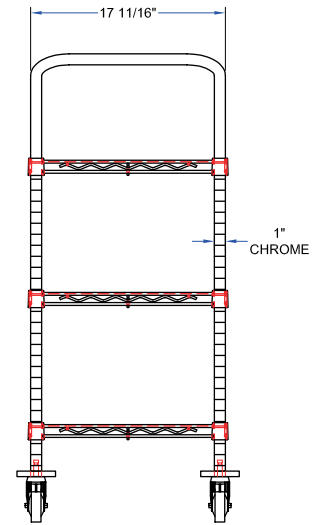
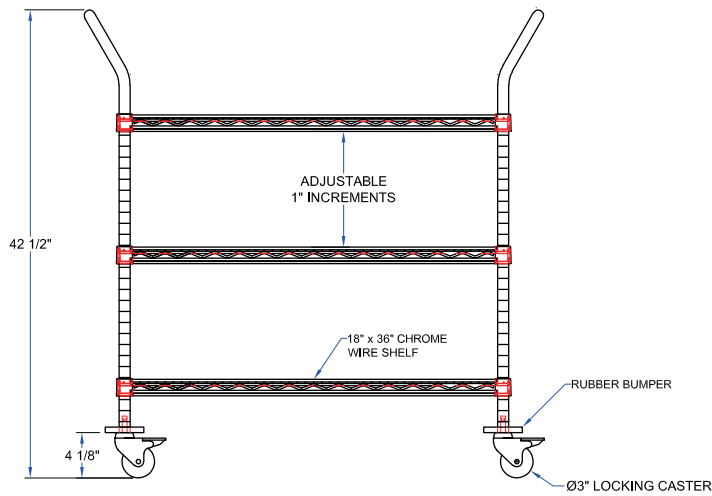
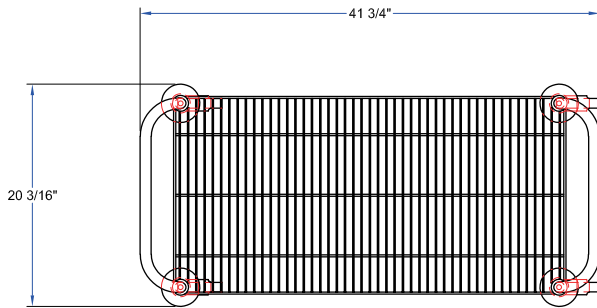

## WIRE BUSSING CART

MODEL #	TIER	WIDTH	DEPTH	WEIGHT (LBS)
CWC-1836-3	3	36"	18"	45

SOME UNITS SHIP UNASSEMBLED FOR REDUCED SHIPPING COST. ALL DIMENSIONS ARE TYPICAL. TOLERANCE +/- .500"  
 John Boos & Co. is constantly engaged in a program of improving products and therefore reserves the right to change specifications without prior notice.



3601 S. Banker St. • Effingham, IL 62401 • PO BOX 609 • [quotes@johnboos.com](mailto:quotes@johnboos.com)

[www.johnboos.com](http://www.johnboos.com)

071717

795