

Job: \_\_\_\_\_

Item: \_\_\_\_\_

Quantity: \_\_\_\_\_

## Chicken Dolly

Specifically designed to stack iced or frozen food. This dolly keeps drips, spills, and condensation to a minimum with a sturdy removable drip pan.

- Framework is constructed out of 1"x1"x.070" wall tubing.
- Laterals are constructed out of ½" x 1¼" oval tubing.
- Removable drip tray is constructed out of .063" aluminum sheet.
- Equipped with four 5" stem type swivel casters.
- Five-Year Guarantee against material defects and workmanship.
- Lifetime Guarantee against rust and corrosion.
- NSF Certified.



1187

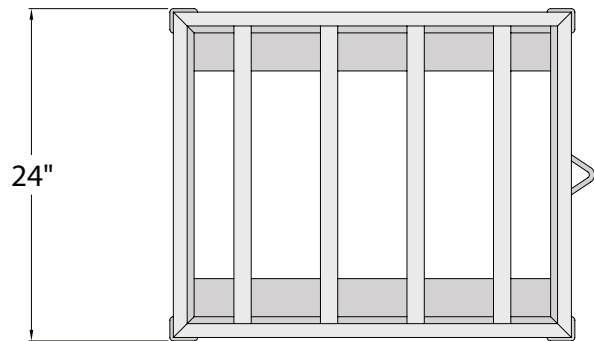
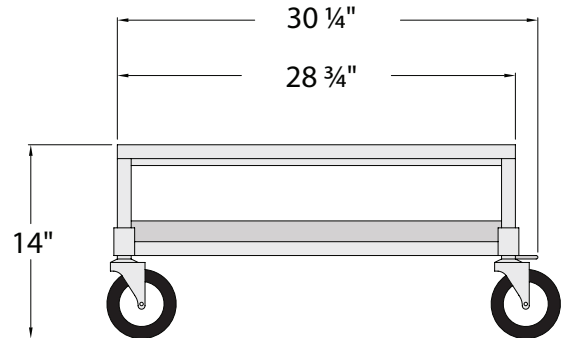

| Model No.                   | Size W-H-D       | Wt. Cap. | Ship Lbs. |
|-----------------------------|------------------|----------|-----------|
| 1187                        | 24" x 14" x 30¼" | 500 lbs. | 24        |
| <b>Replacement Drip Pan</b> |                  |          |           |
| 1188                        |                  |          | 5         |
| <b>Aluminum Drag Hook</b>   |                  |          |           |
| 1199                        | 37½" Long        |          | 1         |

Four 5" stem type casters -two swivel (#C480), two w/ brake (#C485).  
Comes equipped with drip pan.

Distributed by:

*This information is for general sales and engineering use only. New Age Industrial reserves the right to modify or make changes at any time without notice to materials and specifications.*

