

Job: _____

Item: _____

Quantity: _____

50929 - 1/2-Size Enclosed Bun Pan Rack

APPLICATIONS: General storage and movement of trays and pans.

CONSTRUCTION: Heavy duty, high tensile, extruded aluminum. Type 6063-T5 alloy.

UPPER FRAME & TOP: The upper frame is constructed of vertical uprights 1" x 2 1/2" x 1/8" thick extruded aluminum channel with top, cross and side bracing of 1 1/4" x 1 1/2" x 1/8" thick extruded aluminum channel, all fully welded together. A solid cap of .063" thick aluminum is welded to the uprights and cross bracing.

COMPOUND GUIDES: The compound guides are interlocking solid wall type, extruded aluminum panels. Each panel has a series of guides spaced at 1 1/2" on center, with 1/2" ledges and .090" wall thickness. The guides are welded to the vertical uprights.

REAR PANEL: The rear panel is .080" thick aluminum with a corrugation on each side for strength and enhanced air circulation. Panel is welded to the top, bottom and rear vertical uprights.

DOOR: The door consists of clear polycarbonate panel surrounded by a screw-together door frame. The door is supported by two heavy duty hinges designed to provide 270 degree door swing. An edge mounted magnetic door latch is provided to retain the door in a closed position.

The door is field reversible.

BOTTOM FRAME: The bottom frame is constructed of 1/8" thick aluminum sheet with four sides bent down 1 3/8", all corners welded smoothly. Tubular framework welded inside the 1/8" aluminum sheet for extra rigidity. Casters plates (2 3/4" x 4" x 3/8" thick pre-tapped) are welded to bottom of frame.

CASTERS: Four platform type 5" casters, full swivel design with sealed ball bearing axle and non-marking wheels.



Magnetic Door Latch



Heavy Duty Hinges

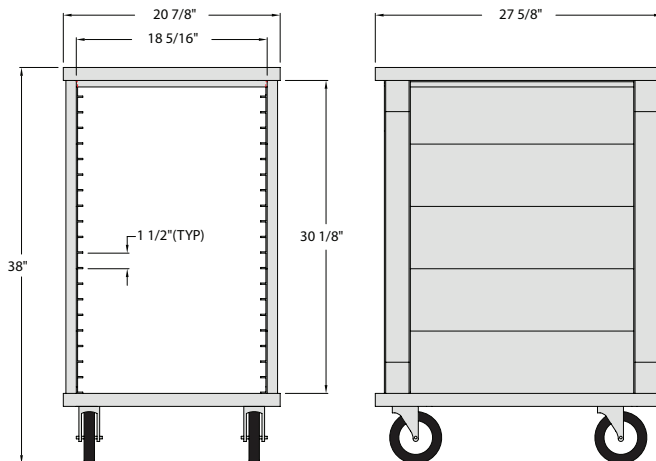

Model No.	Size W-H-D	Casters	Pan Cap.	H.D. Base	Ship Lbs.
1/2-Size Enclosed Pan Rack — 1 1/2" Runner Spacing					
50929	20 7/8" x 38" x 27 5/8"	5" (#C450)	20	No	105

Casters:

#C450 = 5" x 1 3/8" polyurethane platform type swivel caster.

Units hold 13" x 18", 14" x 18", and 18" x 26" pans by the lip.

This information is for general sales and engineering use only. New Age Industrial reserves the right to modify or make changes at any time without notice to materials and specifications.

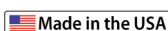

Distributed by: